

Kenics Static Mixer Installation, Operation and Maintenance Manual

Model:

KME-PVC & CPVC MIXERS

Unit Serial No.:

Equipment No.:

Manual No.:

804

For service and information contact:

Chemineer, Inc.

A Unit of Robbins & Myers, Inc.

Kenics Static Mixers
125 Flagship Drive
North Andover, MA 01845
Tel.: (978) 687-0101
Fax: (978) 687-8500
www.kenics.com





P. O. Box 1123
Dayton, Ohio 45401

INSTALLATION, OPERATION AND
MAINTENANCE MANUAL

KME-PVC & CPVC STYLE MIXERS

MANUAL NO. 804 REV. 1/1/82

CONTENTS	PAGE
GENERAL.....	1
OPERATION & MAINTENANCE.....	3
INSTALLATION, KME-PVC & CPVC.....	7
PARTS DRAWING, STYLE KME-PVC & CPVC	

FACTORY: Chemineer Kenics
North Andover, Mass. 01845
Refer to the front cover of this manual for the
name and address of your local Chemineer Kenics
representative.

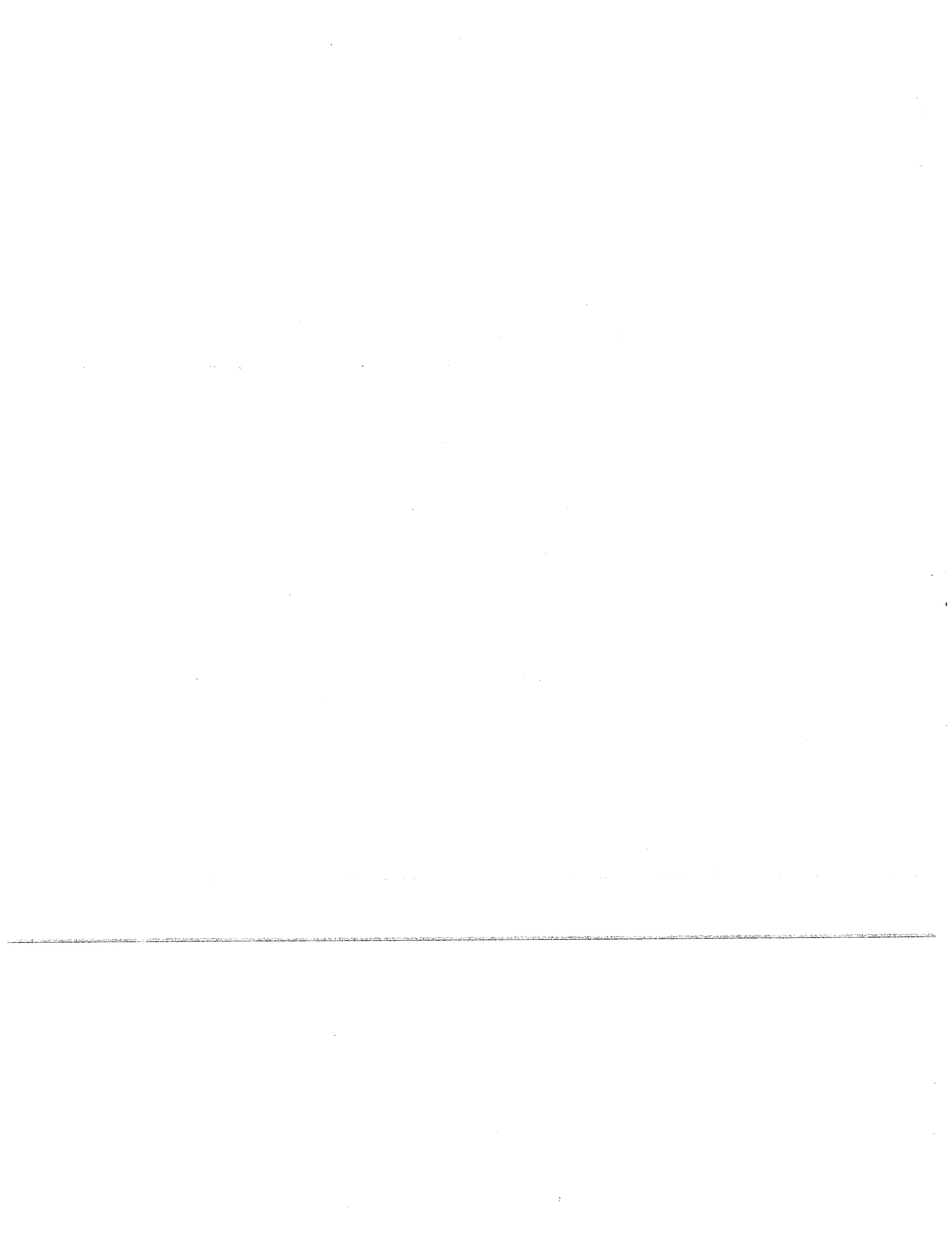

GENERAL: Your Kenics Mixer is a rugged piece of process mixing equipment manufactured to demanding design and quality standards. This manual has been provided to assist you in the storage, handling, installation and operation of your mixer and should be reviewed carefully before removing the mixer from the package. Adherence to a very few precautions will assure a highly satisfactory installation and years of trouble free service.

The few difficulties encountered with Kenics Mixers most often result from improper handling, installation, and operating procedures. The following quick check list should assist you in avoiding any difficulties:

1. Flanged mixers should not be bolted into systems where misalignment or gaps exist between the mixer and mating flanges. This can be especially critical to plastic (FRP, PVC, or CPVC) mixers. Follow flange tightening instructions later in the manual.
2. Plastic (FRP, PVC, CPVC) mixers must be handled and stored with care. Never use chains, cables, or fork lifts in direct contact with the mixer. If the mixer is too large or heavy to be moved manually, use a web sling or two heavy cloth straps spaced at least 1/2 the mixer length apart. Lifting lugs, if provided, should be used. Never drag or push the mixer; always lift it.
3. Mixers should be operated within process and pressure/temperature limits specified. Consult your local representative or the factory prior to changing operating conditions.
4. Injection of side streams prior to the mixer can be very important to operation of the mixer where large viscosity density, or volumetric differences exist. Refer to the Operation Section of this manual or consult your local representative or the factory for specific recommendations.
- ~~5. Some Kenics Mixers are equipped with loose, removable internal components as specified on the equipment order drawing. Extreme care should be exercised in handling and lifting in order to avoid damage and personal injury.~~

For dimensional and construction information refer to the PARTS DRAWING in this manual and to the equipment order drawing supplied with your mixer.

KENICS MIXER IOM MANUAL

GENERAL INSTRUCTIONS

REV. 1/1/82

INSPECTION AND/OR SHIPPING DAMAGE: Your Kenics Mixer was carefully packaged, crated, or protected for shipment. However, upon receipt it should be carefully inspected for any shipping damage. Any damage should be reported immediately and a claim filed with the responsible carrier. Your local Chemineer Kenics representative or the factory Customer Order Service Department can assist with claims.

Shipping package contents should be inspected for conformity with your order and for proper unit quantities. Any discrepancies should be reported to the factory Customer Order Service Department within one week of receipt.

STORAGE AND HANDLING: All Kenics Mixers should be stored indoors in clean, well ventilated storage areas. Care should be taken to see that excessive loads are not applied to the mixer during storage. Sealing surfaces (thread & flanges) should be protected. The original shipping container is adequate protection for most storage conditions. A rust-preventative paint is applied to carbon steel external surfaces prior to shipment. For extended storage in harsh environments additional coating or protection may be required.

Mixers must be handled with appropriate care. Careless handling may result in permanent damage.

FIELD MODIFICATION TO KENICS MIXERS: No field modifications (cutting to length, addition of fittings, etc.) to Kenics Mixers should be made without prior consultation with your local representative or the factory. Integrity of the mixing elements can be seriously altered without proper instructions.

OPERATION: There are few special operating instructions required with Kenics mixers. Your mixer was designed based upon the flow rate specified and most efficient performance will occur at that rate. The mixer, however, will accommodate wide flow variations in most processes. Consult your local representative or the factory for specific recommendations.

The nameplate on your mixer and the equipment order drawing include product pressure/temperature rating information. These ratings should not be exceeded. For service conditions other than the specified ratings, consult your local representative or the factory.

INJECTION AND METERING: Since the Kenics mixer is a radial mixer having characteristics approaching a plug flow device, a minimum amount of backmixing is achieved. In order to maintain this characteristic, excessive surging or pulsating of the feed components should be minimized to avoid nonuniformity of the final product. This can be especially important with certain applications including addition of a caustic or acid for pH control or blending of wide viscosity streams. It is therefore important that the upstream equipment including type of pump and injection method be considered when designing mixer systems.

PUMP SELECTION: For low viscosity systems (500 cps or less) with constant head, centrifugal pumps may be used. With fluctuating heads, a valving system to control flow is necessary to maintain proper on-stream metering. For high viscosity systems and/or high pressure operations, rotary positive displacement types such as gear pumps and screw pumps are recommended.

For reciprocating piston pumps (which have an inherent pulsating action) an accumulator should be installed before the flow discharge to the mixer in order to dampen the pulsating effect. High pulse rate or multihead types of pumps can also be used to maintain a steady discharge flow.

Refer to published industry standards and engineering guide lines for recommended practice relating to the design and selection of pumps and piping systems.

INJECTION METHODS

COMMON APPLICATIONS: Sidestream introduction normally does not require special consideration and can be simply accomplished by any convenient method including standard 'T' or 'Y' type connections. Most blending applications where three elements (Model 3) or more are utilized and dispersion applications where six elements (Model 6) or more are used do not require special sidestream introduction. For certain applications involving extreme volumetric ratios or widely differing viscosities, or where minimum models are used (Model 2 for blending or Model 4 for dispersion), injection can be more critical and the following configurations are recommended:

METHOD 1 - For liquid-liquid or gas - gas blending using a two element design (Model 2)

with volumetric ratios less than..... 100:1
 or viscosity ratios less than..... 1000:1
 or density ratios less than (liquids)..... 2:1
 or density ratios less than (gases) 5:1

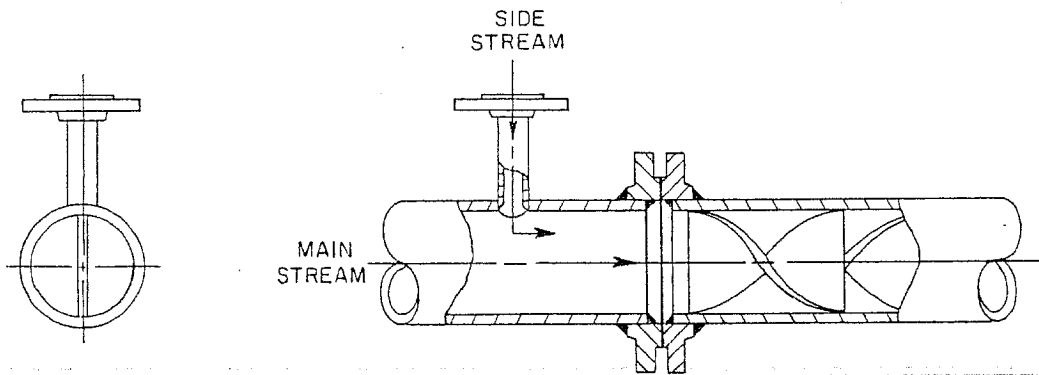

The sidestream introduction point should be as close as possible to the first element, usually no more than 1-2 pipe diameters upstream. Introduction should be in the center of the pipe and parallel to the leading edge of the first element as shown above. The sidestream velocity should be equal to approximately twice the mainstream velocity. Where the above component ratios are exceeded, for either blending or dispersion, Method 2 injection is preferred.

METHOD 2 - For liquid-liquid or gas - liquid dispersion using a four element design (Model 4)

or volumetric ratios greater than..... 100:1
 or viscosity ratios greater than..... 1000:1
 or density ratios greater than (liquids)..... 2:1

When any of the above design conditions exists, a true injector which crosses the pipe wall and approaches the centerline, as shown below, is preferred to the nozzle introduction under Method 1.

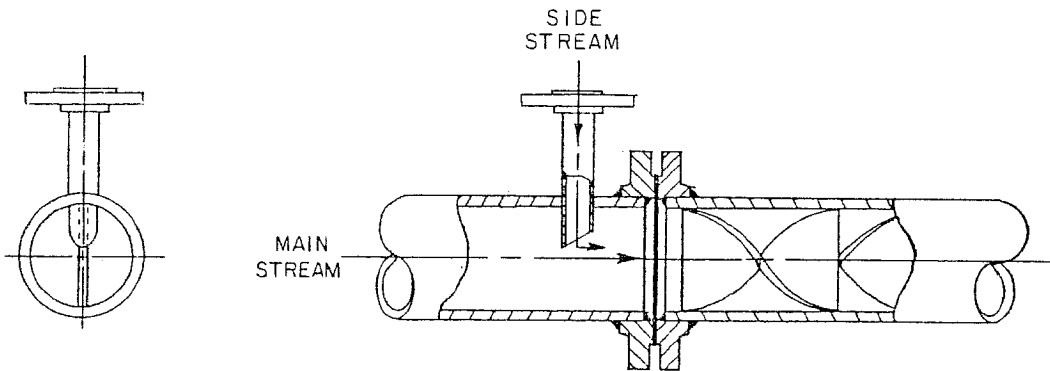

The smaller stream should be injected into the main flow. The injector tip of the minor component should be in the center of the pipe and as close to the leading edge of the first element as possible, ideally less than one pipe diameter. Injection should be parallel to the leading edge of the first element as shown above. The sidestream velocity should be approximately two times the mainstream velocity, regardless of component viscosities.

For viscosity ratios much greater than those shown, mixer performance can be effected by shear rate, absolute viscosity level, flow rates and non-Newtonian characteristics. Consult Chemineer Kenics for specific recommendations.

KENICS MIXER IOM MANUAL

GENERAL INSTRUCTIONS

REV. 1/1/82

MAINTENANCE: Kenics mixers require no routine maintenance other than sealing joint care typical to the rest of the piping system. For mixers with removable elements (KMR, KMR-PTFE and Sanitary) the element assembly may be removed for periodic cleaning or inspection by disconnecting the adjacent downstream component which must be as long as the mixer in order to extract the mixing element. Otherwise, both ends of the mixer must be disconnected and the mixer removed from the pipe line.

If the mixer supplied contains removable elements, note the warning below.

CAUTION

THIS EQUIPMENT CONTAINS REMOVABLE
INTERNAL COMPONENTS, HANDLE WITH
CARE TO PREVENT DAMAGE OR INJURY.

INSTALLATION, GENERAL: Kenics mixers can be located anywhere in your piping system and may be installed vertically, horizontally, or at any intermediate angle. The mixing action produced by the mixer continues for some distance downstream and it is desirable to leave considerable distance after the mixer to achieve maximum benefit. Where the mixer is used to achieve uniformity, such as in sampling, or prior to manifolds and where disengagement of phases can occur, the mixer should be located no more than 1-2 pipe diameters from the desired result.

KME-PVC & CPVC style mixers are designed for threaded, flanged, or solvent bonded installation in your piping system. Refer to your equipment order drawing for the specific end option hardware supplied.

Before installation, purge process lines to remove foreign material and debris. In most new construction or modifications to process piping there is a high probability of foreign material within the system, which if not removed could damage the mixer.

THREADED END MIXERS: Kenics mixers with threaded ends are provided with die cut NPT threads which are cut to high quality standards. Little difficulty should be encountered in achieving sound, leak free joints if good pipe fitting practice is followed and mating threads are of equal quality. A high quality thread sealing compound will help to assure leak free joints.

PLAIN END MIXERS: Style KME-PVC & CPVC mixers are also supplied as plain ended units for those customers who are skilled in solvent bonding and wish to apply their own end configuration.

FLANGED MIXERS: Flanged mixers should fit snugly into your piping system without gaps or misalignment at either end. It is poor practice to over tighten flange bolts in order to compensate for misalignment or gaps in the piping system. Flange distortion or housing to flange joint fracture may occur.

When connected to a flange face of another material, soft resilient full face flat gaskets (about 1/8" thick) that are compatible with the process fluid should be used. However, a wide variety of gasketing materials can be used depending upon plant standard, materials being handled, or gasket supplier recommendations. Local gasket distributors should be contacted for specific recommendations.

INSTALLATION INSTRUCTIONS
KME-PVC & CPVC STYLE MIXERS
MANUAL NO. 804 REV. 1/1/82

Recommended mounting hardware is a hex head bolt, hex-nut and two flat washers per bolt hole. Lubricate the bolt thread, the underside of the head, and both faces of each washer. Assemble all hardware finger tight.

Tighten the bolts in increments of 25 per cent of the recommended bolt torque as shown in the table below, loading all bolts at each increment before proceeding to the next increment. Use a criss-cross pattern as you would tighten the lug nuts of a tire.

RECOMMENDED BOLT TORQUE

Mixer Size	Bolt Dia. Inches	Torque ft/lbs	
		Min.	Max.
1, 1 1/2	1/2	10	15
2, 3, 4	5/8	20	30
6	3/4	33	50

When final torque value is reached follow a rotational pattern (clockwise) until all bolts are stable at final torque value. Two complete times around is usually sufficient.

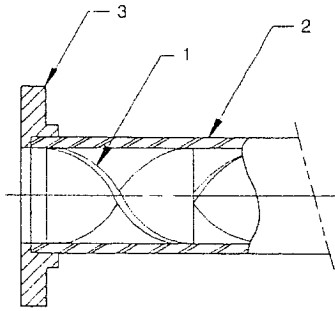

ITEM	DESCRIPTION	MAT'L
3	Flat Face Socket Flange (2)	[1]
w/FLAT FACE SOCKET FLANGE		

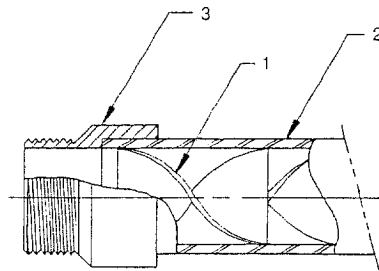

ITEM	DESCRIPTION	MAT'L
3	Threaded Coupling (2)	[1]
w/THREADED ENDS		

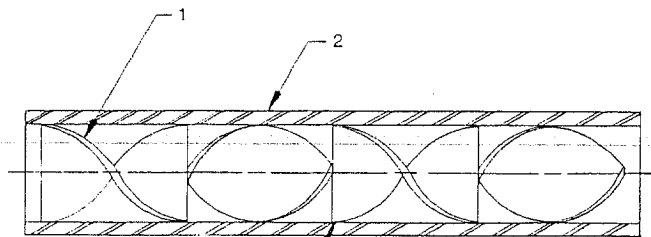

FULL LENGTH, INTEGRAL EDGE SEALED
ELEMENT/HOUSING BOND

ITEM	DESCRIPTION	MAT'L
1	Element Assembly	[1]
2	Housing (SCH80S)	[1]

BASE MIXER w/PLAIN ENDS [2]

NOTES: [1] Material is either PVC or CPVC. Refer to equipment order drawing for material supplied.

[2] Model 4 shown. Other models ranging from 2 to 24 elements available. Refer to equipment order drawing for model supplied.

