

Epsilon Pump



A range of highly engineered progressing cavity pumps offering lifetime cost savings compared to conventional drive train designs.

Typical Applications

- Primary and secondary sludge
- Mineral processing
- Industrial chemicals, detergents, polyethylene glycol
- Crude oil, hydraulic oil, waste oil
- Starches, liquefied potato peel, cocoa butter
- Natural and synthetic latex
- Mine dewatering
- Milk curds, sauces, fruit juices
- Paper stocks
- Gypsum and silicate
- Kaolin slurry, coating slurry

Capacity

- Up to 420 m³/h

Pressure

- Up to 24 bar

Temperature

- 10°C up to 110°C

Features and Benefits

Flexishaft™ Transmission

Wearing components are eliminated between the drive end and the pumping element, offering you increased reliability. No lubrication is needed, therefore product contamination is eliminated. A shorter Flexishaft™ is available where space is a priority. Backed by a 10-year warranty.

Bloc Construction

Minimizes overall dimensions, giving you a shorter pump length. Eliminates the need for coupling and guard.

Interchangeable Components

A large number of Epsilon components are interchangeable with the Compact C Pump, reducing inventory holding.

Materials of Construction

Available in cast iron or stainless steel, with a choice of rotor and stator materials to suit individual applications e.g. hard chrome plated rotor or natural rubber stator.

Inspection Cover

Available for applications where rag content is a problem.

Bloc Low Running Speeds

Reduced wear for a longer working pump life which extends the periods between routine maintenance. Think of the savings that could be realized on abrasive applications.

Gentle Pumping Action

Minimizes shear and crush damage to the pumped product, while maintaining a steady flow when pumping products with a high solids content.

Duracoat Coating

Rotors can be supplied with a range of specialized coatings to help extend the life of the rotors through improved wear and corrosion resistance.

High Pressure/Long Haul Pumping

Can offer considerable project cost savings by utilizing small borehole pipework and eliminating the need for a series of pumps when pumping over long distances or with high head requirements

Robust Drives

Specially selected fixed and variable speed drives for longer life.

Epsilon Pump

Performance

*E1BB models and above, and various 4 stage options are bareshaft and not available on a form folded baseplate.

For guidance in selecting a pump or for 4 stage and larger Epsilon models, please contact NOV.

Dimensions

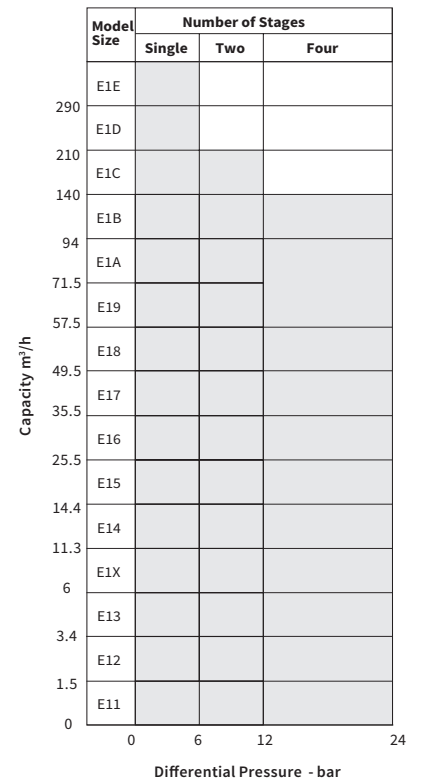
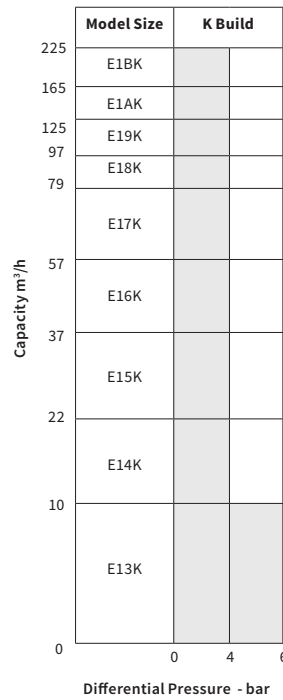
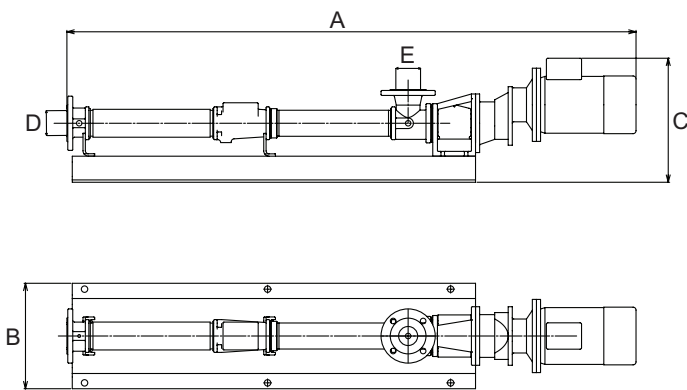

Standard Flexishaft				
Model	A	B	C	D & E
E1XA	50	12	12	2
E1XB	62	12	17	3
E14A	74	14	19	3
E14B	86	17	19	3
E14K	82	14	19	3
E15A	80	14	19	3
E15B	98	17	19	3
E15K	91	17	19	3
E16A	91	17	19	4
E16B	125	20	24	4
E16K	103	17	19	4
E17A	114	17	23	6
E17B	133	20	24	6
E17K	130	20	24	6
E18A	119	20	23	6
E18B	149	20	26	6
E18K	136	20	24	6
E19A	136	20	26	8
E19B	154	20	26	8
E19K	154	20	26	8
E1AA	145	25	26	8
E1AB	172	20	29	8
E1AK	166	20	26	8
E1BA	161	20	29	8
E1BK	183	20	29	8

Short Flexishaft				
Model	A	B	C	D & E
E14A	65	14	19	3
E14B	78	17	19	3
E14K	73	14	19	3
E15A	72	14	19	3
E15B	89	17	19	3
E15K	82	17	19	3
E16A	82	17	19	4
E16B	112	20	24	4
E16K	94	17	19	4
E17A	101	17	23	6
E17B	121	20	24	6
E17K	115	20	24	6
E18A	146	20	23	6
E18B	134	20	26	6
E18K	124	20	24	6
E19A	120	20	26	8
E19B	139	20	26	8
E19K	139	20	26	8
E1AA	129	25	26	8
E1AB	159	20	29	8
E1AK	150	20	26	8
E1BA	146	20	29	8
E1BK	170	20	29	8

Small Epsilon standard Flexishaft				
Model	A	B	C	D & E
E11B	45	12	12	1 1/4"
E11D	51	12	12	1 1/4"
E12A	45	12	12	1 1/4"
E12B	51	12	12	1 1/4"
E12D	66	12	12	1 1/2"
E13K	53	12	12	1 1/2"
E13A	47	12	12	1 1/2"
E13B	53	12	12	1 1/2"

All dimensions are in mm's and for guidance only. Flanges to ANSI B16.1, B16.5 and NPT pipe thread. For certified drawings or assistance in selecting a pump, please contact NOV.

