

# Multiplex Plunger Pumps

## Installation, Care and Operation Manual

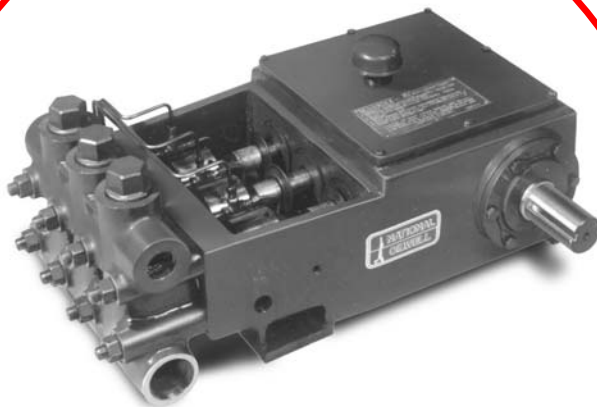

**30T-2**

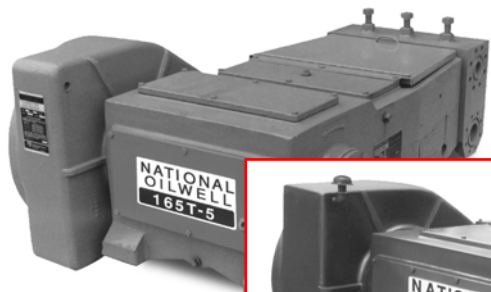

**165T-5**



**300Q-5**

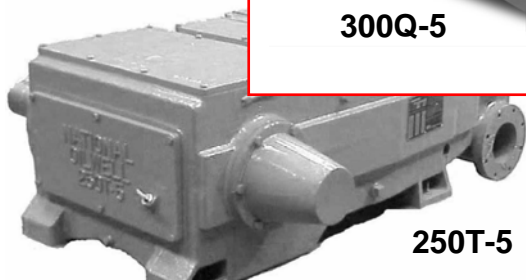

**250T-5**



**200T-5**

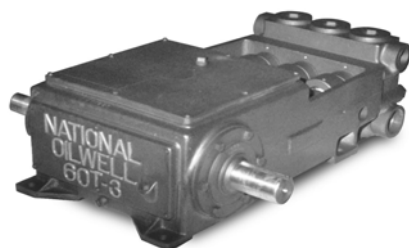

**60T-3**

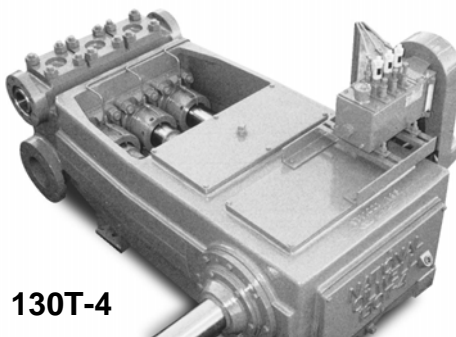

**130T-4**

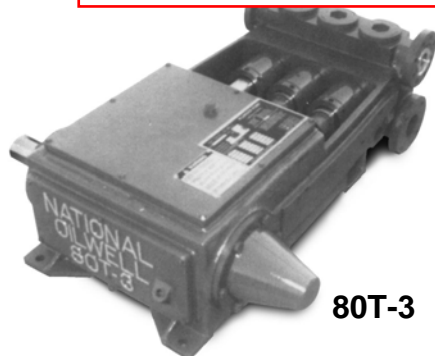

**80T-3**



**100T-4**

Covering the following pumps:

- 30T-2**
- 60T-3**
- 80T-3**
- 100T-4**
- 130T-4**
- 165T-5**
- 200T-5**
- 250T-5**
- 300Q-5**

### Sales / Technical Information

USA Tollfree: 1-800-324-4706  
Phone: 1 (918) 447-4600  
Fax: 1 (918) 447-4677  
Internet: <http://www.nov.com>



**NATIONAL OILWELL VARCO**

**SUPPLEMENT FOR  
ALL PUMP MANUALS**

**! WARNING !**

**PRESSURE**

**RELIEF**

**VALVES**

**! NOTICE !**

Our technical publications relative to reciprocating pumps state that pressure relief valves must be installed in the discharge systems from these units. This supplement is issued to emphasize the importance of relieving the discharge system of all pressure which exceeds the rated working pressure applied by the manufacturer to the specific pistons and liners (or plungers and packing) in any particular unit.



For the protection of persons and property the discharge system from each Reciprocating Pump must be equipped with a device which relieves the system of all pressures which exceed the pressure rating applied by the manufacturer to each particular piston or plunger diameter. Allowances will be made for pressure surges which are inherent with the reciprocating action of piston and plunger pumps. The percentage of pressure allowance appears later in this publication and in the "Standards of the Hydraulic Institute" (13<sup>th</sup> edition).

The relieving device must provide for instantaneous pressure relief, it may be a valve designed for automatic or manual resetting; however, if preferred, rupture discs or burst discs may be installed.

FAILURE to comply with the procedures outlined in the Warning may result in damage to the pump and related equipment and more importantly may cause serious bodily injury or death!

#### THE PRESSURE RELIEF VALVE:

1. This valve must be a full opening type.
2. It must have a working pressure rating, equal to or greater than, the maximum working pressure of the pump.
3. The through capacity of the valve, when fully opened, must be sufficient to relieve the full capacity of the pump without excessive overpressure.
3. The relief valve must be between the pump fluid end and any valve in the discharge system.
4. There must be no restricting device(s) between the relief valve and the pump fluid end.

#### RUPTURE DISC OR BURST DISC:

1. These discs must have a diameter which is not less than the pipe size of the pressure relief flange.
2. These discs must have a rupture or burst pressure rating consistent with the specifications tabulated later in this publication.
1. The relief valve discharge line should not terminate in the pump suction line.
2. The line should terminate in the supply tank, if possible.
3. The line must be securely anchored.
4. The line must be the same pipe size as, or may be larger than, the discharge connection on the relief valve.
5. If the line is of great length, this must be taken into consideration in sizing the relief valve.
6. There must be no restrictions or valves in the relief valve discharge line.

#### LOCATION OF THE RELIEF VALVE:

1. The relief valve must be placed in the discharge line as close as possible to the pump fluid end or it may be mounted on the pump discharge manifold.
2. The relief valve must be on the pump side of any discharge strainer.

NOTE: Follow the foregoing instructions if rupture discs or burst discs are installed.

#### SUGGESTED SET PRESSURES FOR THE PUMP RELIEF VALVES:

##### PUMP TYPE:

Double Acting – Duplex  
Double Acting – Triplex  
Double Acting – Quintuplex  
Single Acting – Triplex  
Single Acting – Simplex  
Single Acting – Duplex  
Single Acting – Triplex  
Single Acting – Quintuplex  
Single Acting – Septuplex

Note: The above set pressures are to be observed when installing rupture discs or burst discs.

##### OPERATING PUMP PRESSURE:

Piston Pressure Rating – Plus 25%  
Piston Pressure Rating – Plus 10%  
Piston Pressure Rating – Plus 10%  
Piston Pressure Rating – Plus 10%  
Plunger Pressure Rating – Plus 25%  
Plunger Pressure Rating – Plus 20%  
Plunger Pressure Rating – Plus 10%  
Plunger Pressure Rating – Plus 10%

## Foreword...

This manual is published as a guide for the normal operation of your **NATIONAL OILWELL VARCO** equipment. Because of the many factors which contribute to the function or malfunction of this machinery, and not having complete knowledge of each factor or combination of factors, we cannot detail all facets of this subject. We must therefore confine the scope of this presentation and when situations encountered are not fully encompassed by complete, understandable instructions, these situations must be referred to the manufacturer.

When other than routine servicing is necessary, it can be most efficiently performed if the unit is removed to an area of adequate space where an over-head crane, hydraulic lift, bearing pullers, impact tools, etc., are accessible.

The dimension and tolerances specified in this publication are those desirable for the most efficient operations of the equipment. When components become worn or when new parts are introduced into a worn unit, it may not be possible or economically feasible to reestablish such strict alignment and correct all dimensional deviations.

Improvements in design, engineering, materials, production methods, etc., may necessitate changes in these products and result in inconsistencies between the content of this publication and the physical equipment. We reserve the right to make these changes without incurring any liability or obligation beyond that which is stipulated in the purchase contract.

*The pictures, photographs, charts, diagrams, drawings, verbal contents and specifications are not to be construed as giving rise to any warranty on the part of NATIONAL OILWELL VARCO. National Oilwell Varco makes no warranty, either expressed or implied beyond that which is stipulated in the purchase contract.*

**NATIONAL OILWELL VARCO** pumps are manufactured by National Oilwell Varco at the McAlester, Oklahoma plant. The serial number, assigned each pump is stamped on the power end. Please refer to this serial number when ordering parts for the pump.

The right and left sides of the pump are determined by viewing the pump from the back of the power end, looking toward the fluid end. This position is also used to identify the plungers and their related parts as being number one, two and three, beginning at the left side of the pump.

## **! CAUTION ! CAUTION ! CAUTION !**

EXERCISE SAFETY IN ALL PERFORMANCES: DO NOT IGNORE ANY WARNINGS; USE ONLY APPROVED METHODS, MATERIALS AND TOOLS. DO NOT PERMIT ANY FUNCTION OF QUESTIONABLE SAFETY; ACCIDENTS ARE CAUSED BY UNSAFE ACTS AND UNSAFE CONDITIONS. SAFETY IS YOUR BUSINESS AND YOU ARE INVOLVED.

## **! WARNING ! WARNING ! WARNING !**

*BEFORE PERFORMING ANY SERVICE FUNCTION, BE CERTAIN THAT THE UNIT IS SEPARATED FROM ITS POWER SOURCE OR THAT THE POWER SOURCE IS LOCKED-OUT TO PREVENT ANY FORM OF ENERGY FROM ENTERING THE EQUIPMENT. THIS WOULD INCLUDE ELECTRICAL OR MECHANICAL ENERGY INTO OR FROM THE PRIME MOVER(S), PNEUMATIC ENERGY FROM THE COMPRESSOR/AIR SYSTEM, ETC.*

**! WARNING ! WARNING ! WARNING !**

FAILURE TO OBSERVE THE WARNINGS AND NOTES OF CAUTION IN THIS PUBLICATION CAN RESULT IN PROPERTY DAMAGE, SERIOUS BODILY INJURY, OR DEATH.

**! ATTENTION - NOTICE - IMPORTANT !**

THESE TERMS ARE USED TO DRAW ATTENTION TO ACTION THAT WILL CAUSE DAMAGE TO THE PUMP, COMPONENTS OR ATTACHMENTS.

**! ATTENTION !**

**PUMP NOMENCLATURE:**

ALL PUMP SIZES WITHIN THIS MANUAL WILL BE DESCRIBED WITH THE NEW OR CURRENT NOMENCLATURE. THE OLD 'J' MODEL PUMP NOMENCLATURES DESCRIBED ON THE FRONT COVER, BUT NOT INCLUDED IN THIS MANUAL EXCEPT AS NEEDED, ARE TO BE UNDERSTOOD AS BEING INCLUDED WITH THE NEW NOMENCLATURES.

**! WARNING ! WARNING ! WARNING !**

**BEFORE SERVICING PUMPS:**

1. SHUT DOWN OR DISENGAGE THE PUMP POWER SOURCE.
2. SHUT DOWN ALL PUMP ACCESSORY EQUIPMENT.
3. RELIEVE OR "BLEED OFF" ALL PRESSURE FROM THE PUMP FLUID CYLINDER(S).

FAILURE TO SHUT DOWN POWER AND RELIEVE PRESSURE FROM THE PUMP BEFORE SERVICING CAN RESULT IN SERIOUS PERSONAL INJURY AND PROPERTY DAMAGE.

**Plunger Pump Nomenclature Example....**

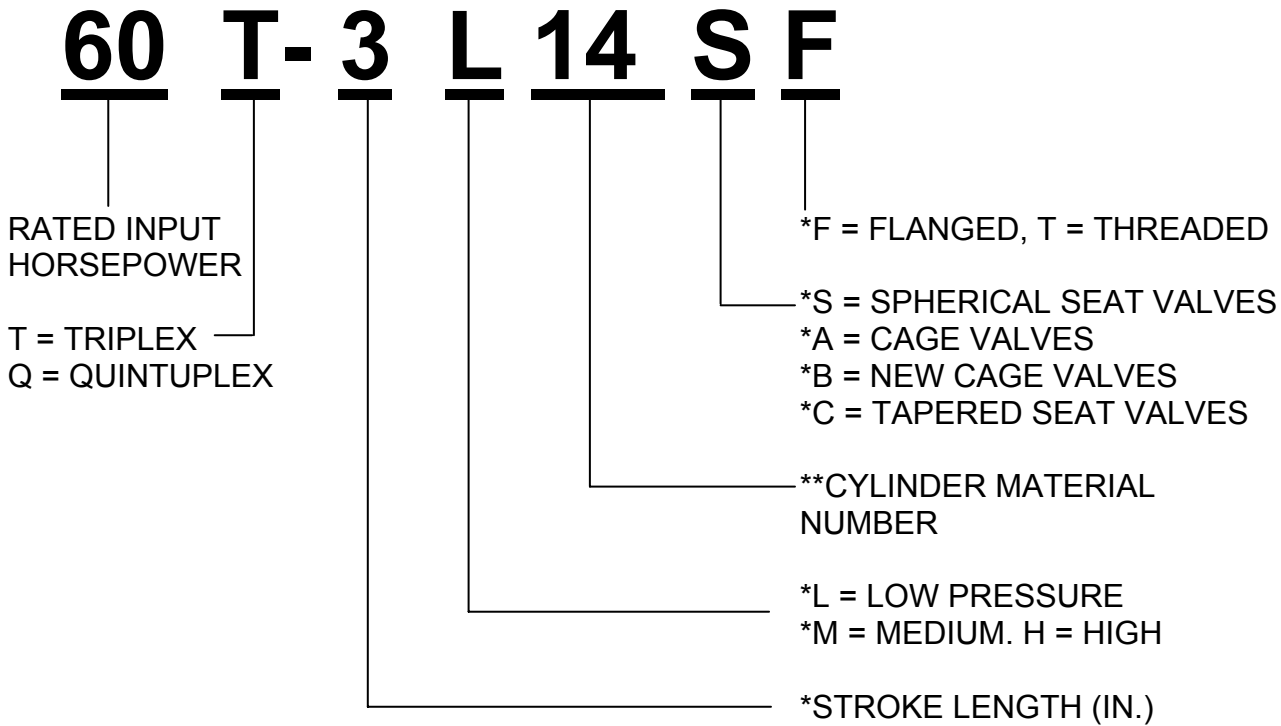

\*NOMENCLATURE MAY BE SHORTENED IN PARTS LISTS OR OTHER INSTANCES TO LEAVE OFF THE MATERIAL, VALVE TYPE, ETC. THIS FULL NOMENCLATURE DESCRIPTION IS GIVEN FOR INFORMATIONAL PURPOSES.

\*\*CYLINDER MATERIAL NUMBER EXAPLES INCLUDE:  
14 = 9D NICKEL ALUMINUM BRONZE  
12 = FORGED STEEL  
06 = 316 S.S.  
(Inquire about other material numbers)

## Table of Contents...

### INSTALLATION

	<u>PAGE</u>
<b>I. GENERAL</b>	
A. Suction Line .....	9
B. Discharge Line .....	9-10
C. Power End .....	10
D. Fluid End .....	10
E. Plunger Packing .....	11
F. Plunger Packing Lubrication .....	11
G. Suction Pulsation Dampener	
1. Low Pressure - Plastic Body .....	11
2. High Pressure - Aluminum Body .....	12

### LUBRICATION

<b>I. GENERAL</b>	
A. Oil .....	13

### OPERATION

<b>I. GENERAL</b>	
A. Operation Check List .....	14

### MAINTENANCE

<b>I. GENERAL</b>	
A. Daily Maintenance .....	15
B. Monthly Maintenance .....	15
C. Storage .....	16
D. Start-Up After Storage .....	16
<b>II. TROUBLE SHOOTING GUIDE .....</b>	<b>17-19</b>

### OVERHAUL AND REPAIR

<b>I. GENERAL</b>	
A. Tools Required .....	20
B. Check Points and Adjustments	
1. 30T, 60T, & 80T .....	20
2. 100T, 130T, 165T, 200T, 250T & 300Q .....	20-21

## Table of Contents (Continued)...

### DISASSEMBLY

	<u>PAGE</u>
<b>I. POWER END</b>	
A. Intermediate Rods and Oil Wiper Retainers .....	22
B. Crankshaft Assembly .....	22
J-30 & J-60 (Old Style) .....	22-23
30T, 60T, & 80T .....	23
J-100 & J-150 .....	23
100T, 130T, 165T, 200T, 250T & 300Q .....	24
C. Crankshaft Bearings (All Pumps) .....	24
<b>II. FLUID END</b>	
A. Fluid Cylinder Removal	
30T, 60T, & 80T .....	25
100T, 130T, J-150, 165T, 200T, 250T & 300Q .....	25
B. Stuffing Boxes and Plunger Removal	
30T, 60T, & 80T .....	25
100T, 130T, J-150, 165T, 200T, 250T & 300Q .....	26
C. Fluid End Valve Removal .....	26

### ASSEMBLY

<b>I. POWER END</b>	
A. Crankshaft Main Bearings	
30T, 60T, & 80T .....	27
100T, 130T, J-150, 165T, 200T, 250T & 300Q .....	28
B. Crankshaft and Center Support Bearings	
200T, 250T & 300Q .....	29
100T, 130T, 165T, 200T, 250T & 300Q .....	29
C. Connecting Rod and Crosshead Assembly .....	30
D. Connecting Rod to Crankshaft Assembly	
J-30 and J-60 (with Old Style straight cut connecting rods) .....	30
J-100, & J-150 (with Old Style straight cut connecting rods) .....	30
30T, 60T, 80T, 130T, 165T, 200T, 250T & 300Q (with New Style connecting rods) .....	31-32
E. Intermediate Rods and Oil Seal Retainers	
30T, 60T, 80T, 100T and 130T .....	32
100T, 130T, 165T, 200T, 250T & 300Q .....	32
All Pumps .....	33
<b>II. FLUID END</b>	
A. Stuffing Boxes and Plungers .....	33
30T, 60T, 80T .....	33-34
100T, 130T, 165T, 200T, 250T & 300Q .....	34
B. Fluid Cylinders (All Pumps) .....	35
C. Fluid Valves – Spherical, Tapered Seat Bottom Guided and Cage Type .....	35
D. Piping Installation .....	35
E. Plunger Packing Installation	
1. 850-N Packing .....	36
2. 1045 Packing .....	37
3. 699 Packing .....	38
4. Spring Loaded Kevlar Multiplex Packing .....	38-39



**Table of Contents (Continued)...**

**PLUNGER PUMP VALVES**

	<u>PAGE</u>
<b>I. OPERATIONAL MAINTENANCE</b>	
A. Suction and discharge .....	40
B. Valve Covers .....	40
C. Valve Cage and Cover Seals .....	40
D. Valve Springs .....	40
E. Valve Cages .....	41
F. Valve and Seat .....	41
<b>II. CAGE TYPE VALVES</b>	
A. Nomenclature .....	42
B. Valve Servicing Tools (charts).....	43
C. Disassembly Procedure.....	44-45
D. Valve Parts Inspection .....	46-49
E. Assembly Procedure.....	50-52
<b>III. TAPERED SEAT VALVES</b>	
A. Spherical Valves and Seats	
1. Valve Removal Procedure .....	53
2. Installation Procedure .....	53-55
B. Tapered Seat-Bottom Guided Valves	
1. Valve Removal Procedure .....	56
2. Installation Procedure .....	56-58

**GEAR REDUCER**

<b>I. LUBRICATION AND MAINTENANCE</b>	
A. General .....	59
1. Oil .....	59-60
2. Maintenance .....	60
<b>II. OVERHAUL AND REPAIR</b>	
A. General .....	61
1. Disassembly .....	61
2. Assembly .....	62-64
3. Installation .....	64

**P-55U LUBRICATOR**

<b>I. PUMP OPERATING INSTRUCTIONS</b>	
A. Operating Instructions .....	65
1. Box Suction Pumps .....	65
2. Flow Rate Adjustment .....	65
3. Sight Glass .....	65
4. Overfilling of Sight Glass .....	65
5. Reservoir Oil Level .....	65
6. Pump Displacement .....	65

**Table of Contents...**

**STORAGE OF PUMPS**

**PAGE**

**I. GENERAL**

A. General .....	66
B. Recommended Protection and Initial Storage .....	66
C. Six Month Servicing .....	67
D. Pre-Installation Check After Storage .....	67

<b>OWNERS RECORD .....</b>	<b>68</b>
----------------------------	-----------

<b>TYPICAL WATERFLOOD PUMP INSTALLATION SUCTION and DISCHARGE PIPING ARRANGEMENT .....</b>	<b>69</b>
--	-----------

<b>VISCOSITY EQUIVALENTS .....</b>	<b>70</b>
------------------------------------	-----------

## Installation...

### I. GENERAL

Careful planning of the plant layout will save considerable time and expense, both initially when the installation is made and later during the operation of the plant. In selecting the location for the pump, consideration should be given to the fact that a positive suction head at the pump inlet contributes toward the pump efficiency. However, the layouts of the piping, the arrangement of the fittings, and restrictions in the suction and discharge lines have even more effect. For this reason, all fittings and valves should be full opening; all bends should be of long radius or should be eliminated where possible. Long radius 45° ells should be used, particularly if installed near the fluid cylinder. The following points outline the basic requirements for an installation that will contribute greatly toward good pump operation.

#### A. SUCTION LINE

1. The suction line must not be smaller than the suction intake of the fluid cylinder and may be larger. The length of the suction line should be held to a minimum and should run straight from the supply tank to the pump.
2. When bends are required, they should be made with long radius 45° ells. Do not use a bend directly adjacent to the fluid cylinder. Avoid using any 90° bends if at all possible.
3. Provide a full opening gate valve in the suction line adjacent to the supply tank to permit the line to be drained when necessary. Do not use any type of restricting valve.
4. Do not use meters or other restrictions in the suction line. Eliminate any rise or summit in the suction line where air or vapor can collect.
5. Pulsation dampening devices are strongly recommended.
6. When necessary to manifold a number of pumps to a common suction, the diameter of the manifold and suction pipe leading from the supply tank must be such that it has a cross-sectional area equal to, or greater, than the area of the combined individual suction pipes.
7. When a charging or booster pump is used in the suction line, it must have a capacity equal to twice that of the pump output. This is necessary to provide a charging pump with an output great enough to meet the peak volume requirements of the plunger pump during the suction stroke and not act as a restriction in the line.
8. All piping, both suction and discharge must be solidly and independently supported. The first support must be as close to the pump as practical. This is necessary to prevent placing the pump in a strain and to keep any vibration in the system from acting directly on the pump.

#### B. DISCHARGE LINE

1. Use a pulsation dampener or a desurger in the discharge line. It should be placed in the line as near the fluid cylinder as possible and ahead of any bend in the line.
2. Do not reduce the size of the discharge line below that of the pump outlet until the line has passed through the desurger, and is away from the pump approximately 20 feet (6m).
3. Any bend in the discharge line should be made with a long radius 45° ell. Do not use a bend directly adjacent to the fluid cylinder, particularly a 90° bend.

## Installation...

### I. GENERAL

#### B. DISCHARGE LINE (Continued)...

4. A pressure relief valve should be installed in the discharge line. The relief valve should be set to operate at a pressure no greater than 25% above the maximum rated pressure for the plunger size being used. It should be installed in the line ahead of any valve and be piped so that any flow is returned to the supply tank rather than the suction line. This will prevent possible damage to the suction line and suction dampener.
5. A by-pass line should be installed to permit the pump to be started without load. This allows oil to circulate and reach all parts in the power end before they are loaded.

#### C. POWER END

1. The pump must be mounted level and should be grouted in and be free of strain. This applies to a skid-mounted pump or a pump mounted directly on a concrete base.
2. The sheave of a belt driven pump must be correctly aligned with the prime mover sheave. Care must be used to prevent over-tightening as this will shorten belt life, place the pump in a strain, and cause undue additional loads on the crankshaft and bearings. Sheave sizes should not be smaller than the minimum approved diameter.
3. When connecting a direct-driven pump, the shafts must be correctly aligned. Couplings should not be expected to compensate for avoidable misalignment. With Thomas Flexible Couplings, angular misalignment should not exceed one-half degree. Offset misalignment of the centerlines of the two shafts should not exceed .015" (.381 mm). Actually, misalignment should be as small as practical.
4. Provision should be made to stop the pump automatically in the event of supply fluid failure. A pump should not be run dry, as this causes wear on the packing.
5. Adequate plunger chamber drains have been provided in the pump and should not be plugged. Drain lines should never be reduced in size from the connection provided.
6. The pump has been drained of oil after testing at the factory and **MUST** be filled with the proper oil (see page 13) before starting. The rust inhibiting oil coating inside the power end need not be removed before filling; however, it is recommended that the power end be checked to make sure dirt or contamination has not entered during shipment.

#### D. FLUID END

1. The fluid cylinder is shipped assembled to the pump complete with valves and cover plates. The stuffing boxes, plungers, and related items have also been assembled and tested with the pump (unless otherwise specified) and require no further assembly. Before the pump is started, these parts should be checked for tightness as well as for possible damage during shipment.
2. Thoroughly clean the suction line piping before starting the pump. Weld spatter, slag, mill scale, etc., will damage a pump in a short time.

## Installation...

### I. GENERAL (Continued)...

#### E. PLUNGER PACKING

The recommended style of packing has been installed and run at the plant. It does, however, require further "setting up" as the pump is started and brought up to pressure. Refer to pages 36 through 39 for correct procedure for packing used.

#### F. PLUNGER PACKING LUBRICATION

1. Automatic packing lubricators are beneficial on all installations and are required on pumps operating at high pressure (1200 psi [85kg/cm<sup>2</sup>] and up) to obtain good packing life.
2. When an automatic lubricator is used in water and power oil service, use Rock Drill (Air Drill) oil of proper viscosity. For butane-propane service, use NATURAL castor oil. Set lubricator to feed 5 to 7 drops per minute.

#### G. SUCTION PULSATION DAMPENERS

##### 1. Low Pressure - Plastic Body

- a. Some National Oilwell Varco plunger pumps are equipped with suction pulsation dampeners. These dampeners do an excellent job when properly charged and should be kept filled during operation.



At suction pressures over 10 psi (.7kg/cm<sup>2</sup>), the dampener should be deflated prior to bleeding off the suction pressure to prevent damage to the diaphragm.

- b. The plastic dampener body has an instruction decal attached, which lists the following installation and charging procedures.



#### HANDLE WITH CARE.

This is a plastic part and can be broken.

- c. Tighten cap screws with 10 to 12ft-lbs. of torque.



Use thread sealing compound on check valve and tighten until snug.  
**OVERTIGHTENING WILL DAMAGE BODY.**

- d. With pump operating - Charge dampener until bottom of diaphragm is visible through sight glass. Proper charge is when bottom of diaphragm is between center and top of sight glass.

## Installation...

### I. GENERAL (Continued)...

### G. SUCTION PULSATION DAMPENERS (Continued)...

#### 2. High Pressure - Aluminum Body

- a. In pressures in excess of 20 psi (1.406 kg/cm<sup>2</sup>) and up to 70 psi (10.545 kg/cm<sup>2</sup>), it is necessary to use the National Oilwell Varco high pressure suction dampener.
- b. The high-pressure dampener is charged in a similar manner to the low-pressure plastic dampener, using air or nitrogen to charge the diaphragm and maintain its position in relation to the sight glass.
- c. The following procedures should be used to service this dampener:
  - (1) The dampener is fitted to an adapter that may be either welded into an existing line or be a part of a separate dampener housing. Place a gasket on each side of the diaphragm retaining plate and place on the adapter.
  - (2) The dampener spacer is then placed on top of the retainer plate with the grooved side up and the flat side against the retainer gasket.
  - (3) The diaphragm fits into the groove on the spacer with the curved portion of the diaphragm above the spacer.
  - (4) Apply a continuous 1/8" diameter bead of silicone rubber on the outer edge of the diaphragm after it has been positioned into the spacer. This silicone rubber (GE Silicone Rubber or Dow-Corning Silastic) is readily available at most hardware stores. Assemble the body cover within ten minutes after applying the silicone rubber.
  - (5) Fit the dampener cover over the diaphragm and assemble the capscrews. Tighten these capscrews evenly to approximate 80 ft-lbs. of torque.
  - (6) Install the sight glasses, one in each side of the cover. Be sure to seat the sight glass packing carefully into the groove on the cover, as this must be an airtight connection.
  - (7) The air check valve has a pipe thread and must be made up into the cover airtight. Use a good pipe thread sealant to promote sealing.

## Lubrication...

### I. GENERAL

NATIONAL OILWELL VARCO Plunger Pumps are "splash" lubricated. The main bearings receive oil through ports in the frame. Crankshaft bearings are fed by splash and at low speed through roll pins from the crosshead reservoir. Crossheads and crosshead pin bushings are fed through holes in the crossheads and crosshead reservoir. Intermediate rods are lubricated from the splash they receive from the crosshead. At speeds under 200 rpm, special auxiliary oil systems are required except on the 300Q Initial filling should be into the crosshead reservoir on top of the crossheads.

### A. OIL

Use "extreme pressure" gear oil. The chart below shows the recommended grades for various temperatures surrounding the pump.

U.S. UNITS OF MEASURE	
Temperature	AGMA Industrial EP Gear Oil
+50°F to +155°F	AGMA No. 6 EP or ASTM/ISO Grade No. 320 (viscosity 1335 to 1632 SSU 100°F)
+20°F to +100°F	AGMA No. 5 EP or ASTM/ISO Grade No. 220 (viscosity 918 to 1122 SSU 100°F)
-20°F to + 60°F	AGMA No. 2 EP or ASTM/ISO Grade No. 68 (viscosity 284 to 347 SSU 100°F)

Crankcase Capacity - U.S. Gallons:	30T - 1-1/2	100T - 5-1/2	200T - 8
	60T - 2	130T - 5-1/2	250T - 8
	80T - 2	165T - 8	300Q - 12

METRIC UNITS OF MEASURE	
Temperature	AGMA Industrial Gear Oil
+10°C to +68°C	AGMA No. 6 EP or ASTM/ISO Grade No. 320 (Viscosity 228-352 cSt at 37.8°C)
-7°C to +38°C	AGMA No. 5 EP or ASTM/ISO Grade No. 220 (Viscosity 198-242 cSt at 37.8°C)
-29°C to +16°C	AGMA No. 2 EP or ASTM/ISO Grade No. 68 (Viscosity 61-75 cSt at 37.8°C)

Crankcase Capacity - Liters:	30T - 5.7	100T - 20.8	200T - 30.3
	60T - 7.6	130T - 20.8	250T - 30.3
	80T - 7.6	165T - 30.3	300Q - 45.4

Oil must pour freely at minimum operating temperature. Change oil every six months or as frequently as operating conditions require to maintain a clean, sludge-free oil of proper viscosity.

## Operation...

### I. GENERAL



THE FOLLOWING POINTS SHOULD BE CHECKED FOR THE PREVENTION OF TROUBLE OR TO CORRECT TROUBLE THAT MAY ARISE.

### A. OPERATION CHECKLIST

1. Pump must be a set level for proper lubrication. If an auxiliary lubrication pump is used for slow speed operation, make sure it is connected and is operating properly.
2. Make sure pump is filled with clean oil of the proper viscosity (see above).
3. Do **not** over-speed the pump.
4. Do **not** use a smaller diameter sheave than is recommended for the pump.
5. Make sure all safety shutdown switches are operating properly.
6. Keep all suction and discharge line valves fully open.
7. If a bypass is used to regulate output, make sure it is set properly.
8. Make sure the pressure relief valve is set properly.
9. Do **not** exceed the pressure rating of the pump for the particular plunger size.
10. Make sure the suction line is tight as air entering the suction line will cause severe hammering and knocking of the pump.
11. Make sure plunger and intermediate rod connections are tight and locked.
12. Check the plunger packing for correct adjustment (see pages 36 to 39).
13. Check the suction and discharge dampeners for proper charge as this is very important for long dampener life and good pump operation.
14. Make sure the hex nuts holding the cylinder in place are tight.



## Maintenance...

### I. GENERAL

The following points are intended as a guide to be used in setting up a maintenance program. Good preventive maintenance will pay big dividends in the form of reliable service with a minimum of trouble.

#### A. DAILY MAINTENANCE

1. Check power end oil level daily by means of the dipstick in the rear cover. Do not attempt to check the oil with the pump running. Inspect the oil for dirt or contamination and change if necessary. An increase in oil level indicates fluid end leakage into power end. Change oil immediately and check intermediate rod wipers and surface smoothness of rod. Check for plunger packing leakage.
2. Lubricate plunger packing frequently. Packing life can be greatly increased by greasing every four (4) hours with a small amount of grease. Grease is not recommended at pressures above 1200 psi. Use an alternate packing lubricator to drip the proper oil of the plunger for lubrication. (See page 13 for further details).
3. Check lubricator for proper level and operation.
4. Check plunger packing for excessive leakage. Replace packing as required.
5. Check stuffing box adjusting nuts for tightness.
6. Drain plunger leakage sump tanks if required.
7. Flush plunger chamber drain lines with kerosene on power oil pumps and fresh water on salt pumps. This may be done weekly unless salt and paraffin accumulation is severe.
8. Make sure suction and discharge line valves are fully open.
9. Check for leakage between the fluid cylinder and frame or stuffing box to fluid cylinder packing if required.
10. Check all seals for leakage.
11. Check belts or clutch for slippage. If either condition exists, correct immediately.

#### B. MONTHLY MAINTENANCE

1. Drain and refill crankcase every six (6) months or as often as required to maintain a clean, sludge-free oil of the proper viscosity.
2. Clean crankcase air breather with a non-explosive solvent.
3. Check all studs, nuts and capscrews for tightness. Inspect gaskets for leaks; tighten or replace as required.
4. Clean pump. Good housekeeping is a prerequisite to good maintenance.

## Maintenance...

### I. GENERAL (Continued)...

#### C. STORAGE

If the pump is to be idle for longer than one (1) week, it should be prepared for storage as follows:

1. Drain and clean crankcase thoroughly. Leave drain open and install 90° elbow, pointing downward, to permit air circulation and prevent condensation build-up.
2. Coat all bearings, finished surfaces, and entire inside surface of crankcase with a rust inhibiting oil.
3. Remove plungers and packing, clean and coat with rust inhibiting oil.
4. Remove fluid cylinder valves allowing cylinder to be thoroughly cleaned and drained.
5. Coat entire cylinder, valves and parts, with a rust inhibiting oil.
6. Thoroughly inspect pump and rotate crankcase once each month. Re-coat with rust inhibiting oil where necessary.

#### D. START-UP AFTER STORAGE

Any pump that has been in storage, either after field use or as shipped from the plant, will need a thorough inspection to make sure it has not been damaged in any way and that all parts are properly in place.



FAILURE TO OBSERVE THE FOLLOWING POINTS CAN RESULT IN SERIOUS DAMAGE.

1. Remove all covers on both power end and fluid end; thoroughly clean and inspect all parts and finished surfaces.
2. Check all bearings to make sure they are clean and in good condition.
3. Make sure valves, plungers and packing are properly installed and in good condition.
4. Carefully tighten all bolts, nuts, studs and working connections.
5. Fill power end to the proper level with clean oil of the proper viscosity. Make sure oil is poured into the crosshead reservoir and is worked into all bearings.
6. Fill packing lubricator and pump lines full. Check by breaking connection at stuffing box, working lubricator plunger until oil appears.

## Maintenance (Continued)...

### II. TROUBLE SHOOTING GUIDE

PROBLEM	POSSIBLE CAUSE	CORRECTION
<b>KNOCKING OR POUNDING IN FLUID END AND PIPING</b>	SUCTION LINE RESTRICTED BY: (1, 2, 3, 4)	
	1. TRASH, SCALE BUILD UP, ETC.	LOCATE AND REMOVE
	2. PARTIALLY CLOSED VALVE IN SUCTION LINE	LOCATE AND CORRECT
	3. METERS, FILTERS, CHECK VALVES, NON-FULL-OPENING, CUT-OFF VALVE OR OTHER RESTRICTIONS.	RE-WORK SUCTION LINE TO ELIMINATE
	4. SHARP 90° BENDS OR 90° BLIND TEES.	RE-WORK SUCTION LINE TO ELIMINATE.
	AIR ENTERING SUCTION LINE THROUGH CUT-OFF VALVE	TIGHTEN OR REPACK VALVE STEM PACKING
	AIR ENTERING SUCTION LINE THROUGH LOOSE CONNECTION OR FAULTY PIPE	LOCATE AND CORRECT
	AIR OR VAPOR TRAPPED IN SUCTION LINE	LOCATE RISE OR TRAP AND CORRECT BY STRAIGHTENING LINE, PROVIDING ENOUGH SLOPE TO PERMIT ESCAPE AND PREVENT BUILD-UP
	LOW FLUID LEVEL	INCREASE SUPPLY AND INSTALL AUTOMATIC LOW LEVEL SHUT-DOWN SWITCH
	SUCTION DAMPENER NOT OPERATING	INSPECT AND REPAIR AS REQUIRED
	WORN VALVES	INSPECT AND REPAIR AS REQUIRED
	ENTRAINED GAS IN FLUID	PROVIDE GAS BOOT OR SCRUBBER FOR FLUID
	POOR INLET AND OUTLET ARRANGEMENT AT SUPPLY TANK	INLET TO BE AT TOP OF TANK AND BAFFLED TO BREAK-OUT GAS AND PREVENT CHANNELING. OUTLET TO BE 12" FROM BOTTOM OF TANK AND AS FAR FROM INLET AS POSSIBLE, NEVER CLOSER THAN 90°.
	LOOSE PACKING ADJUSTING NUT	TIGHTEN AND/OR REPLACE PACKING
	INADEQUATE SIZED SUCTION LINE	REPLACE WITH INDIVIDUAL SUCTION LINE OF NEXT SIZE LARGER THAN INLET PUMP
	LEAKAGE PRESSURE RELIEF VALVE THAT HAS BEEN PIPED BACK INTO SUCTION LINE	REPAIR VALVE AND RE-WORK PIPING TO RETURN TO SUPPLY TANK - NOT SUCTION LINE.
BY-PASS PIPED BACK TO SUCTION	REWORK TO RETURN BY-PASSED FLUID BACK TO SUPPLY TANK - NOT SUPPLY LINE	
BROKEN PLUNGER	INSPECT WHEN ROTATING PUMP BY HAND AND REPLACE AS REQUIRED	

## Maintenance...

### II. TROUBLE SHOOTING GUIDE (Continued)...

PROBLEM	POSSIBLE CAUSE	CORRECTION
<b>KNOCK IN POWER END</b>	VALVE WEAR OR DAMAGE	CHECK FLUID END FOR BAD VALVES
	WORN MAIN BEARINGS	REPLACE AS REQUIRED
	LOOSE PLUNGER - INTERMEDIATE ROD CROSSHEAD CONNECTION	INSPECT FOR DAMAGE - REPLACE AS REQUIRED AND TIGHTEN
	WORN CROSSHEAD PIN, OR CONNECTING ROD	LOCATE AND REPLACE AS REQUIRED
<b>RAPID VALVE WEAR OR FAILURE</b>	CORROSION	TREAT FLUID AS REQUIRED
	ABRASIVES IN FLUID	FILTER AS REQUIRED
	IMPROPER INSTALLATION	INSPECT AND INSTALL PER INSTRUCTION SHEET IN PACKING BOX
	IMPROPER LUBRICATION (EITHER INSUFFICIENT OR EXCESSIVE OR INCORRECT TYPE)	CHECK INSTRUCTIONS IN MANUAL AND CORRECT AS REQUIRED.
	LUBRICATOR NOT OPERATING	INSPECT AND CORRECT AS REQUIRED
	ADJUSTING NUT LOOSE	INSPECT AND REPACK PER INSTRUCTIONS
	SCALE OR BUILD UP ON PLUNGER	TREAT FLUID AS REQUIRED
<b>SHORT PACKING LIFE</b>	WORN OR PITTED PLUNGERS AND/OR STUFFING BOX	REPLACE AS REQUIRED
	ABRASIVES IN FLUID	FILTER AS REQUIRED
	PUMP OPERATED WITHOUT FLUID	CHECK SYSTEM FOR FAULTY LOW-LEVEL SHUT-DOWN CONTROLS OR CLOSED VALVES AND CORRECT AS REQUIRED.
	ABNORMALLY HIGH FLUID TEMPERATURES	CHECK WITH MANUFACTURER FOR RECOMMENDATIONS ON TYPE OF PACKING
	WRONG TYPE OF PACKING FOR PARTICULAR FLUID BEING HANDLED	CHECK WITH MANUFACTURER FOR RECOMMENDATIONS ON TYPE OF PACKING
	CAVITATION (KNOCKING AND POUNDING IN FLUID CYLINDER AND PIPING)	REFER TO CORRECTION OF "KNOCK IN POWER END" ABOVE

## Maintenance...

### II. TROUBLE SHOOTING GUIDE (Continued)...

PROBLEM	POSSIBLE CAUSE	CORRECTION
<b>BROKEN OR PITTED FROM IMPLOSIONS CAUSED BY IN EXCESSIVE GAS OR AIR ENTRAINED FLUID.</b>	PLUNGER CRACKED AT INSTALLATION.	INSTALL NEW PLUNGER USING CARE TO AVOID ANY SHARP BLOW OR FORCE ON PLUNGER.
	PLUNGER CRACKED FROM THERMAL SHOCK.	CHECK SYSTEM TO ELIMINATE ANY SHARP OR SUDDEN TEMPERATURE DIFFERENCES. TEMPERATURE EXTREMES ON THE PLUNGER CAN OCCUR FROM PACKING AS DISCUSSED UNDER "SHORT PACKING LIFE" PROBLEM PR FROM TEMPERATURE CHANGES IN THE FLUID ITSELF.
	PLUNGER PITTED FROM IMPLOSIONS CAUSED BNY EXCESSIVE GAS OR AIR ENTRAINED IN FLUID.	CHANGE SUCTION SYSTEM TO ELIMINATE OR CHECK WITH MANUF. REGARDING USE OF SPECIAL PACKING ARRANGEMENT.
<b>RAPID WEAR OF HARD-COATED PLUNGER</b>	PACKING FAILURE.	CHECK AND CORRECT PER RECOMMENDATIONS UNDER "SHORT PACKING LIFE" PROBLEM.
	PLUNGER NOT SUITABLE FOR PARTICULAR SERVICE.	CHECK WITH MANUF. FOR RECOMMENDATION.
<b>OIL SEAL LEAKS</b>	PLUNGER NOT SUITABLE FOR PARTICULAR SERVICE.	CHECK AND CORRECT AS REQUIRED.
	PUMP NOT LEVEL.	CHECK AND CORRECT AS REQUIRED.
	WORN, CORRODED, PITTED, OR OTHERWISE DAMAGED SEALING SURFACE.	CHECK AND CORRECT AS REQUIRED.
	WORN OR DAMAGED SEALS.	CHECK AND CORRECT AS REQUIRED.
	OIL LEVEL TOO HIGH.	CHECK AND CORRECT AS REQUIRED.

## Overhaul and Repair...

### I. GENERAL

The bearings and other working parts in the power end have been designed for continuous duty, and if properly lubricated, will provide years of trouble-free service. However, after the pump has been in service for a long period of time, the bearings and other working parts will gradually loosen, and if not corrected, will lead to more serious trouble. The time to overhaul the pump will vary, depending on the operating conditions, and is therefore a matter that must be left to the good judgment of the operator. Complete disassembly and assembly procedures are discussed in their respective sections.

### A. TOOLS REQUIRED

Most of the tools required to overhaul the pump will be found in an ordinary set of mechanics hand tools. The special tools and equipment required and not furnished with the pump include a torque wrench, bearing puller, and a valve servicing kit. Also, a hot oil bath capable of reaching a temperature of 300° F (149° C) will be needed.

### B. CHECK POINTS AND ADJUSTMENTS

#### 1. 30T, 60T & 80T:

The crankshaft main bearings are single row, shim adjusted, tapered roller bearings. They have been assembled and adjusted at the factory with proper clearance and will give long trouble-free service. The proper clearance is found by adjusting the amount of shims until the crankshaft has .003" to .005" endplay and will rotate freely.

#### 2. 100T, 130T, 165T, 200T, 250T & 300Q:

- a. The crankshaft main bearings are non-adjustable, double row tapered roller bearings, factory set for the proper running clearance.
- b. The connecting rods, or bearing inserts, are solid aluminum alloy precision ground with the following tolerances -- page 21.
- c. The minimum allowable clearance between the crosshead and crosshead bore is .012" (.305 mm). The maximum allowable clearance, including wear, is .030" (.762 mm). This is for all pumps.
- d. Maximum allowable clearances between the crosshead pin and connecting rod bushings are listed on page 21. The bushings are pressed into the connecting rod and must be reamed to size. The pin and bushings must then be "blued" to check the fit. High spots in the bushings must be scraped.

## Overhaul and Repair...

### I. GENERAL

### B. CHECK POINTS AND ADJUSTMENTS (Continued)...

PUMP	CRANKSHAFT O.D.		MAXIMUM CLEARANCE		MINIMUM CLEARANCE	
	in	mm	in	mm	in	mm
30T	<u>2.500</u> 2.499	<u>63.500</u> 63.475	.012	.305	.003	.076
60T 80T	<u>3.250</u> 3.249	<u>82.550</u> 82.525	.013	.330	.003	.076
100T 130T	<u>4.125</u> 4.124	<u>104.775</u> 104.750	.018	.457	.007	.178
165T 250T 200T 300Q	<u>5.000</u> 4.999	<u>127.000</u> 126.975	.020	.508	.0064	.163

PUMP	CROSSHEAD PIN O.D.		MAXIMUM CLEARANCE		MINIMUM CLEARANCE	
	in	mm	in	mm	in	mm
30T	<u>1.3765</u> 1.3760	<u>34.963</u> 34.950	.007	.178	.001	.025
60T 80T	<u>1.8765</u> 1.8760	<u>47.663</u> 47.650	.007	.178	.0015	.038
100T 130T	<u>2.5635</u> 2.5300	<u>65.113</u> 65.100	.007	.178	.0015	.038
165T 200T 250T 300Q	<u>3.0015</u> 3.0010	<u>76.238</u> 76.225	.008	.203	.002	.051

## Disassembly...

### I. POWER END

It is not necessary to remove the fluid end when disassembling the power end. The plungers may be disconnected from the intermediate rods and left in the stuffing boxes.

#### A. INTERMEDIATE RODS AND OIL WIPER RETAINERS (ALL PUMPS)

1. Loosen the plunger lock screws (if used), disconnect the plunger from the intermediate rod, and remove the baffle plate.



A BACK-UP WRENCH MUST BE USED FOR REMOVAL OF PLUNGER AND INTERMEDIATE ROD TO PREVENT DAMAGE TO THE CONNECTING ROD.

2. The oil wiper retainer is piloted into the frame and held in place by two capscrews or a metal clip.
3. Remove the intermediate rod to crosshead lock screw (if used), and using a **back-up wrench** on the crosshead, unscrew the rod. Remove the rod and oil wiper retainer as one assembly.

#### B. CRANKSHAFT ASSEMBLY

- J-30 Prior to S/N 3854
- J-60 Prior to S/N 7476

1. Remove connecting rod bolts and cap.

**NOTE:** Match marks and deep halves together.

2. Connecting rod and crosshead must be moved all the way forward to clear crankshaft.
3. Remove crankshaft bearing retainers and seals, and shims. These shims should be tied together and marked for reassembly at their original location.



## Disassembly...

### I. POWER END

### B. CRANKSHAFT ASSEMBLY (Continued)...

## **! ATTENTION !**

COVER KEYWAYS TO PROTECT OIL SEALS DURING REMOVAL.

4. Rotate No. 1 throw to front, support the crankshaft, and remove it from either side, tapping it out with a brass bar to prevent damage to the end. This will automatically remove one of the main bearing outer races. The other race may be removed by knocking it out with a brass bar. Tag the outer bearing races so they may be reassembled with the same bearing cone and roller assembly.

#### **• 30T, 60T, and 80T**

1. Remove connecting rod bearing cup and both inserts.

**NOTE:** Match marks on rod and cap and keep halves of inserts together.

2. Connecting rod and crosshead can be removed through cradle chamber without disturbing the crankshaft. Interference with plungers and stuffing box nuts is possible depending on plunger size. Remove plungers if necessary.
3. Remove crankshaft bearing oil seal retainers and gasket.
4. Use puller screws in crankshaft bearing cage "back-out" holes, if necessary, and remove crankshaft assembly with main bearing cage from the left side of the pump. During removal have No.1 throw on crankshaft forward.

#### **• J-100 Prior to S/N 9568 and J-150**

1. Remove all the connecting rod bearing caps and both inserts. Keep halves inserted together.
2. Connecting rod and crosshead must be moved all the way forward with intermediate rods removed, to clear crankshaft.
3. Remove crankshaft bearing oil seals retainers and gasket.
4. Use puller screws in crankshaft bearing cage "back-outs" holes, if necessary, and remove crankshaft assembly with main bearing cage from the left side of the pump. During removal have No.1 throw on crankshaft forward.

## Disassembly...

### I. POWER END

### B. CRANKSHAFT ASSEMBLY (Continued)...

#### • 100T, 130T, 165T, 200T, 250T and 300Q

1. Remove connecting rod bearing cap and both inserts. Keep halves of inserts together.
2. Connecting rod and crosshead can be removed through cradle chamber without disturbing the crankshaft. Interference with plungers and stuffing boxes is possible depending on plunger size. Remove stuffing boxes if necessary.
3. Remove oil wiper troughs. (200T, 250T and 300Q)
4. Remove right hand bearing retainer and gasket.
5. Remove left hand bearing retainer and gasket and remove capscrews from bearing cage.
6. Crankshaft can be removed from left side of pump only. Puller holes are provided in the bearing cage if needed. Extreme care should be used in removing the crankshaft so as not to damage the center support bearings or the bearing journals on the crankshaft of the 300Q.

### C. CRANKSHAFT BEARINGS - ALL PUMPS

The crankshaft main bearings may be inspected while on the crankshaft and should not be removed unless necessary. A puller is required when replacement is necessary.

**NOTE:** Keep the component parts of the bearings together if they are to be re-installed. They are match marked and must be correctly assembled as a unit.

## Disassembly (Continued)...

### II. FLUID END

#### A. FLUID CYLINDER REMOVAL

##### • 30T, 60T and 80T

1. Disconnect piping.
2. Remove the eight (8) fluid cylinder hex nuts and slide cylinder forward over the main frame studs.

##### • 100T, 130T, 165T, 200T, 250T and 300Q

1. Fluid cylinders can be removed without disturbing the stuffing boxes or plungers. But it is recommended that the stuffing boxes and plungers be removed for easier access to the lower cylinder studs and nuts.
2. Disconnect piping.
3. Remove nuts holding stuffing box retainer in place.
4. Slide retainer clear of the cylinder studs.
5. Remove fluid cylinder retaining socket head capscrews.

#### B. STUFFING BOXES AND PLUNGER REMOVAL

##### • 30T, 60T and 80T

1. Rotate crankshaft until the intermediate rod is in the back position of its stroke. Loosen the plunger lock screw (if used), and disconnect the plunger from the intermediate rod.

## **! ATTENTION !**

USE BACK-UP WRENCH ON THE CROSSHEAD TO PREVENT DAMAGE TO CONNECTING ROD.

2. Slide the plunger forward in the stuffing box. Unscrew the intermediate rod. Remove the clip holding the intermediate rod wiper retainer; remove the rod and retainer as one assembly.
3. The plunger can now be slid back out of the stuffing box and removed through the cradle chamber.
4. Remove stuffing box nut and packing.
5. For removal of the stuffing box, the fluid cylinder must be first removed.

## Disassembly...

### II. FLUID END

#### B. STUFFING BOXES AND PLUNGER REMOVAL (Continued)...

##### • 100T, 130T, 165T, 200T, 250T and 300Q

1. Rotate the crankshaft until the intermediate rod is all the way forward (at the end of the discharge stroke). Remove the intermediate rod to crosshead lock screw, remove the plunger clamp assembly, and brake the intermediate rod loose from the crosshead one-fourth (1/4) turn.

## **! ATTENTION !**

A BACK-UP WRENCH MUST BE USED ON THE CROSSHEAD.

2. With the intermediate rod in the forward position, slide the plunger forward in the stuffing box.
3. Rotate the crankshaft until the intermediate rod is in the back position of its stroke. Unscrew at the intermediate rod and the intermediate rod wiper retainer capscrews then remove the rod and retainer as one assembly.
4. The plunger can now be slid back out of the stuffing box and removed through the cradle chamber.
5. Remove the stuffing box nut, lube fitting (copper tubing if lubricator is used), and packing.

#### C. FLUID END VALVE REMOVAL

Refer to valve section located in the middle of this manual.

## Assembly...

### I. POWER END

#### A. CRANKSHAFT AND MAIN BEARINGS

##### • 30T, 60T, and 80T

1. Thoroughly clean and remove all burrs from the I.D. of the cone and roller assembly and from the bearing seating surfaces on the crankshaft.
2. Heat the cone and roller assembly in an electric oven or oil bath to 300°F (149°C). It is recommended that a thermometer be used to prevent overheating.
3. After the bearings have been brought up to temperature and with the crankshaft firmly supported, install the cone and roller assemblies on the crankshaft. The large O.D. must go on first and be positioned next to the shoulder on the crankshaft. *Make sure the cone and roller assemblies are firmly against the shoulders on the crankshaft.*
4. Allow the crankshaft and bearing assembly to cool before installing in the power end.
5. Make sure the main bearing openings in the frame are clean and free of burrs.

**NOTE:** The crossheads and connecting rods on old J-30 pumps prior to S/N 3854 and J-60 pumps prior to S/N 7476 must be installed prior to replacing the crankshaft assembly.

6. With the cone and roller assemblies of the main bearings in place on the crankshaft, slide the crankshaft from either side through the main bearing openings in the power end frame with No. 1 throw forward.
7. Install the crankshaft main bearing outer races or cups; the thin edge of the tapered race leading into the bore over the cone and roller assembly.
8. Place the crankcase main bearing shims, amounting to approximately .050" (1.27 mm) in thickness, on either crankshaft bearing retainer. *If the old bearings and retainers are being re-installed, use the same amount of shims as before.*

**NOTE:** The following steps (9, 10a and 10b) are necessary only if new bearings are being installed. When the same crankshaft main bearings are being reassembled, use the same amount of shims as were previously used and use the steps as a check for adjustment.

9. Assemble the crankshaft bearing retainer and shims (less oil seal) to the main frame and tighten in place with the proper capscrews.
10. Install the other crankshaft bearing retainer (less oil seal) in the same manner as in step nine (9) above. To determine the correct amount of shims when installing new bearings, the following steps are recommended.
  - a. When first installing shims, use only enough shims to produce a slight drag when the crankshaft is rotated. Tap shaft on each end sufficient to insure that the bearing outer race is tightly against the retainer.
  - b. Then add enough shims to remove the slight drag or pre-load (approximately .005" [.127 mm] to .007" [.178 mm]), depending on the amount of pre-load). *The bearings are correctly adjusted when there is .003" to .005" end-play of the crankshaft and the crankshaft will rotate freely. Do not pre-load bearings.*

## Assembly...

### I. POWER END

#### A. CRANKSHAFT AND MAIN BEARINGS (Continued)...

##### • 100T, 130T, 165T, 200T, 250T and 300Q

The crankshaft should be clean and free of burrs. The cone and roller assemblies are to be heated in an electric oven or oil bath to 300°F (149°C). The use of a thermometer is recommended. *Bearing parts are match marked and should be noted prior to heating. Make sure parts are not interchanged.*

#### 1. Right Hand Bearing (Short Shaft Extension):

- a. Install chain sprocket on 165T.
- b. With a bearing cone and roller assembly at proper temperature, install on the crankshaft with the thick edge of the taper against the shoulder.
- c. Assemble the bearing spacer and outer race on the crankshaft and against the inboard cone and roller.
- d. Install outboard cone and roller assembly; thin edge against the bearing spacer.
- e. Tighten the lock nut and lock with lock washer prong. (This can best be done after the shaft is in the pump). *Make sure cone and roller assemblies are tight against the bearing spacer.*

#### 2. Left Hand Bearing (Long Shaft Extension):

- a. With bearing cone and roller at proper temperature, install on the crankshaft with the thick edge of the taper against the shoulder.
- b. Assemble the bearing spacer against the inboard cone and roller.
- c. Drive outer race into the bearing cage against bottom shoulder.
- d. Install the outer race and cage assembly and gasket against inboard cone and roller.
- e. Install outer cone and roller assembly; thin edge against the bearing spacer.
- f. Assemble lock nuts and lock washer.
- g. Tighten lock nut and lock with prong of lock washer. *Make sure cone and roller assemblies are tight against the bearing spacer.*

## Assembly...

### I. POWER END (Continued)...

### B. CRANKSHAFT AND CENTER SUPPORT ROLLER BEARING ASSEMBLY

#### • 200T, 250T and 300Q

1. Check the crankshaft bearing surfaces for nicks or burrs and remove.
2. Install snap ring in groove nearest left hand bearing cage.
3. Heat inner race of roller bearing to not more than 300°F (149°C) in electric oven or oil bath and install against snap ring.
4. Install second snap ring on first bearing.
5. Install snap rings in the frame bearing support areas. Install rings in inner grooves.
6. Install snap rings in the frame bearing support areas. Install rings in inner grooves.
7. Roller bearing assembly is a possible light press fit into the frame bore. Slide or gently tap the bearing assemblies into place against the snap rings.
8. Install outer snap rings.

#### • 100T, 130T, 165T, 200T, 250T and 300Q

1. Install the crankshaft assembly in pump locating the crankshaft bearing cage at the left side with the "TOP" mark up and the plastic gasket in its proper location. Use care when passing the bearing inner race through the first roller assembly.

**NOTE:** The crossheads and connecting rods on the old J-100 pumps prior to S/N 9568 must be installed prior to replacing the crankshaft assembly.

2. Check Timken locknuts and lockwashers and tighten securely.
3. Install right hand bearing retainer and gasket. Make certain "TOP" mark is facing upwards. Check clearance of Labyrinth seal to shaft. There should **not** be any metal-to-metal contact.
4. Install left hand bearing retainer and gasket as described previously.

**NOTE:** If pump is to have a gear reducer, it is necessary to replace the left hand bearing retainer with a retainer that has a double drain back area in the labyrinth seal area. Do **not** use dirt excluder inside the gear reducer.

5. Install dirt excluder tightly against each bearing retainer -- except as noted above.

## Assembly...

### I. POWER END (Continued)...

#### C. CONNECTING ROD AND CROSSHEAD ASSEMBLY (ALL PUMPS)

1. Press the crosshead pin bushing into the connecting rod.
2. Ream bushing to size (refer to page 21 for dimensions). Blue with pin and scrape bushing to remove high spots. (If service bushings are used, reaming will not be necessary in most cases).
3. Install the crosshead pin by pressing into crosshead or to facilitate assembly, the crosshead may be heated to no more than 300° F (149°C) in an electric oven or bath.

NOTE: Crossheads are marked "TOP" on extension rod end. Connecting rods and bearing caps are match marked as units. Install connecting rod in crosshead so match marks on top of crosshead correspond.

#### D. CONNECTING ROD TO CRANKSHAFT ASSEMBLY

##### • J-30 and J-60 (With Old-Style Straight-Cut Aluminum Connecting Rods)

1. Thoroughly clean and remove all burrs and nicks from connecting rod and crankshaft journals.
2. The connecting rod journals are a precision fit and require no adjustment. Make sure the match marks on connecting rod and cap are the same and on the same side.
3. Install connecting rod bolts and lock-type nuts. Use torque wrench and tighten to torque specified in chart below.

##### • J-100 and J-150 (With Old-Style Straight-Cut Connecting Rods)

The connecting rod bearings are precise fitting inserts requiring no adjustment. When reinstalling the same inserts, assemble them in pairs at their original location. Make sure the match marks on connecting rod and cap are the same and on the same side.

1. Install rod half of bearing, seat connecting rod on the shaft and install bolts.
2. Install other half of bearing and bearing cap, making sure dowel pins in the bearings are properly joined. Using a torque wrench, tighten to the torque specified in the chart below.

TORQUE: FT-LBS				
PUMP	30T	60T 80T	100T 130T	165T, 200T, 250T, 300Q
Straight, Cut Rod w/ Bolts & Locknuts	20	45	85	--
Straight, Cut Rod w/ Capscrews	--	--	150	--
Slant Cut Rod w/ Capscrews	30	75	150	250



**Assembly...**

**I. POWER END**

**D. CONNECTING ROD TO CRANKSHAFT ASSEMBLY (Continued)...**

**• 30T, 60T, 80T, 130T (New Style), 165T, 200T, 250T and 300Q**

*The connecting rod bearings are precision fitting inserts requiring no adjustment. When re-installing the same inserts, assemble them in pairs at their original location. Make sure the match marks on the connecting rod and cap are the same on the corresponding sides.*

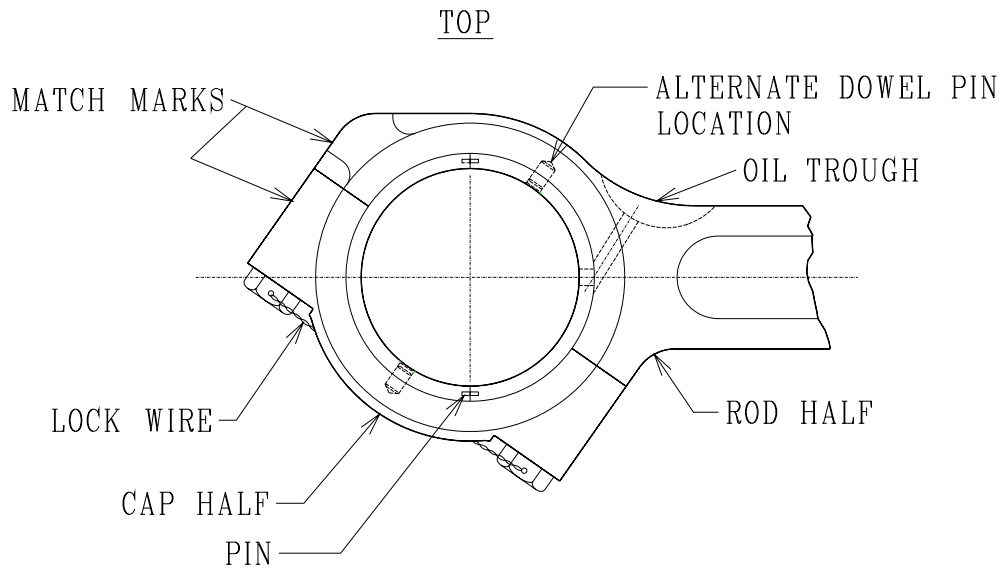

**Figure 1**

**NOTE:** It is possible to install these bearing shells incorrectly. Please follow instructions carefully.

## Assembly...

### I. POWER END

#### D. CONNECTING ROD TO CRANKSHAFT ASSEMBLY

##### • 30T, 60T, 80T, 130T (New Style), 165T, 200T, 250T and 300Q (Continued)...

1. Check bearing halves for pin engagement and fit over the dowel pin in the cap half of the connecting rod. Please note the drawing and match marks.
2. Install both bearing halves on the crankshaft with the dowel pins engaged as shown. Position crankshaft throw to the rear.
3. With bearing shells in position (as shown in drawing, pg. 31), fit the cap half of the connecting rod over the bearing shells. Make certain the dowel pin is seated properly and the lubrication hole in the bearing is toward the front so as to match the oil hole in the connecting rod.

**NOTE:** Later model connecting rods have the dowel pin located in the rod half. With this pin, the location of the rod is positioned first on the bearing shell.

4. Slide the connecting rod back over the crankshaft throw using caution so the outer surface of the aluminum insert is not damaged. Note the match numbers of the cap and rod to be certain the rod is assembled correctly.
5. Install the two (2) capscrews and torque as shown in chart. Lockwire the capscrews securely.

#### E. INTERMEDIATE RODS AND OIL SEAL RETAINERS

##### • 30T, 60T, 80T, 100T, and 130T

*Install two oil wipers; lips facing the power end. Open one from the power end side and one from the fluid side. On the power end side the wiper O.D. should be flushed with the face of the retainer. On the fluid end side, the wiper should be pressed in the retainer until it contacts the shoulder in the middle of the retainer. Install the third wiper on the fluid end side of the retainer with lip facing the fluid end.*

**NOTE:** Make sure O.D. wiper and I.D. of retainer are clean and dry before installation of the wiper.

##### • 100T, 130T, 165T, 200T, 250T and 300Q

Install two (2) oil wipers, lips facing the power end, and two (2) oil wipers with lips facing the fluid end. The inner wipers should shoulder against the raised area in the center of the retainer. Make certain the retainer and wipers are clean and dry before installation. An oily or greasy surface can cause the wipers to become loose.

## Assembly...

### I. POWER END

#### E. INTERMEDIATE RODS AND OIL SEAL RETAINERS (Continued)...

##### • ALL PUMPS

Rotate the crankshaft until the crosshead is all the way forward and install the retainer and rod as a unit.

**NOTE:** Make sure retainer gasket is in place prior to installation. Tighten rod and the crosshead using a **back-up wrench** on the crosshead to the following torques:

Threads	30T	60T 80T	100T 130T	165T, 200T, 250T & 300Q
Dry (ft-lbs)	175	200	400	480
Lubricated (ft-lbs)	150	150	325	385

### II. FLUID END

#### A. STUFFING BOXES AND PLUNGERS

Plungers are available in ceramic or steel.

## ! ATTENTION !

NATIONAL OILWELL VARCO DOES **NOT** RECOMMEND THE USE OF CERAMIC PLUNGERS FOR PUMPING FLAMMABLE LIQUIDS.

##### • 30T, 60T, and 80T

1. Thoroughly clean and remove any nicks or burrs from all mating surfaces of the main frame, fluid cylinder and stuffing boxes.
2. Insert stuffing boxes into main frame.

**NOTE:** The stuffing box is a press fit in the main frame and will have to be driven into position.

## ! ATTENTION !

PREVENT DAMAGE BY PLACING A BLOCK OF WOOD OVER THE STUFFING BOX FACE.

## Assembly...

### II. FLUID END

#### A. STUFFING BOXES AND PLUNGERS

##### • 30T, 60T, and 80T (Continued)...

**NOTE:** Stuffing box flange face should extend .001" to .004" (.025 mm to .102 mm) beyond the frame face to assure proper crush on the stuffing box seal. If this condition does **not** exist, premature gasket failure will occur!

3. Insert seals (stuffing box to fluid cylinder) into grooves in the face of the stuffing boxes. Grease lightly to hold in place until fluid cylinder is installed.
4. Assemble packing in stuffing box bore as per instructions included with each set of packing, or as described on pages 36 to 39.

##### • 100T, 130T, 165T, 200T, 250T and 300Q

1. Rotate crankshaft until the intermediate rod is at the end of the suction stroke.
2. With the stuffing box packing and plunger installed, slide the assembly into the pilot bore. If properly aligned and lubricated, the stuffing box will slide easily into place. When a flanged retainer is used with the stuffing box, make certain the lubrication fitting hole is at the top.
3. Tighten stuffing box hex nuts to the following torque values:

Threads	100T, 130T	165T, 200T, 250T & 300Q
Dry (ft-lbs)	400	800
Lubricated (ft-lbs)	325	640

4. Install rubber baffle (if used) on intermediate rod and connect plunger to intermediate rod with threaded connection or clamped connection. Make sure the mating surfaces are clean and free from nicks and burrs.

Tighten plunger rod using the following torques (threaded plungers):

Threads	100T, 130T	165T, 200T, 250T & 300Q
Dry (ft-lbs)	400	480
Lubricated (ft-lbs)	325	385

Tighten capscrew in plunger clamp assembly as follows (clamped plungers):

PUMPS:	100T, 130T	165T, 200T, 250T & 300Q
Maximum Torque Value	15 ft.-lbs.	15 ft.-lbs. (21) 3/8" 1-bolt clamp 30 ft.-lbs. (45) 1/2" 2-bolt clamp

5. Adjust stuffing box nut. (Adjusting nut should be tightened with the bar furnished with the pump). See instructions on pages 36 through 39 for proper packing procedure and lubrication practices.

## Assembly...

### II. FLUID END (Continued)...

#### B. FLUID CYLINDER (ALL PUMPS)

1. Install fluid cylinder, check stuffing box seals as cylinder is moved into place.
2. Tighten nuts alternately, pulling fluid cylinder up evenly; torque nuts to the following values:

THREADS	30T	60T 80T	100T 130T	165T, 200T, 250T & 300Q
Dry (ft-lbs)	300	500	400	800
Lubricated (ft-lbs)	240	450	325	640

3. When installing the suction discharge piping, always use the capscrews furnished with the pump as they are special high-strength and double heat-treated.

#### C. FLUID VALVES – SPHERICAL, TAPERED SEAT BOTTOM GUIDED AND CAGE TYPE (ALL PUMPS)

See Valve section of this manual.

#### D. PIPING INSTALLATION (ALL PUMPS)

1. Install flanges on fluid cylinder with special high carbon double heat-treated capscrews furnished with the pump.
2. Install suction and discharge lines to flanges.

## Assembly...

### II. FLUID END (Continued)...

#### E. PLUNGER PACKING INSTALLATION

##### 1. 850-N Packing

It is important that the following procedure be observed when replacing old packing to prevent rapid packing wear:

- a. Remove front crosshead reservoir cover plate and rotate pump to bring the desired plunger to the forward position.
- b. Back off locking set screw (if used) at intermediate rod crosshead connection and intermediate rod plunger connection. Using back-up wrenches, loosen connection one-fourth (1/4) turn.
- c. Rotate crankshaft until plunger is all the way back. Unscrew plunger or remove clamp assembly and slide plunger forward.
- d. Remove intermediate rod and intermediate rod seal retainer from as one assembly.
- e. Remove plunger and old packing, making sure stuffing box is clean. Plungers and boxes may be removed as an assembly by rotating the pump so the intermediate rod is all the way back, thereby disconnecting the plunger and sliding the stuffing box back and out.
- f. Oil each ring with light oil (**DO NOT GREASE**), and install packing per sketch included with the packing. Make sure the lips on the sealing rings face pressure shown.
- g. Install gland and pull down hand tight against packing.
- h. Install plungers, then pull adjusting nut down as tight as possible with bar furnished with the pump. **DO NOT USE A CHEATER!!**
- i. Install intermediate rod and retainer. Connect plunger and torque properly as outlined on page 34 & 35.
- j. For 850-N packing, start pump and operate under pressure; retighten adjusting nut. After pump has been running for two (2) or three (3) hours under pressure, packing will seat itself and the adjusting nut should be tightened as much as possible to eliminate any movement of the packing in the stuffing box. Use the bar furnished with the pump. **Do not use a cheater!**
- k. The adjusting nuts should be checked and each tightened for the first 2 or 3 days until the packing is completely seated and the adjusting nuts cannot be tightened any further. Use the bar furnished with the pump. **Do not use a cheater!**

## Assembly...

### II. FLUID END

#### E. PLUNGER PACKING INSTALLATION (Continued)...

##### 2. 1045 PACKING (also called No. 265)

*It is important that the following procedure be observed when replacing old packing to prevent rapid packing wear:*

- a. Remove crosshead reservoir and rotate crankshaft to bring plunger forward.
- b. Back off locking set screw (if used) at intermediate rod crosshead connection and intermediate rod plunger connection. Using back-up wrench, loosen this connection one-fourth (1/4) turn.
- c. Rotate crankshaft until plunger is all the way back, unscrew plunger or remove clamp assemblies and slide plunger forward.
- d. Remove intermediate rod and intermediate rod seal retainer from pump as one assembly.
- e. Remove plunger and old packing, making sure stuffing box is clean. Plungers and boxes may be removed as an assembly by rotating the pump so the intermediate rod is all the way back, disconnecting the plunger and sliding the stuffing box back and out.
- f. Starting with the first Phenolic ring, seat each ring individually in the order packaged. Eliminate the No. 1 Phenolic ring when using a sleeve washer with ceramic plungers.
- g. Install plunger and make-up the adjusting nut tight to insure the entire packing set is properly seated. The nut should be loosened and adjusting hand tight.
- h. Install intermediate rod and retainer. Connect plunger and torque properly as outlined on page 34 & 35.
- i. Start the pump and run with normal system pressure. Tighten the adjusting nut, carefully watching for excessive heat build-up. Continue to tighten the nut until it is a good, snug fit and the nut shows no movement in the threads.

## ! IMPORTANT !

IF THE ADJUSTING NUT LOCKS AND CANNOT BE MOVED, IMMEDIATELY REMOVE THE PRESSURE FROM THE PUMP, BACK OFF THE NUT ONE-HALF (1/2) TURN, AND START AGAIN.

- j. This packing may or may not leak, depending on the circumstances, and it does not require continuous adjustment. It should be checked and re-tightened the first day or two after installation of new packing, but should require very little attention after this.
- k. This packing can be used on hard coated or ceramic plungers without lubrication, but as with any packing, extended life is possible through the use of lubrication. When using a mechanical or drip type lubrication system in water service, use rock Drill (Air Drill) Oil of the proper viscosity. Drip five to seven drops per minute.

## Assembly...

### II. FLUID END (Continued)...

#### E. PLUNGER PACKING INSTALLATION

##### 3. 699 PACKING

For top performance from the soft packing of "Teflon" fiber read and carry out the following instructions. Use the above method to remove and re-install intermediate rod and plunger.

- a. Packing may be butt or diagonal cut. Stagger joints in successive rings at least 90°.
- b. Slide rings into stuffing box, but do **not** tap or drive rings into place. Tests have shown that this method gets maximum performance from soft packing of "Teflon" fiber.
- c. Tighten stuffing box nut finger tight and start pump. Packing should be leaking, if not, loosen stuffing box nut. Remember, install this soft packing with a minimum of gland pressure to minimize friction and heat build-up.
- d. Reduce leakage to desired level by tightening stuffing box nut about 1/6 turn at a time every few minutes.
- e. If gland heats up to a temperature that will boil water, back-off stuffing box nut and repeat run-in until temperature remains after nuts are re-tightened.

***"Teflon" is DuPont's register trademark for TFE- Fluorocarbon fiber.***

##### 4. SPRING LOADED KEVLAR MULTIPLEX PACKING

*- Recommended Packing Procedure -*

- a. Before re-packing, determine cause of failure.
- b. Remove plunger, stuffing box nut, and all internal parts in stuffing box. Remove stuffing box itself if necessary to clean.
- c. Clean all parts and determine if parts are worn or reusable. Replace all worn parts.
- d. Soak new packing elements in oil. Lubricate all other parts.
- e. Note the depth of stuffing box bore. If greater than four inches (4"), install appropriate spacer. See appropriate parts-list for applicable spacer.
- f. Install parts into stuffing box in the following order: spacer (if needed), spring, follower (small end first), Kevlar ring and brass ring (with care), (alternate these items three (3) times, twice for 30T), and then add the bushing (gland ring).
- g. Screw on the nut -- hand tight.
- h. Insert plunger into packing assembly.



## Assembly...

### II. FLUID END

#### E. PLUNGER PACKING INSTALLATION

##### 4. SPRING LOADED KEVLAR MULTIPLEX PACKING (Continued)...

- i. Tighten packing nut. Bushing should seat and shoulder against stuffing box face. Back off the nut one-half turn.
- j. If stuffing box has been removed, re-install assembly onto multiplex.
- k. Connect plunger to intermediate rod and tighten.
- l. Insert stop pin into stuffing box nut.
- m. Fill lubricator with rock Drill Oil for normal temperature, steam cylinder oil for high temperature fluids. Fill lubricator lines by pumping it manually. Check its operation.
- n. Start pump at slow speed and low pressure if possible, tighten stuffing box nut and insert stop pin in hole. Watch for a short period of time. Oil if needed.
- o. Set lubricator to twice normal rate. After 24 hours, resume normal operation. Check stuffing box for excessively high temperatures and abnormal leakage.

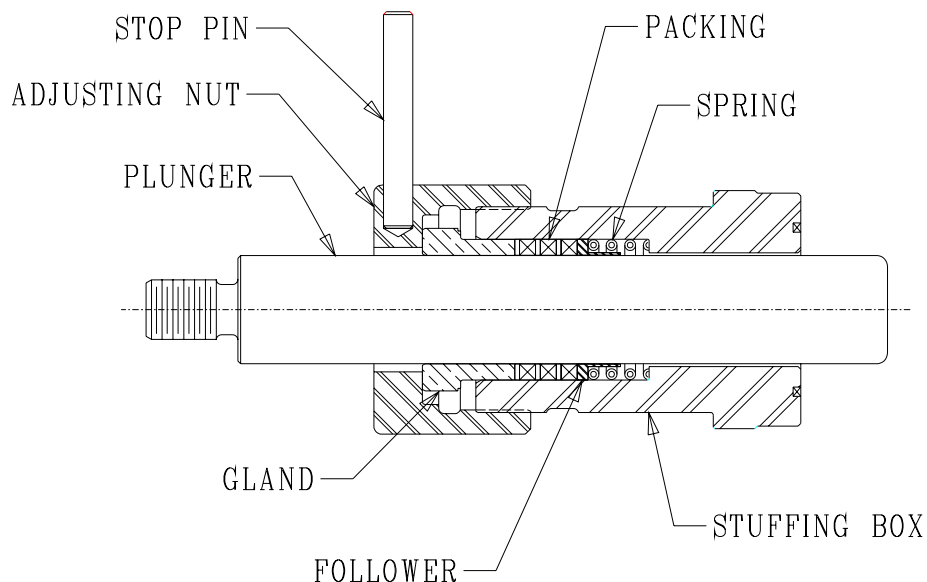

**Figure 2**

## Plunger Pump Valves...

### I. OPERATIONAL MAINTENANCE

#### A. SUCTION AND DISCHARGE

As with any plunger pump, the necessity for having an adequate suction head and proper piping design of both suction and discharge cannot be over emphasized.

## ! ATTENTION !

NOISY VALVES, DUE TO IMPROPER FILLING, CAN LEAD TO SHORT LIFE AND RAPID MECHANICAL WEAR OF THE POWER END PARTS.

#### B. VALVE COVERS



THE VALVE COVERS, AS USED WITH THE NATIONAL OILWELL VARCO PLUNGER PUMPS, **MUST** BE KEPT TIGHT AT ALL TIMES. DUE TO THE DISCHARGE PRESSURE APPLYING A CONSTANT LOAD TO THE COVERS, IT IS **NOT** POSSIBLE TO CHECK THEIR TIGHTNESS WITH THE PUMP RUNNING OR WITH PRESSURE IN THE CYLINDER.

Bleed off the discharge pressure and check the tightness of the covers as outlined under the assembly procedure for the type of cover used.

#### C. VALVE CAGE AND COVER SEALS

##### 1. Cage Type Valves

There are three identical seals in each valve stack. The seals perform a very important function in this design valve and we recommend that they be changed any time they are removed from the pump.

##### 2. Cover Seals

The cover seals should be replaced as required.

#### D. VALVE SPRINGS

The springs used with the NATIONAL OILWELL VARCO valves are made of inconel alloy or stainless steel.

## ! ATTENTION !

THESE SPRINGS SHOULD BE CHANGED APPROXIMATELY ONCE A YEAR IN ORDER TO ASSURE PROPER VALVE ACTION AND ELIMINATE THE POSSIBILITY OF A SPRING BREAK.

## Plunger Pump Valves...

### I. OPERATIONAL MAINTENANCE (Continued)...

#### E. VALVE CAGES

The cages are normally made from aluminum, bronze, stainless steel or hardened steel, depending on the type of service. These cages are precision machined to give long, continuous service.

#### F. VALVE AND SEAT

##### 1. Cage Type Valves:

There are four basic valve and seat assemblies available, depending on the type of service. They are the disc type, the ball type, the wing-guided type, and the spherical type. These valves can be made available in a variety of materials on special order.

##### 2. Tapered Seat Valves:

There are two basic OEM valve & seat assemblies available, depending on the type of service. They are the bottom guided (BG) tapered seat valves and the spherical tapered seat valves. The BG valve and seat are available in a variety of materials depending on the type of fluid being pumped. The spherical valves are made of Nitronic 50 material.

## Plunger Pump Valves (Continued)...

### II. CAGE TYPE VALVES

The NATIONAL OILWELL VARCO cage type valve is a patented design valve. This manual will assist in performing the normal maintenance requirements of the valves.

#### A. NOMENCLATURE

1. Acme threaded valve cover with center bolt. (One piece solid cover used on 30T, 60T or 80T).
2. Retainer (not used on 30T, 60T or 80T).
3. Cover and Cage Seal, Suction or Discharge (interchangeable).
4. Disc Valve Cage, Suction or Discharge (interchangeable).
5. Valve Spring, Suction or Discharge (interchangeable).
6. Stop, Valve Disc, 30° Taper Cut in Cage, not used in Ball Valve Cages.
7. Valve Disc, Valve suction or Discharge (interchangeable).
8. Valve Seat, Discharge only - Small bore (I.D.) used to retain Suction Spring.
9. Valve Seat, Suction Only - Large Bore (I.D.) same as Suction Throat Bore.
10. Valve Seat Suction and Discharge (interchangeable).

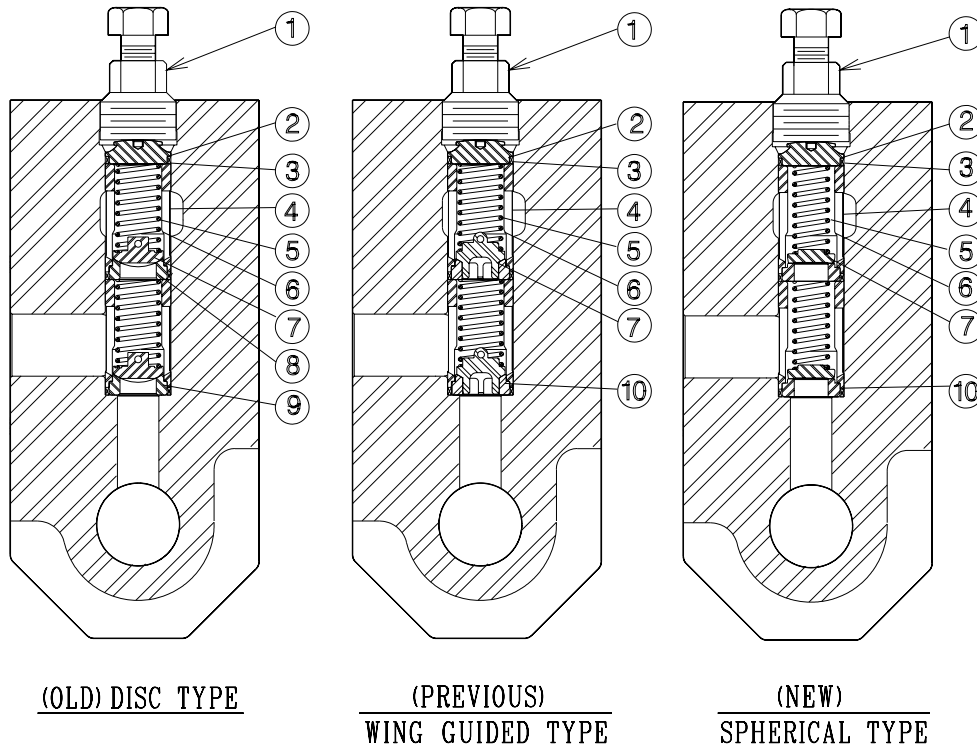

Figure 3

## Plunger Pump Valves...

### II. CAGE TYPE VALVES (Continued)...

#### B. VALVE SERVICING TOOLS (charts)

The valve servicing tools referred to on the following pages are listed below:

**CAGE TYPE VALVES  
(SPHERICAL, BOTTOM GUIDED, BALL, & DISC)**

Pump Size	Valve Kit	Cage Puller	Cage Bumper	Seat Drive	Magnet Retriever
30T-2H, 60T-3H, 80T-3H	1710292	1710249	1790080	1790040	1790034
30T-2L, 60T-3M, 80T-3M, 100T-4H, 130T-4H	1711251	1711249	1790080	1790041	1790034
100T-4M, 130T-4H, 130T-4M, 165T-5H, 165T-5HA, 200T-5H, 200T-5HA, 250T-5H, 250T-5HA	1712342	1712242	1790080	1790042	1790034
165T-5M, 200T-5M, 250T-5M, 300Q-5M	1713068	1713069	1790085	1790043	1790034
375T-7H	1715338	1715339	1790085	1790053 G-1790062 G-1715342	1790034
165T-5HB, 200T-5HB, 250T-5HB, 300Q-5H	1713351	1713352	1790085	G-1790064	1790034

## Plunger Pump Valves...

### II. CAGE TYPE VALVES (Continued)...

#### C. DISASSEMBLY PROCEDURE

1. Remove threaded cover. (The covers should be tight enough to require an extension on a 24" pipe wrench to loosen). Inspect threads for wear, which could occur if cover was loose.
2. Remove retainer with hook on a magnetic retriever. Some retainers are tapped with a lifting thread for removal.
3. Remove cover seal from top of cage with hook on magnetic retriever. (This hook is rough ground at the plant and should be finished to a flat sharp edge to be most effective). (Figure 4, page 45).
4. Before removing spring, observe amount of pre-load. Spring should extend about 1/8" to 3/16" above the top of the cage. It is not recommended that you stretch a spring to secure the correct pre-load as this causes physical damage to the spring. This should be done only on these cases where a new spring is not available. Remove the spring with hook. (Figure 6, page 45).
5. Remove cage with puller as illustrated. Under normal conditions, these cages are readily removed. If the fluid being pumped makes mineral deposits (gyp) in the cage bore, this will immediately alert the customer that he should start some type of treating program to protect his complete system.
6. Using magnet or hook, remove valve disc. (Figure 6, page 45).
7. Insert valve seat driver in discharge seat and rock back and forth. This action will loosen the seat and allow it to be removed with the hook. (Figure 7, page 45).
8. Assemble upper valve as removed to keep parts together.
9. Remove seal from top of lower cage.
10. Remove spring with hook. **Note:** Notice if spring had proper pre-load.
11. Remove cages using same procedure as No. 4.
12. Using magnet, remove valve disc.
13. Insert valve seat driver in suction seat and rock back and forth. This action will loosen the seat and allow it to be removed with the hook.
14. Assemble lower valve as removed to deep parts together.
15. Remove bottom seal.
16. Inspect cylinder bore with flashlight paying particular attention to sealing areas.

\*If necessary, repeat the above steps in the remaining cylinder bores.

## Plunger Pump Valves...

### II. CAGE TYPE VALVES

#### C. DISASSEMBLY PROCEDURE (Continued)...

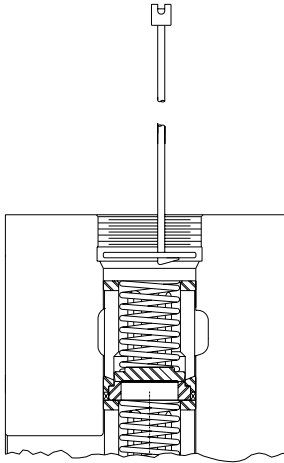

**Figure 4**

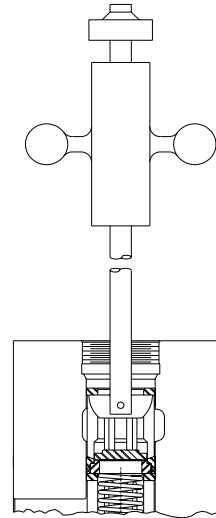

**Figure 5**

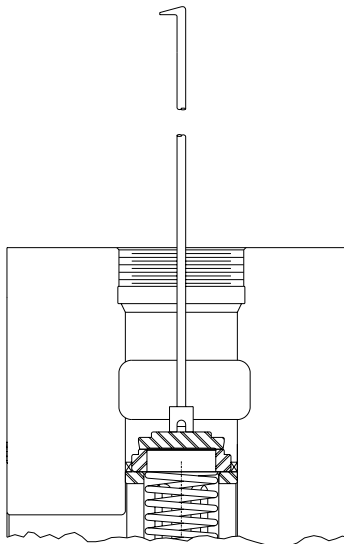

**Figure 6**

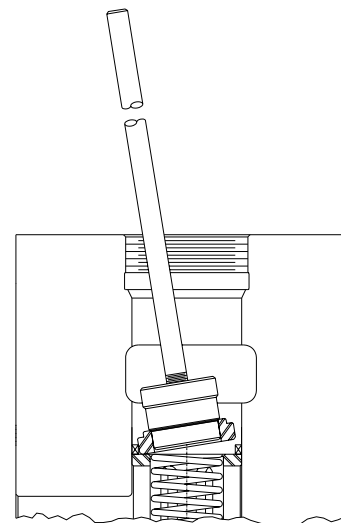

**Figure 7**

## Plunger Pump Valves...

### II. CAGE TYPE VALVES (Continued)...

#### D. VALVE PARTS INSPECTION

##### 1. CAGE (Bottom Guide, Disc, Ball, or Spherical)

The cages used in the National Oilwell Varco Valve Assembly are precision machined and designed for long trouble-free service. Erratic valve action associated with poor suction conditions can cause accelerated wear on this part.

## **! ATTENTION !**

A LOOSE COVER WILL ALLOW CAGE MOVEMENT AND WILL CAUSE EXTENSIVE DAMAGE TO CAGE AS WELL AS FLUID END.

Each cage that is removed should be inspected at the following points referred to in the drawing, Figure 8.

- Inspect for wear in this area. It is best to do this with the valve and seat in the cage, therefore, a more accurate decision can be made. The wear in this area, which can be judged by the sideways movement of the disc, should not exceed  $1/2$  the width of the seating surface of the disc valve or more than  $1/8$ " to  $3/16$ " for the ball valve. These are maximum figures and could result in poor valve action and some loss of efficiency. If in doubt, change the cage.
- Inspect the valve seat shouldering area for signs of wear or hammering. If this portion of the cage is cracked or battered, the cage should be replaced. This will only happen if the cage is allowed to move in the bore due to loose covers.

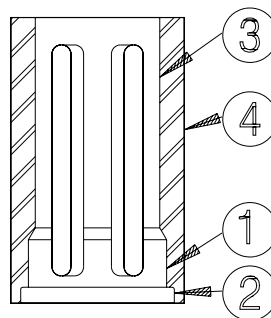

**Figure 8**

- Inspect cage bore for excessive spring. In most cases this area will wear only if there is poor valve action or extremely corrosive water that attacks the cage material in this wear zone.
- Inspect O.D. of cage for nicks, burrs or washers. Clean cage thoroughly before replacing.



## Plunger Pump Valves...

### II. CAGE TYPE VALVES

#### D. VALVE PARTS INSPECTION (Continued)...

##### 2. VALVE, BOTTOM GUIDED AND SEAT

The standard (-25) NATIONAL OILWELL VARCO bottom guided disc and seat is made from a specialty stainless steel, which is strictly resistant to corrosion. An optional heat treated stainless steel (-4) valve is available for less corrosive fluids that contain solids. The standard valve is non-magnetic, so a loop is provided for removal from the fluid cylinder.

The following Inspection points should be observed:

- a. The valve seat and sealing surface should be closely inspected for evidence of excessive wear and /or washed areas. The amount of wear can be determined by comparison with a new valve and seat. Worn valves and seats should be replaced.
- b. Inspect the valve guides and seat bores for guide wear. Valves with excessively worn or broken guides and grooved seats should be replaced.
- c. Inspect the outside surface of the valve and seat for nicks, burrs or washers, and thoroughly clean before assembly.

##### 3. VALVE, SPHERICAL VALVE AND SEAT

The standard NATIONAL OILWELL VARCO spherical valve & seat is made from a specialty stainless steel which is strictly resistant to corrosion. The valve is non-magnetic so a loop may be provided for removal from the fluid cylinder.

The following inspection points should be observed:

- a. The valve seat & sealing surface should be closely inspected for evidence of excessive wear and/or washed areas. The amount of wear can be determined with a new valve & seat. Worn valves & seats should be replaced.
- b. Inspect the outside surface of the valve & seat for nicks, burrs, or washes, and thoroughly clean before assembly.

## Plunger Pump Valves...

### II. CAGE TYPE VALVES

#### D. VALVE PARTS INSPECTION (Continued)...

##### 4. VALVE, DISC AND SEAT

The NATIONAL OILWELL VARCO disc-type valve is made from heat treated stainless steel. An optional 316 stainless steel valve is available for severe corrosive service. The 316 stainless steel valve is non-magnetic and cannot be picked up with a magnet. The heat-treated valve is magnetic:

The following inspection points should be observed (See Figure 9):

- a. The valve and seat sealing surfaces should be closely inspected for evidence of excess wear and/or washed areas. The amount of wear can be determined by comparison with a new valve and seat or by observing the amount of undercut still remaining on the disc seating surface. If this face is flat, the valve disc and probably the seat should be replaced. Small washes or cuts in the seating surface can sometimes be removed with emery cloth. The seating surfaces should then be ground, or polished, to a smooth finish. A good field method is to lay the fine emery cloth or crocus cloth on the milled top of the cylinder and polish the disc and seat on this surface.
- b. Inspect the outside surface of the disc and seat for nicks, burrs, or washes, and thoroughly clean before assembly.

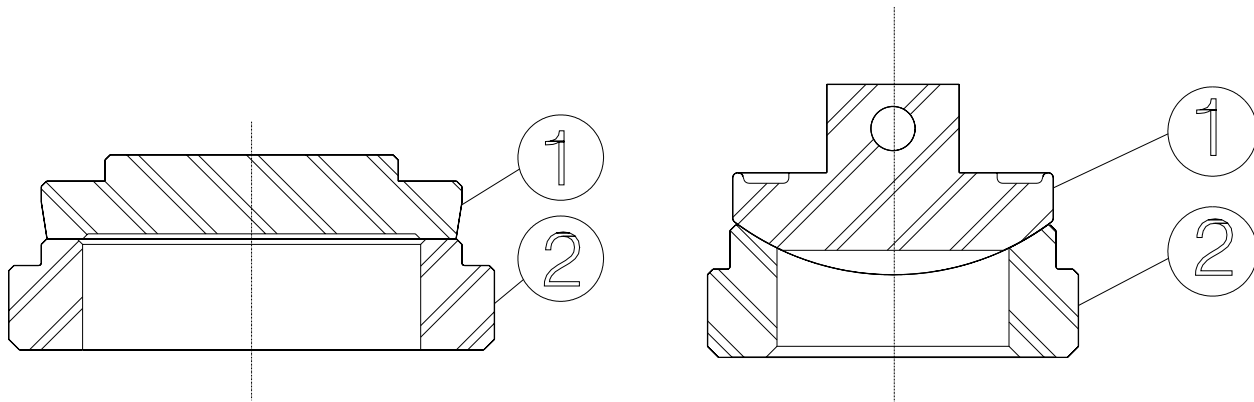

Disc & Seat

Spherical Valve & Seat

Figure 9

## Plunger Pump Valves...

### II. CAGE TYPE VALVES

#### D. VALVE PARTS INSPECTION (Continued)...

##### 5. VALVE, BALL & SEAT

The NATIONAL OILWELL VARCO ball and seat valve is composed of the same material as the Fluid Packed Supreme Ball and Seat. The seat is reversible and the seating surfaces should indicate if replacement is necessary.

##### 6. SPRINGS

The springs as used in the NATIONAL OILWELL VARCO cage-type valve assemblies are designed for long trouble-free service. If installed correctly with the proper pre-load and operated under normal conditions, which include a good suction that provides a smooth valve action, these springs will operate for a year or more.

## **! ATTENTION !**

IT IS BEST YOU CHANGE SPRINGS AND DESTROY THE OLD ONES APPROXIMATELY ONCE A YEAR. IF THE SPRINGS FATIGUE AND BREAK, THE RESULTING VALVE ACTION CAN DAMAGE THE CAGE AND VALVE. HERE AGAIN, IF IN DOUBT, CHANGE THE SPRING; THEIR COST IS VERY MODERATE.

##### 7. SEALS, VALVE CAGE

The NATIONAL OILWELL VARCO cage-type valves are of a stacked design and depend on the seal at the top, middle and bottom of the stack to isolate the suction and discharge valves and their associated changes in pressure. These seals should be changed every time the valves are removed from the pump. If it is absolutely necessary to re-use these seals, install the best seal in the middle stack, the next best at the bottom and the worst seals on the top covers. Replace used seals with new ones as soon as possible.

## Plunger Pump Valves...

### II. CAGE TYPE VALVES (Continued)...

#### E. ASSEMBLY PROCEDURES

1. After all parts have been thoroughly inspected and cleaned, assemble each valve unit on top of the pump **leaving off the seals**. Make certain the seat is shouldered up in the cage and the spring is correctly positioned on the disc. Now, check the spring for correct pre-load which should be with 1/8" to 3/16" of spring extending above top of cage. (See Figure 10, page 52.)
2. Check cylinder bores for nicks, scratches, cuts or washed areas with flashlight. Fluid end should be reworked if these are too deep for seal to work effectively.
3. Place new seal in cylinder bore and push to bottom with hook. Gently tamp the seal into the bottom of the bore. (See Figure 11, page 52).
4. Using handle of seat driver as a guide, drop a suction seat on top of gasket. The handle will prevent the seat from turning over when dropped.

**NOTE:** Suction seat has a larger bore (I.D.) than the discharge seat.

5. Insert seat driver in suction seat, and using a hammer, tap the seat into seal until it is solid with bottom of bore. (Check seat, be certain top side is up). (See Figure 12, page 52).
6. Place Valve disc on magnet with spring in position on top of valve disc, and lower into place on top of seat. Leave magnet standing in bore.

**NOTE:** Valve discs are interchangeable between suction and discharge seats. (See Figure 13, page 52).

7. Insert cage in bore, using handle of seat driver, tap cage gently to the bottom.

**NOTE:** The cages fit the bores very closely. Use care when inserting the cage to be sure it is not cocked. Work the cage gently - it will slide into the bore when correctly aligned.

*Lift the valve disc with the magnet to make certain it is not caught under the cage, and using a hammer, gently drive the cage down until solid. (See Figure 14, page 52).*

8. Check disc spring to see that they are free in the cage. Pull magnet loose. (Figure 15, page 52).
9. Using a flashlight, check the spring for correct positioning on valve disc and for proper pre-load. Check valve disc to be certain top side is up. (See Figure 15, page 52).
10. Place seal in cylinder bore and push to top of suction cage with hook. Gently tamp seal into position.
11. Drop discharge seat using handle as described in No. 4.
12. Drive seat solid on top of cage. In some cases, the pre-load from the suction spring will push the seat up after it is driven - this is normal.

## Plunger Pump Valves...

### II. CAGE TYPE VALVES

#### E. ASSEMBLY PROCEDURES (Continued)...

13. Place valve on magnet with spring in position and lower into place on top of seat. Leave magnet standing in the bore.
14. Insert cage and drive using the same procedure as No. 7.
15. Inspect using same procedure as No. 7.
16. Check valve assembly with flashlight using same procedure as No. 8.
17. Place seal on retainer and install in cylinder. Screw threaded cover down by hand until threads are fully engaged. Torque center bolts to following values:

PLUNGER PUMP SIZE	TORQUE (Dry)	TORQUE (Lubricated)
30T-2H, 30T-2L, 60T-3H, 60T-3M, 80T-3H, 80T-3M	500 ft-lbs	400 ft-lbs
100T-4H, 100T-4M, 130T-4H, 130T-4M, 165T-5M, 300Q-5HA, 200T-5H, 250T-5H	550 ft-lbs	450 ft-lbs
165T-5M, 300Q-5M, 200T-5M, 250T-5M	650 ft-lbs	525 ft-lbs
165T-5H, 200T-5H, 250T-5H, 300Q-5HB	900 ft-lbs	735 ft-lbs
375T-7H	1300 ft-lbs	1060 ft-lbs

## Plunger Pump Valves...

### II. CAGE TYPE VALVES

#### E. ASSEMBLY PROCEDURES (Continued)...

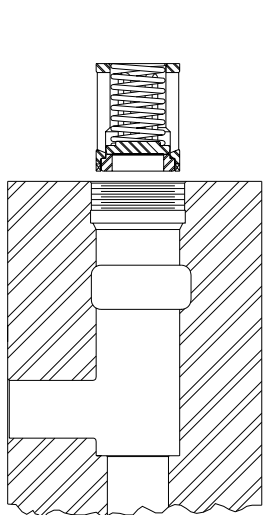

Figure 10

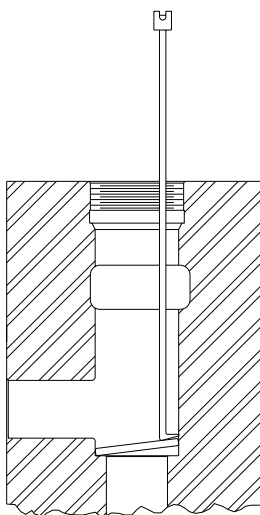

Figure 11

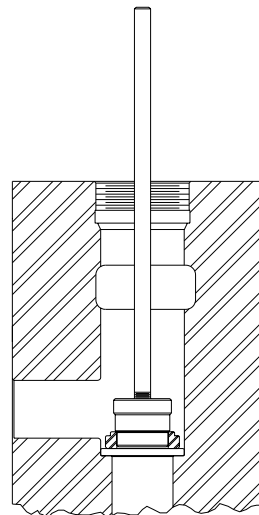

Figure 12

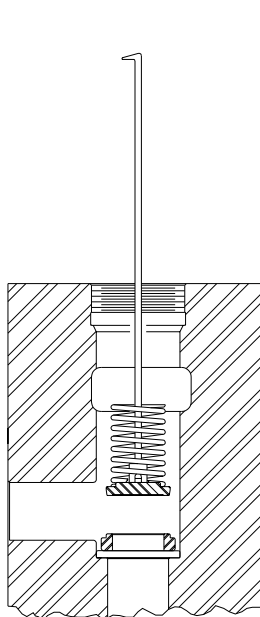

Figure 13

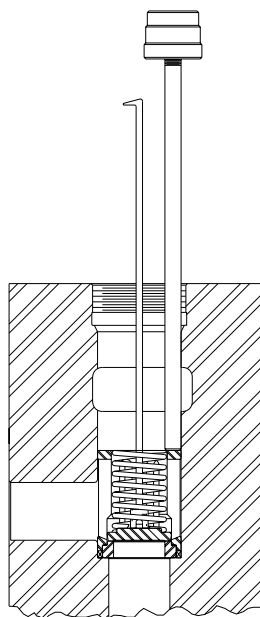

Figure 14

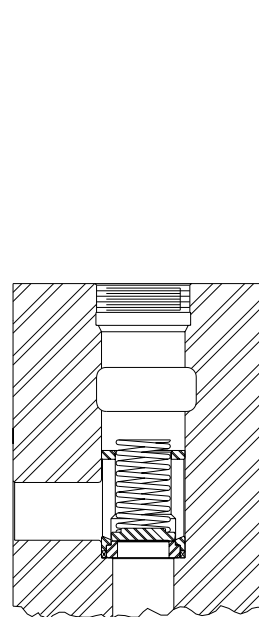

Figure 15

## Plunger Pump Valves (Continued)...

### III. TAPERED SEAT VALVES

#### A. SPHERICAL VALVES and SEATS

##### 1. VALVE REMOVAL PROCEDURE

- a. Both suction and discharge valves are removed from the top of the cylinder. It is necessary to pull the discharge valve prior to pulling the suction valve.
- b. Remove the spring retainer by pressing downward on the puller head and turn counter clockwise about 1/8 of a turn or until retainer stops. Remove the retainer with the retriever. See Figure 17.
- c. Remove spring(s) and valve with the retriever. See Figure 18.
- d. Remove seat by placing the puller head through the seat opening and engage lugs to the underside of the seat. Pull seat or bump seat loose and remove. See Figure 19.

##### 2. INSTALLATION PROCEDURE

- a. Make certain cylinder tapers are clean and dry. Inspect for corrosion or damaged areas. Repair or replace as required.
- b. Clean and dry spherical seat tapers and with retainer and spring(s) removed, place seat in place making certain it is straight.
- c. With a bar and a driver tap seat in place with 2 or 3 strokes. **NOTE!!** Seat does not have to be completely seated. Pump start-up pressure will drive seat home. See Figure 20.
- d. Install valve, spring(s), and spring retainer. See Figure 21.

## Plunger Pump Valves...

### III. TAPERED SEAT VALVES

#### A. SPHERICAL VALVES and SEATS (Continued)...

VALVE COMPLETE, Consists of:						
ITEMS INCLUDED		2-1/2"	3"	3-1/2"	4"	5"
VALVE COMPLETE	SUCTION	1792520-25	1793020-25	1793520-25	1794020-25	1795020-25
	DISCHARGE	1792522-25	1793022-25	1793522-25	1794022-25	1795022-25
SEAT	SUCTION	1792521-25	1793021-25	1793521-25	1794021-25	1795021-25
	DISCHARGE	1792523-25	1793023-25	1793523-25	1794023-25	1795023-25
VALVE (ONLY)		1792527-25	1793027-25	1793527-25	1794027-25	1795027-25
SPRING (SUCTION)		1792525	1793025	1793525	1794025	1795025
RETAINER		1792524-6	1793024-6	1793524-6	1794024-6	1795024-6
SPRING (DISC)	INNER	1792526	1793026	1793526	1794026	NONE
	OUTER	1792525	1793025	1793525	1794025	1795025

PULLER KIT, Consists of:					
ITEMS INCLUDED	2-1/2"	3"	3-1/2"	4"	5"
PULLER KIT	180104119	180104127	180104135	180104143	180104151
PULLER HEAD	181205709	181259300	181259359	181259409	181259410
RETRIEVER	1790034				
SPACER	181205709				181205710
WASHER	20-220-194				20-220-327
NUT	75-518-308				75-510-330



**Plunger Pump Valves...**

**III. TAPERED SEAT VALVES**

**A. SPHERICAL VALVES AND SEATS (Continued)...**



**Figure 16**

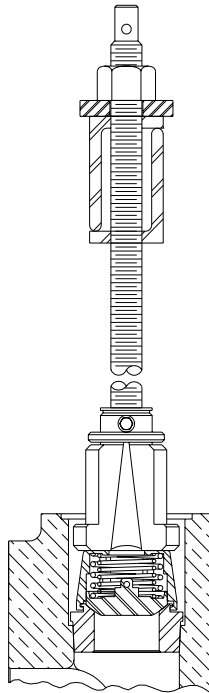

**Figure 17**

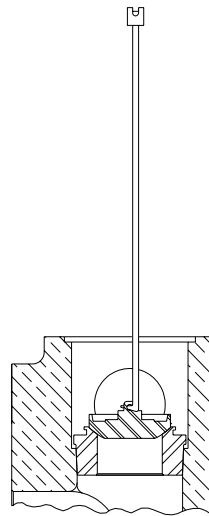

**Figure 18**

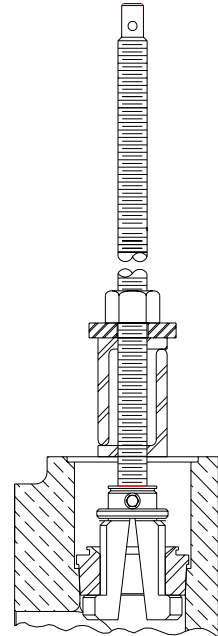

**Figure 19**

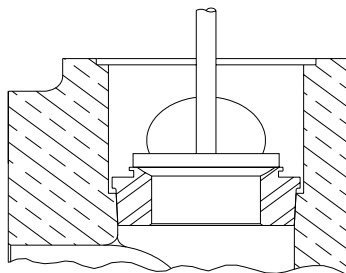

**Figure 20**

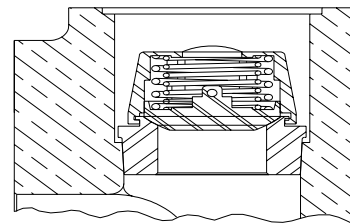

**Figure 21**

## Plunger Pump Valves (Continued)...

### III. TAPERED SEAT VALVES

#### B. TAPERED SEAT-BOTTOM GUIDED VALVES

##### 1. VALVE REMOVAL PROCEDURE

- a. Using hex head wrench as shown in Figure 23, remove retainer and spring. Bottom guided valves can be removed with a magnet or special valve retriever.
- b. Screw puller head on valve seat until tightly shouldered. Valve seat can be pulled or bumped as shown in Figure 24.

##### 2. INSTALLATION PROCEDURE

- a. Make certain fluid end tapers are clean and dry. Inspect for corrosion or damaged areas to see if repair is required.
- b. Clean and dry valve seats tapers and with retainer and spring removed, place seat in place making sure it is straight.
- c. With bottom guided valve in place, drive the seat, as shown in Figure 25, until it stops driving.
- d. Check bottom-guided valve to be sure it is free in the seat and install spring and retainer. Torque retainer to values shown below using hex head wrench as shown in Figure 26.

TORQUE ft.-lbs.	2-1/2"	3"	3-1/2"	4"
	100	100	100	100

## Plunger Pump Valves...

### III. TAPERED SEAT VALVES

#### B. TAPERED SEAT-BOTTOM GUIDED VALVES (Continued)...

<b>VALVE COMPLETE, Consists of:</b>					
<b>ITEMS INCLUDED</b>		<b>2-1/2"</b>	<b>3"</b>	<b>3-1/2"</b>	<b>4"</b>
VALVE (Complete) .....	Suction	1792500-4	1793000-4	1793500-4	1794000-4
	Discharge	1792502-4	1793002-4	1793502-4	1794002-4
SEAT .....	Suction	1792501-4	1793001-4	1793501-4	1794001-4
	Discharge	1792503-4	1793003-4	1793503-4	1794003-4
VALVE (Only).....		1790066	1713502	1790067	1790068
SPRING .....		1792505	1793005	1793505	1794005
RETAINER.....		1792504-26	1793004-26	1793504-26	1794004-26

<b>PULLER KIT, Consists of:</b>					
<b>ITEMS INCLUDED</b>		<b>2-1/2"</b>	<b>3"</b>	<b>3-1/2"</b>	<b>4"</b>
PULLER KIT		1792507	1793007	1793507	1794007
PULLER HEAD		1792506	1793006	1793506	1794006
BUMPER			1790080		
BAR			1790081		
WRENCH			1790082		
RETRIEVER			1790034		
SUPPORT			1713109		
NUT			6300160		
FLANGED NUT			6314002		

## Plunger Pump Valves...

### III. TAPERED SEAT VALVES

#### B. TAPERED SEAT-BOTTOM GUIDED VALVES (Continued)...

#### REMOVAL

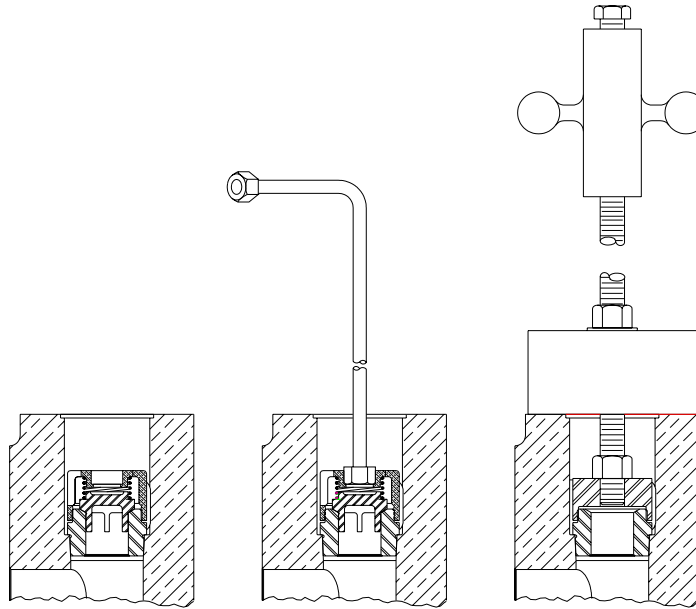
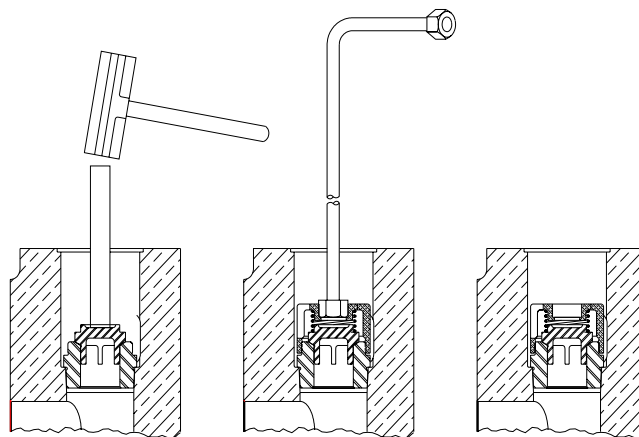

**Figure 22**

**Figure 23**

**Figure 24**

#### INSTALLATION



**Figure 25**

**Figure 26**

**Figure 27**

## Gear Reducer...

### I. LUBRICATION AND MAINTENANCE

#### A. GENERAL

NATIONAL OILWELL VARCO plunger pump gear reducers are "splash" lubricated. The rotation of the gears provides adequate lubrication to all working parts. The gear reducer housing and the plunger pump power end are separated by a labyrinth oil seal on the 30T, and a labyrinth oil seal retainer on the 60T, 80T, 100T, 130T, 165T, 200T, 250T and 300Q. These seals separate the lubricating oils and prevent contamination.

Initial filling should be through the hand hole cover and can be gauged by the high and low level oil plugs in the housing. Correct level is at the bottom of the high level plug.

#### 1. OIL

Use an extreme pressure gear oil. The following chart shows the recommended grades for various temperatures surrounding the pump.

U.S. UNITS OF MEASURE	
Temperature	AGMA Industrial EP Gear Oil
+50°F to +155°F	AGMA No. 6 EP or ASTM/ISO Grade No.320 (Viscosity 1335 to 1632 SSU at 100°F)
+20°F to +100°F	AGMA No. 5 EP or ASTM/ISO Grade No.220 (Viscosity 918 to 1122 SSU at 100°F)
+20°F to +60°F	AGMA No. 2 EP or ASTM/ISO Grade No.68 (Viscosity 284 to 347 SSU at 100°F)

METRIC UNITS OF MEASURE	
Temperature	AGMA Industrial EP Gear Oil
+10°C to +68°C	AGMA No. 6 EP or ASTM/ISO Grade No.320 (Viscosity 288 to 352 cSt at 37.8°C)
-7°C to +38°C	AGMA No. 5 EP or ASTM/ISO Grade No.220 (Viscosity 198 to 242 cSt at 37.8°F)
-29°C to +16°C	AGMA No. 2 EP or ASTM/ISO Grade No.68 (Viscosity 61 to 75 cSt at 37.8°F)

Oil must pour freely at a minimum operating temperature. Change oil every six months or as frequently as operating conditions require to maintain a clean, sludge-free oil of proper viscosity.

## Gear Reducer...

### I. LUBRICATION AND MAINTENANCE

#### A. GENERAL

##### 1. OIL (Continued)...

GEAR REDUCER OIL CAPACITY			
Pump	Ratio	Gal.	Ltr.
30T	3.50, 3.83, 4.20	2/3	2.5
60T, 80T	2.34, 2.77, 3.035, 3.50	1	3.8
100T, 130T	2.60, 3.15, 3.42, 3.89, 4.269	3	11.4
165T	2.80	3-1/2	13.3
	3.22, 3.46	3	11.4
	3.73	2-3/4	10.4
	4.00, 4.38, 4.78, 4.96, 5.74	2-1/4	8.5
200T	2.27	6-1/2	24.6
250T	2.89	5	18.9
300Q	3.25, 3.36, 3.69	4-1/2	17.1
	4.38, 4.84, 5.63	3-1/2	13.3

##### 2. MAINTENANCE

- a. The gear reducer housing is equipped with a magnetic drain plug that will collect any steel particles and prevent them from being recirculated with oil. This plug should be cleaned every six months.
- b. The gear reducer should be drained, flushed and refilled every six months or as often as required to maintain clean, sludge-free oil of the proper viscosity.
- c. Clean air breather with a non-explosive solvent.

## **Gear Reducer (Continued)...**

### **II. OVERHAUL AND REPAIR**

#### **A. GENERAL**

The bearings and other working parts in the plunger pump gear reducers have been designed for continuous duty service; and if proper maintenance is given, will provide years of trouble-free service. If overhaul and repairs are necessary, disassembly and assembly procedures are discussed below.

#### **1. DISASSEMBLY**

- a. Remove housing cover bolts, and using threaded jackscrew holes, pull the cover and tapered dowel pins.
- b. Remove pinion shaft and Timken bearings from housing.
- c. Remove blind cover plate.
- d. Tap out Timken outer cup and mark all parts for correct replacement position.
- e. Pull crankshaft gear. Gear is a .001" to .005" shrink fit to shaft. Puller holes are provided in gear for pulling. (30T - 5/8" holes; 165T and 300Q - 1" holes). Heat should be used when pulling gears, but a combination of dry heat and dry ice can also be used. The puller should be attached to the gear and a heavy strain should be applied. The gear should be heated with a large tip torch starting at the outside gear rim below the root of the teeth, and working in a circular motion, heat the gear slowly and evenly toward the hub. The torch should be kept in constant motion to prevent hot spots. The gear rim should always be kept at a temperature above the hub area to eliminate tensile stresses in the gear rim, which causes the gear to crack. The gear will break loose from the shaft when enough heat has been applied. The puller should then be able to remove the gear. Do not exceed 350°F at any time on the surface of the gear. Use a tempil stick to gauge the temperature.
- f. A gear removed in this manner will be a serviceable gear.

## **! ATTENTION !**

EXCESS HEAT OR SPOT HEATING WILL CAUSE THE GEAR TO CRACK OR DISTORT.  
ALLOW GEAR TO COOL SLOWLY.

## Gear Reducer...

### II. OVERHAUL AND REPAIR

#### A. GENERAL (Continued)...

##### 2. ASSEMBLY

**NOTE:** Items 1 through 4 may be omitted if the pump is equipped with a new style main bearing cage; 100T & 130T - Part Number 1711617. Omit items 1 through 4 for all 30T, 60T, 80T, 165T, 200T, 250T and 300Q.

- a. Remove crankshaft assembly and left hand main bearing and cage assembly as per pump service manual.
- b. Install a new cage and bearing per assembly instructions in pump service manual.
- c. Install new bearing retainer (100T & 130T - Part number 1711622) and gasket onto cage. Check clearance of Labyrinth seal to shaft. There should **not** be any metal-to-metal contact.
- d. Install crankshaft assembly per instructions in pump service manual.
- e. 60T & 80T only - replace left hand bearing retainer, Part Number 1710011, with new bearing retainer, Part Number 1710618, and re-shim crankshaft as per instructions in service manual. This retainer contains labyrinth oil seals, but some older models use two (2) YS-3254 seals with the lips pointed in opposite directions.
- f. All other pumps contain labyrinth seal type retainers. No oil seals are necessary. Be sure seal grooves are clean before installing retainer.
- g. Apply liquid gasket to bearing cage and install gear reducer housing over pilot on bearing cage. Insert special capscrews and tighten securely.
- h. Drill and ream for dowel pins - two (2) holes. Dowel pins are standard .25" per foot taper pins and are listed in the parts list section for each pump.

## **! ATTENTION !**

*DO NOT DRILL THROUGH PUMP FRAME. HOLES SHOULD BE REAMED DEEP ENOUGH TO ALLOW PINS TO BE DRIVEN UNTIL THE TOP OF THE TAPER ON PIN IS FROM FLUSH TO 1/8" STAND-OFF.*



## Gear Reducer...

### II. OVERHAUL AND REPAIR

#### A. GENERAL

#### 2. ASSEMBLY (Continued)...

- i. After taper pins are fitted and driven, re-check tightness of special capscrews by torquing to following values and wire them in place.

PUMP SIZE	SPECIAL CAPSCREW	TORQUE (Ft. – lbs.)
30T	2402010	75
60T, 80T	2402850	150
100T, 130T	2405029	75
165T	2403190	150
200T, 250T, 300Q	2405018	375

- j. Check high-speed pinion for nicks and burrs in bearing areas and remove same.
- k. Heat pinion tapered roller assemblies in electric oven or bath to 300° F and install on pinion shaft. Make sure bearings are shouldered on shaft.
- l. Install outer race of tapered roller assemblies in housing and cover.
- m. With half the shims on the blind retainer, install and secure with screws.
- n. Check crankshaft extension, keyway crankshaft gear and key nicks and burrs - remove same.
- o. Heat the crankshaft gear to 350° F in an oil bath or furnace to insure even and uniform heating. If these methods are not available, heat the gear with a large top torch as described in paragraph 1. e., page 61. It is of prime importance that the gear be heated slowly and evenly from the gear rim to the hub. Use a tempil stick and micrometers to assure a correct fit. Allow gear to cool slowly.
- p. Slip gear on shaft with under cut area on hub facing toward pump; puller holes facing out. Position gear on shaft so that distance from end of shaft to outside face of hub is as follows:

PUMP	END OF SHAFT TO HUB FACE
30T	1-3/4"
60T, 80T	2-5/15"
100T, 130T	4-1/4"
165T	4-3/8"
200T, 250T, 300Q	6-1/2"

- q. Insert key with beveled side next to shaft and allow to cool in place.

## Gear Reducer...

### II. OVERHAUL AND REPAIR

#### A. GENERAL

##### 2. ASSEMBLY (Continued)...

## ! IMPORTANT !

- MAKE SURE GEAR IS HOT ENOUGH AND INSTALLATION IS PERFORMED QUICKLY ON THE SHAFT BEFORE IT IS POSITIONED.
- MAKE SURE KEYWAYS ARE ALIGNED WHEN SHRINKING GEAR ONTO SHAFT.
  - r. Position high-speed pinion in housing supporting same with rope or cloth through the hand hole in top of housing.
  - s. Apply liquid gasket between cover and housing. Install the housing cover and secure with capscrews and taper pins.
  - t. Place remaining shims on open retainer and install with screws, making certain the drain slot is at the bottom. Adjust with shims and retainers until the endplay of the pinion shaft is from .003" to .005" loose on all reducers except 200T and 300Q where the end play is from .005" to .007" **loose**. Check clearance of Labyrinth seal to shaft. There should **not** be any metal-to metal contact.

## ! IMPORTANT !

- MAKE CERTAIN THE BEARING OUTER CUPS ARE SOLID AGAINST THE RETAINERS AND THE OUTSIDE RETAINER IS INSTALLED CORRECTLY.
  - u. Check meshing of pinion and crankshaft gear.
  - v. Install pinion shaft dirt excluder.

##### 3. INSTALLATION

Since the plunger pump gear reducer is attached to the pump and becomes a part of the pump package, the installation should receive the same careful consideration that the pump itself does. Careful installation practices will greatly increase trouble-free operation and reduce maintenance costs. For general installation recommendations, see Installation Section of the pump manual.

## P-55U Pump...

### A. OPERATING INSTRUCTIONS

#### 1. BOX SUCTION PUMPS (VACUUM FEED)

- Fill reservoir with oil.
- Loosen union nut on pump outlet.
- Remove the vent screw and fill the sight glass with oil. Prime by manually pumping flushing unit until air free oil is observed from the drip tube and oil level drops in the sight glass.
- Replace vent screw and tighten union nut.
- Maintain oil level in sight glass below the drip tube so drops can be observed.

#### 2. FLOW RATE ADJUSTMENT

- Loosen locknut on flushing unit.
- Turn flushing unit counter-clockwise to increase flow.
- Turn flushing unit clockwise to decrease flow.
- Tighten locknut when desired flow rate is achieved.

#### 3. SIGHT GLASS

In a vacuum type sight feed, it is not uncommon for oil level in the sight glass to drop during operation. Absence of a level indicates air is being taken in with the oil. Some oils, due to viscosity conditions, will release air faster than others. When the quality of air becomes excessive, it can eventually air lock the pump.

*For this reason it is recommended that an oil level in the sight glass be maintained.*

When level drops, remove the vent screw and fill sight glass to top; replace vent screw and operate flushing unit manually, observing that an oil in the sight glass is free from air. If air is not expelled, it may be necessary to loosen union nut (on pump outlet) and expel air at this point. It is desirable to maintain level below the drip tube so drops can be seen during operation.

#### 4. OVERFILLING OF SIGHT GLASS

In a vacuum type sight feed, it is not uncommon to see a reverse action whereas sight glass fills with oil and the drops cannot be observed. Overfilling is caused by oil absorbing air in the sight glass and normally does not affect the operation of the pump. Remove the vent screw from sight glass and allow level to drop below drip tube. Tighten vent screw and check to see that air free oil from drip tube can be observed in the sight glass. If overfilling continues, it may be caused by plunger wear and oil slippage is being drawn back to sight glass. If this is the problem, the feed setting in drops per stroke will then automatically be reduced by the amount of slippage.

#### 5. RESERVOIR OIL LEVEL (LOSS OF PRIME)

If reservoir runs low on oil (at a point below the suction inlet of the pump) it may be necessary to prime individual pumps after filling, using procedure listed above.

#### 6. PUMP DISPLACEMENT

Maximum output (per stroke):

1/4 Plunger = .018 Cubic Inches  
3/8 Plunger = .038 Cubic Inches

The cubic volume for a pint of oil is 28.9 cubic inches and average drop size is .002 cubic inches.

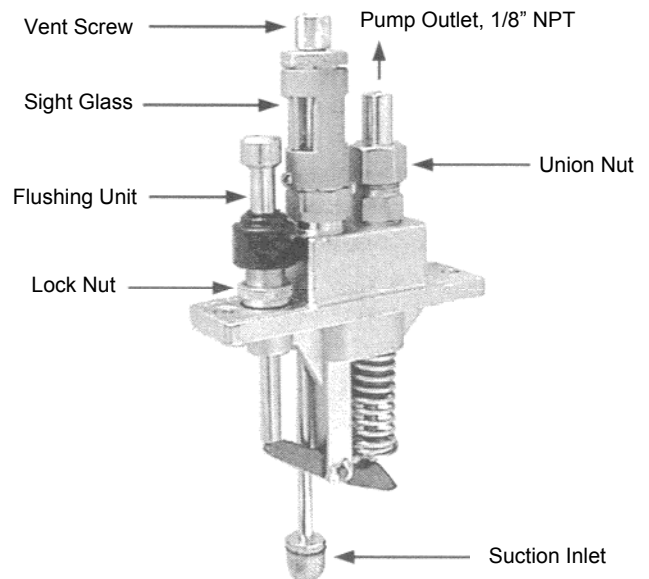

## Storage of Pumps...

### I. GENERAL

All machinery units require protection from corrosion erosion, natural attrition which causes deterioration of the surface as well as the working parts. Generally, units in operation are frequently inspected, cleaned, painted and lubricated while idle units are often more or less neglected. Any degree of neglect is costly, especially if continued over a sufficient period of time to make restoration of the equipment impossible. It is recommended that preventive measures of protection be established and the following will guide you in the minimum requirement.

### A. GENERAL

Preferably, units should be stored in clean, climatically controlled buildings. This would require the minimum inspection, but, since storage in older environments is sometimes necessary, more frequent inspections and additional protection is necessary. The schedule for inspection and protection can be determined only at the point of storage. A protection and storage log is recommended. Tropical areas require the maximum protection; arid regions require the least amount of protection. The frequency of inspection is determined after noting the rate of deterioration. Take positive action immediately when corrosion/erosion appears, do not wait until large areas are covered because usually the larger the area, the deeper the penetration.

### B. RECOMMENDED PROTECTION INITIAL STORAGE

1. Drain all oil and thoroughly clean inside of Power Frame.
2. Coat pinion shaft oil seals with grease.
3. Remove breathers for later installation on pump. Seal all breather holes with greased solid pipe plugs. Remove extension rods and diaphragm sealing housing; be sure to protect the rods and housings, storing them separately for later installation on the pump. Seal diaphragms with wooden covers. "Mate" the wood cover and diaphragm faces together, thoroughly coating with Rust Veto 342 or its equivalent.
4. Spray two gallons of Shell VSI 100 vapor phase inhibitor or equivalent into power end of pump.
5. Remove valves and valve springs. Clean and wrap in corrosion inhibiting paper. Remove liners and pistons. Clean and wrap in corrosion inhibiting paper. Clean and dry fluid end bores and thoroughly coat all internal surfaces with Tectyl 506 or equivalent.
6. Thoroughly coat all threads and end of valve cover and screw into fluid end.
7. Protect all external machine surfaces using Rust Veto 342 or equivalent including pump pads.
8. Inspect complete pump and record all details on the Protection and Storage Log.

## Storage of Pumps...

### I. GENERAL (Continued)...

#### C. SIX MONTH SERVICING

1. Rotate pump.
2. Renew internal rust inhibitors to specifications and quantities previously stated under the “Initial Storage” section.
3. Before replacing top and side covers, inspect for any internal corrosion.
4. Inspect for soundness of external protection, i.e., rust preventative and paint. Renew as necessary.
5. Enter and record all details on the “Protection and Storage Log”.

#### D. PRE-INSTALLATION CHECK AFTER STORAGE

1. Repeat six month servicing procedure as stated above.
2. Ensure all necessary parts are complete and in a satisfactory condition for installation on pump.
3. Enter all records and close out the “Protection and Storage Log”.

## Owners Record...

NAME \_\_\_\_\_

LOCATION \_\_\_\_\_

DATE OF DELIVERY \_\_\_\_\_ DATE PLACED IN OPERATION \_\_\_\_\_

PUMP MODEL \_\_\_\_\_

PUMP SIZE \_\_\_\_\_ SERIAL NO. \_\_\_\_\_

PRIME MOVER \_\_\_\_\_ SERIAL NO. \_\_\_\_\_

GEAR UNIT \_\_\_\_\_ SERIAL NO. \_\_\_\_\_

DRIVE:

DRIVE SHEAVE P.D. \_\_\_\_\_ DRIVEN SHEAVE P.D. \_\_\_\_\_ NO. OF GROOVES \_\_\_\_\_

BELT LENGTH \_\_\_\_\_ DRIVE SPROCKET \_\_\_\_\_ CHAIN SIZE \_\_\_\_\_

CHAIN LENGTH \_\_\_\_\_ COUPLING (MAKE) \_\_\_\_\_ COUPLING SIZE \_\_\_\_\_

PRESSURE \_\_\_\_\_ VOLUME \_\_\_\_\_ PUMP SPEED \_\_\_\_\_ DRIVE SPEED \_\_\_\_\_

PLUNGERS \_\_\_\_\_

PACKING \_\_\_\_\_

PISTONS \_\_\_\_\_

LINERS \_\_\_\_\_

VALVES \_\_\_\_\_

SEATS \_\_\_\_\_

LUBRICANTS:

CRANK CASE \_\_\_\_\_

FLUSHING SYSTEM \_\_\_\_\_

GEAR UNIT \_\_\_\_\_

LUBRICATOR \_\_\_\_\_

PRIME MOVER \_\_\_\_\_

COUPLING \_\_\_\_\_

NOTES \_\_\_\_\_

\_\_\_\_\_

\_\_\_\_\_

\_\_\_\_\_

All of the above entries are not applicable to a specific unit; therefore, completion of this form must be confined within the limits of each pump and the specified optional accessory equipment.

**Typical Waterflood Pump Installation Suction and Discharge Piping Arrangement...**

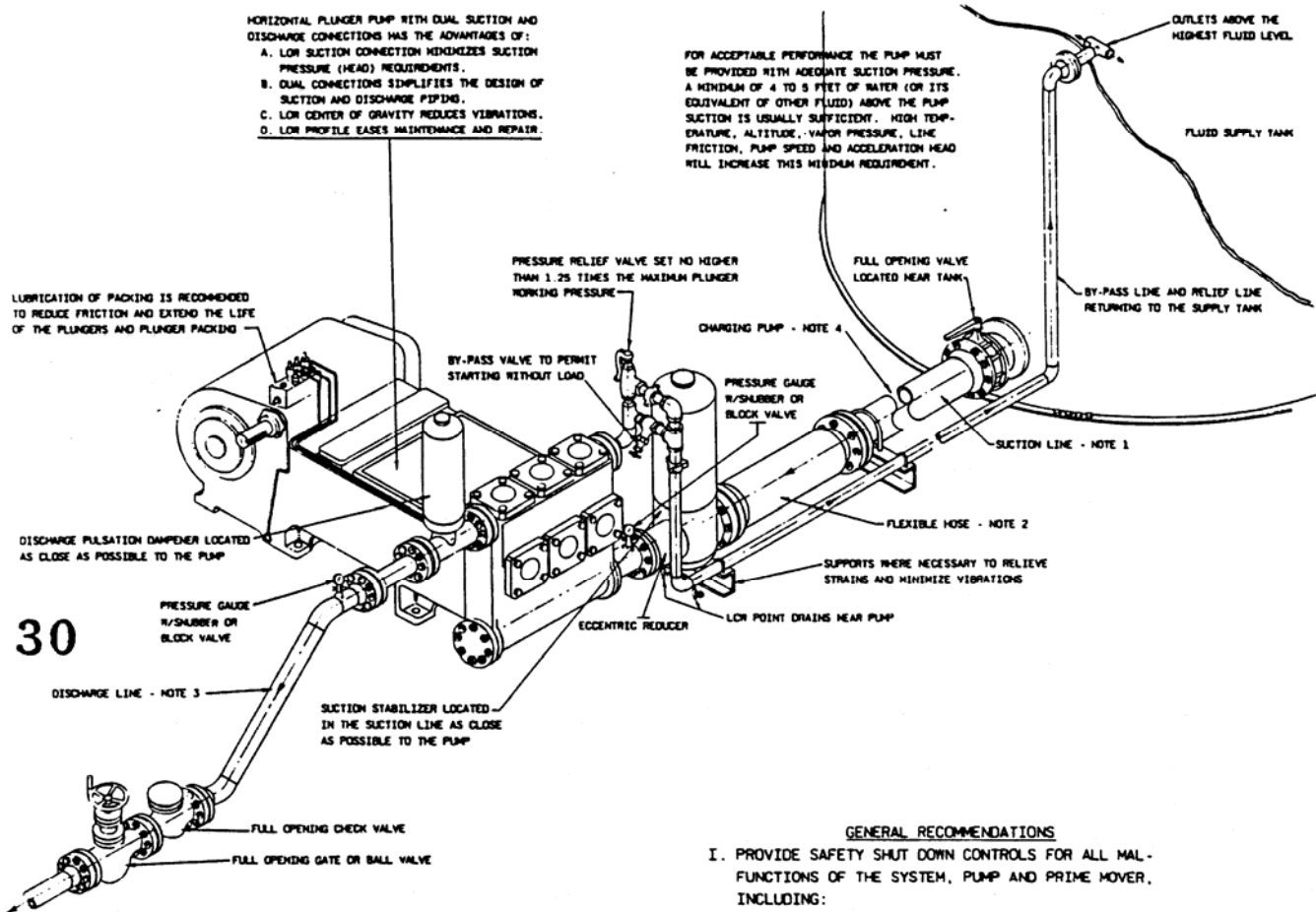

30

**NOTES**

1. A SEPARATE SUCTION LINE IS RECOMMENDED FOR EACH PUMP. THE LINE SHOULD BE A MINIMUM OF ONE SIZE LARGER THAN THE PUMP SUCTION FLANGE OR OPENING TO PROVIDE A MAXIMUM OF 1 TO 2 FEET/SECOND FLUID VELOCITY. IF BENDS ARE NECESSARY USE ONLY 45° LONG RADIUS ELLS. A SLOPE OF 1/4" PER FOOT FROM TANK TO PUMP IS RECOMMENDED.
2. A FLEXIBLE HOSE AND/OR EXPANSION JOINT IN THE SUCTION LINE (ALSO DISCHARGE LINE) PROVIDES FOR THERMAL EXPANSION AND TENDS TO DAMPEN VIBRATIONS.
3. DIRECT THE DISCHARGE LINE, USING 45° LONG RADIUS ELLS, TO GRADE OR BELOW GRADE LEVEL AS SOON AS POSSIBLE TO RELIEVE STRAIN AND REDUCE VIBRATIONS. THE LINE SIZE SHOULD BE SUFFICIENT NOT TO EXCEED A MAXIMUM FLUID VELOCITY OF 8 TO 10 FEET/SECOND.
4. IF CHARGING PUMP IS USED IT SHOULD BE LOCATED NEAR THE SUPPLY TANK. IN ITS SELECTION GIVE CONSIDERATION TO THE FLUID PUMPED, VELOCITY, PLUNGER PUMP VALVING, LINE FRICTION, ETC. SIZE CHARGE PUMP TO 1-1/2 TIMES RECIPROCATING PUMP VOLUME CAPACITY, MINIMUM.

**GENERAL RECOMMENDATIONS**

- I. PROVIDE SAFETY SHUT DOWN CONTROLS FOR ALL MALFUNCTIONS OF THE SYSTEM, PUMP AND PRIME MOVER, INCLUDING:
  - A. LOW SUCTION PRESSURE OR LOW TANK LEVEL
  - B. LOW DISCHARGE PRESSURE
  - C. HIGH DISCHARGE PRESSURE
  - D. LOW OIL PRESSURE OR LOW OIL LEVEL
  - E. HIGH TEMPERATURE, EXCESSIVE VIBRATIONS, OVERLOADING OF PRIME MOVER, ETC.
- II. FOR SERVICING AND SAFETY PROVIDE ADEQUATE WORK AREA AROUND THE PUMP UNIT.
- III. CARE AND OPERATIONS SHOULD INCLUDE CLEANLINESS, DAILY INSPECTIONS, PERIODIC INSPECTIONS, ROUTINE MAINTENANCE AND PREVENTIVE MAINTENANCE.

ISSUE DATE:			
<b>NATIONAL - OILWELL</b>			
<b>TYPICAL WATERFLOOD PUMP INSTALLATION SUCTION &amp; DISCHARGE PIPING ARRANGEMENT</b>			
	SIZE	DRAWING NO.	REV
	<b>C</b>	<b>GSK-3886P</b>	

## Viscosity Equivalents...

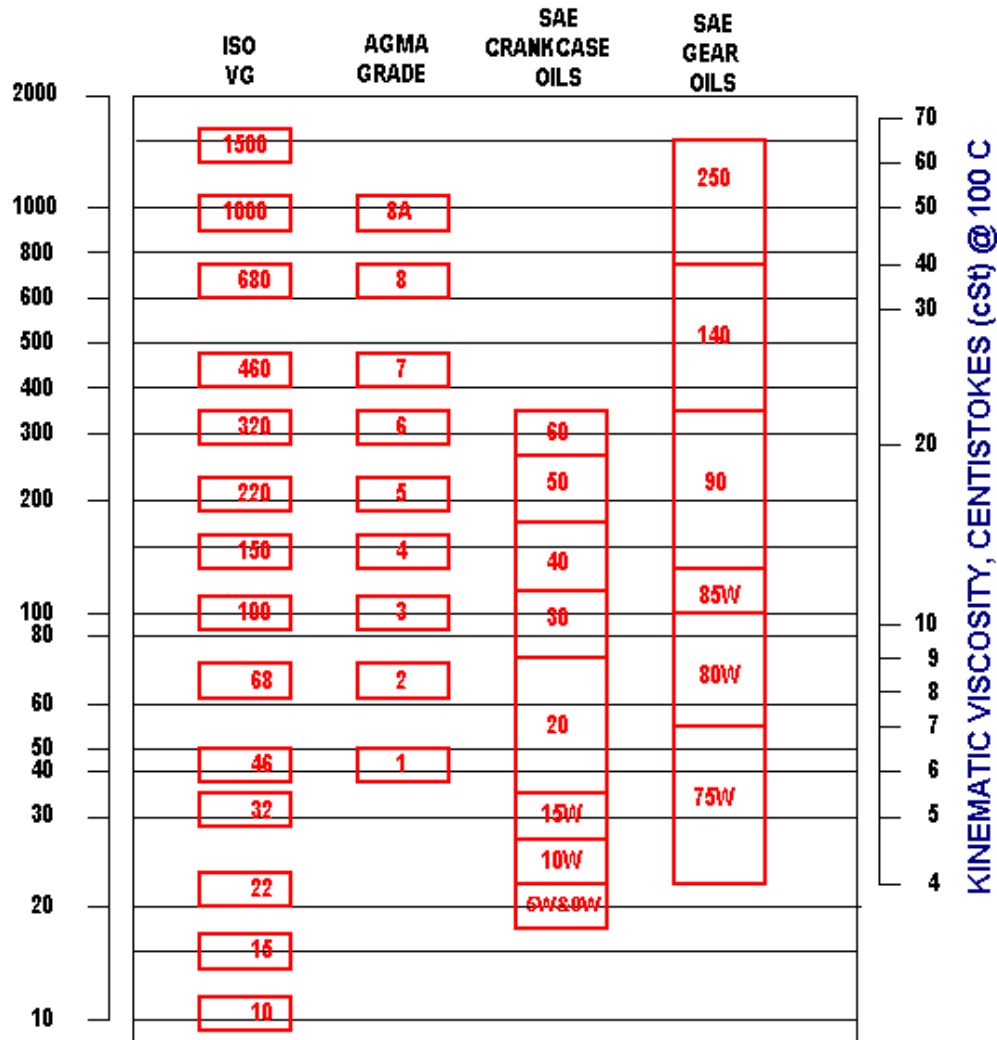

**NOTES:**

- \*Assumes 100 VI single grade oils. Read across horizontally.
- \*SAE grades based upon viscosity at 100 C. ISO and AGMA grades based upon viscosity at 40 C
- \*Equivalence is in terms only of viscosity. Quality requirements are a separate consideration.
- \*Viscosity limits are approximate: For precise data, consult ISO, AGMA and SAE specifications.
- \*W grades define only in terms of 100 C viscosity. For low temperature limits, consult SAE specifications.
- \*ISO = International Standardization Organization
- \*AGMA = American Gear Manufacturers Association
- \*SAE = Society of Automotive Engineers



# **NATIONAL OILWELL VARCO**

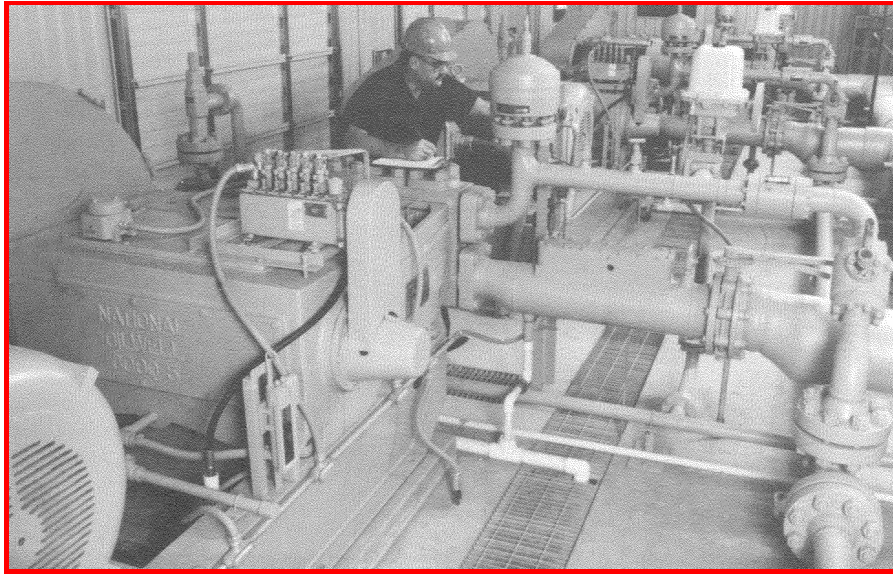

With over 120 locations worldwide, National Oilwell Varco is located near you. To find the nearest Distribution Service Center, machinery center or repair facility, please give us a call at our main office listed below.

Or you can access our website at the URL listed below, where you may search by location or country.

<http://www.natoil.com/locations>

**Sales/Technical Information:**  
**USA Tollfree:** 1 (800) 324-4706

**Internet:** <http://www.natoil.com>

National Oilwell Varco is a leading manufacturer of reciprocating plunger pumps, Mission Fluid King centrifugal pumps, and fluid end replacement parts. We also offer a complete set of solutions to your fluid transfer challenges. For more Information, contact National Oilwell Varco directly at the Headquarters in Houston, Texas. All National Oilwell Varco products are available throughout the U.S. and around the world from service centers, authorized distributors, and representatives.

© Copyright 1999 by National Oilwell, L.P. All Rights Reserved. NATIONAL OILWELL, NATIONAL, and OILWELL are registered trademarks of NATIONAL OILWELL, L.P. Houston, Texas, USA. All other trademarks used are registered to their respective companies. The information and data in this brochure, including but not limited to pictures, photographs, charts, diagrams, drawings, lists, written comments, and specifications, are accurate to the best of our knowledge and belief, but are intended for general information only. Applications suggested for the materials and other information are described only to help readers make their own evaluations and decisions, and are neither guarantees nor are they to be construed as express or implied warranties of suitability for these or other applications. National Oilwell makes no warranty, either express or implied, beyond that stipulated in National Oilwell's Standard Terms and Conditions of Sale which are available upon request.