

Technical Data Sheet

BRANDT™ ALPHA™ Shaker

REFERENCE	REFERENCE DESCRIPTION	
<p>This document contains proprietary and confidential information which belongs to National-Oilwell Varco, L.P., its affiliates or subsidiaries (all collectively referred to hereinafter as "NOV"). It is loaned for limited purposes only and remains the property of NOV. Reproduction, in whole or in part, or use of this design or distribution of this information to others is not permitted without the express written consent of NOV. This document is to be returned to NOV upon request and in any event upon completion of the use for which it was loaned. This document and the information contained and represented herein is the copyrighted property of NOV. © National Oilwell Varco</p>	<p>National Oilwell Varco 2800 N. Frazier Street Conroe, TX 77303 USA Phone +1 936.756.4800 Fax +1 936.523.2788</p>	
DOCUMENT NUMBER 18764755-DAS		REV 01

REVISION HISTORY

Rev	Date (dd.mmm.yyyy)	Reason for issue	Prepared	Checked	Approved
01	09.Feb.2023	Initial Release	PMC	CBT	IMH

TABLE OF CONTENTS

1 ALPHA™ SHAKER SPECIFICATION 4
2 BASKET AND SCREEN DECK..... 5

LIST OF FIGURES

Figure 1-1: Center of Gravity – Shaker 4
Figure 2-1: Center of Gravity – Basket without Motors 5
Figure 2-2: Center of Gravity – Basket with Motors..... 5

LIST OF TABLES

Table 1-1: ALPHA Shaker Specification..... 4
Table 2-1: ALPHA Basket Specification..... 5

1 ALPHA™ SHAKER SPECIFICATION

Nominal technical data for the ALPHA™ Shaker are shown in Table 1-1.

Table 1-1: ALPHA Shaker Specification

Description	US Customary	SI (International System)
Overall Length	120 in	3048 mm
Overall Width	81 5/8 in	2073 mm
Overall Height	65 in	1651 mm
Skid Length	116 in	2946 mm
Skid Width	64 1/16 in	1627 mm
Weir Height	41 3/16 in	1046 mm
Mass (Dry)	5500 lb	2495 kg
Center of Gravity	See Figure 1-1	
X	33 3/4 in	857 mm
Y	24 3/4 in	629 mm
Z	63 3/16 in	1605 mm
Ambient Operating Temperature	-13°F to +104°F	-25°C to +40°C
Voltage/Frequency	3-Phase, 460-480V, 60Hz	
Power Consumption (Max)	5kW per Single Shaker	
G-Force Nominal (Dry)	7+ G	
Motion Type	Linear Motion	
Pneumatic	80 psi to 90 psi	5.51 Bar to 6.2 Bar
Noise Level (at 1 Meter)	-	
A Weighted	69.7 dBA	
C Weighted (Peak)	86.3 dBC	
Certification		
Hazardous Area – North America	Class I, Division 1, Group CD, Temperature Class T4	

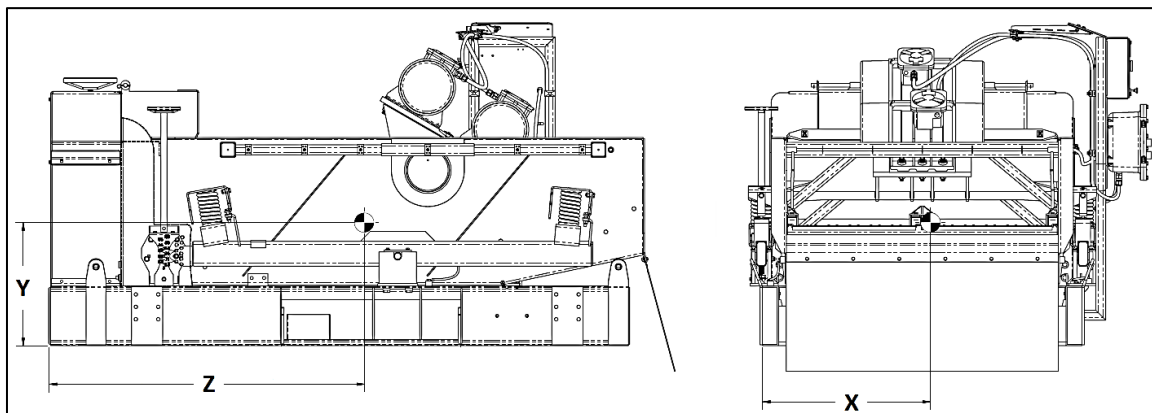

Figure 1-1: Center of Gravity – Shaker

2 BASKET AND SCREEN DECK

Specifications for the ALPHA Shaker basket and screen deck are shown in Table 2-1.

Table 2-1: ALPHA Basket Specification

Description	ALPHA Basket without Motors		ALPHA Basket with Motors	
	US Customary	SI (International System)	US Customary	SI (International System)
Overall Length	100 7/8 in	2562 mm	100 7/8 in	2562 mm
Overall Width	69 7/8 in	1775 mm	69 7/8 in	1775 mm
Overall Height	37-7/8 in	962 mm	47 11/16 in	1211 mm
Mass (Dry)	2340 lb	1061 kg	2940 lb	1334 kg
Center of Gravity	See Figure 2-1		See Figure 2-2	
X	27 9/16 in	700 mm	27 9/16 in	700 mm
Y	14 5/8 in	371 mm	18 13/16 in	478 mm
Z	51 3/4 in	1314 mm	54 in	1372 mm
Basket Angle	Adjustable -2° to +3°			
Number of Screens	6			
Deck Type	+5°			
Deck Area	34.7 ft ²	3.2 m ²	34.7 ft ²	3.2 m ²

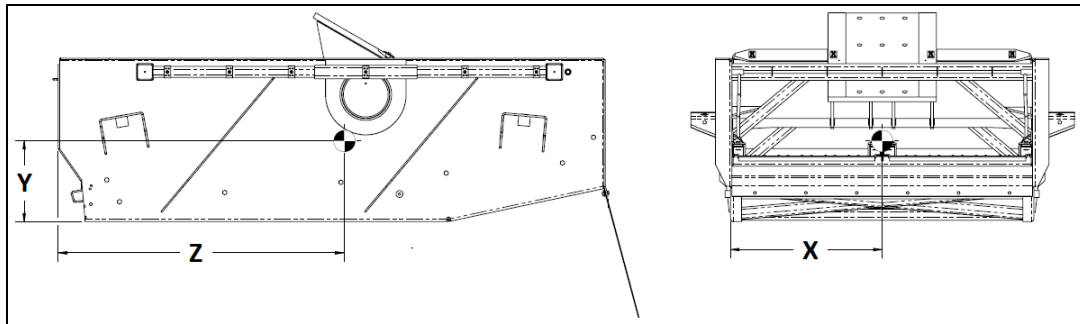

Figure 2-1: Center of Gravity – Basket without Motors

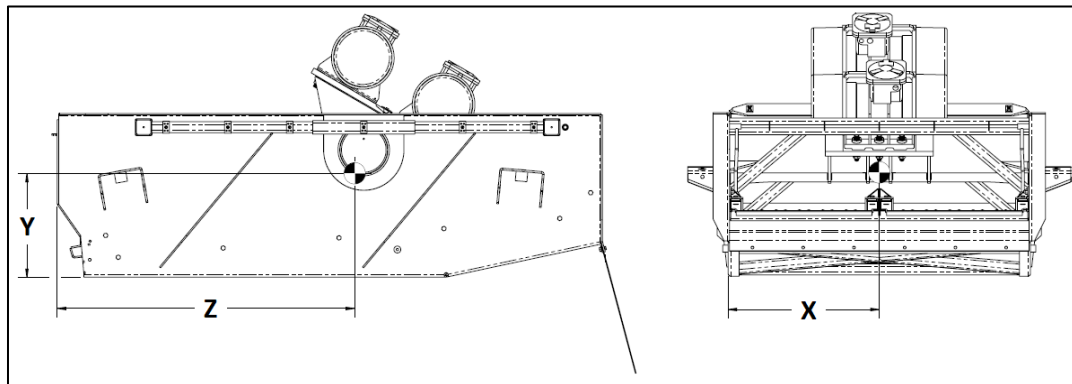

Figure 2-2: Center of Gravity – Basket with Motors