

Installation, Operation and Maintenance Manual

Model 20 GTD, GTP Agitators

Model 20 HTD, HTP Agitators

(Case Size 21, 22, 23)

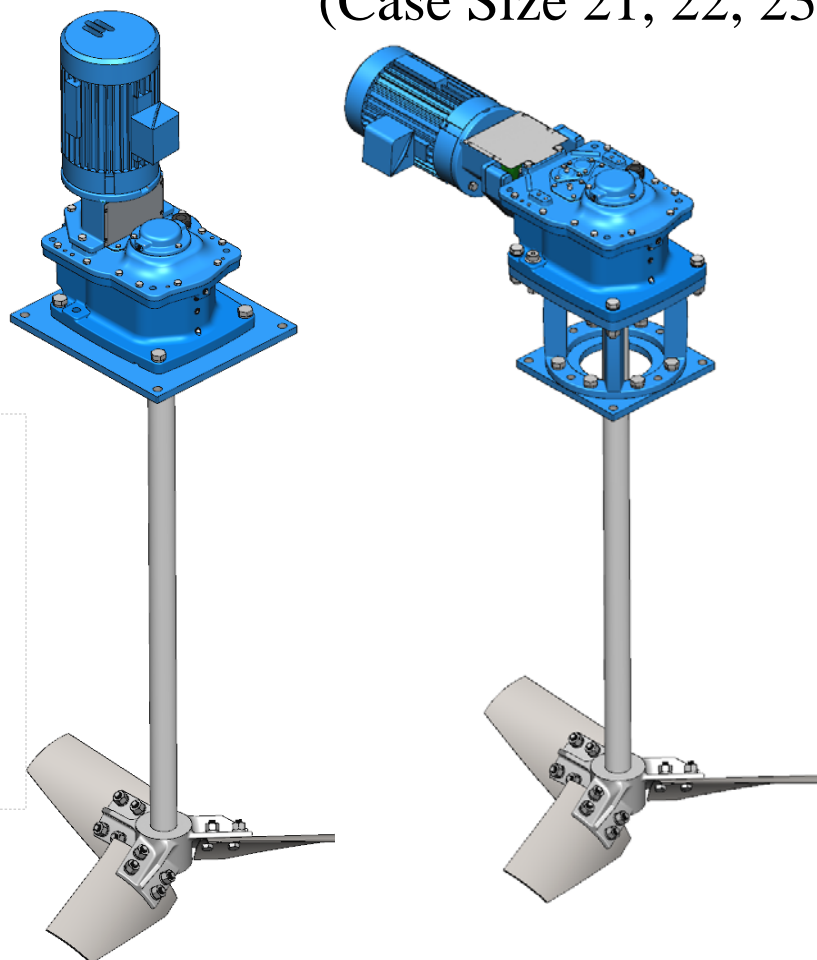

Equipment Reference:

For service and information contact:

Chemineer, Inc.
5870 Poe Ave,
Dayton, OH 45414

Toll Free: 1 (800) 643-0641
Phone: 1 (937) 454 3200
Fax: 1 (937) 454 3379

E-mail: reachus.chemineerus@robn.com
techsales.chemineerus@robn.com
parts.chemineerus@robn.com

Web: www.chemineer.com

Chemineer
7 Cranmer Road
West Meadows
Derby, UK
DE21 6XT

Phone: +44 (0) 1332 363175
Fax: +44 (0) 1332 290323

E-mail: sales.chemineeruk@robn.co.uk
parts.chemineeruk@robn.co.uk

Web: www.chemineer.com

TABLE OF CONTENTS

A. PRODUCT NOMENCLATURE..... 1

B. INITIAL INSPECTION..... 2

C. CHEMINEER ASSISTANCE 3

D. SAFETY..... 4

 D.1 VESSELS..... 4

 D.2 FASTENERS 4

 D.3 CE MARKING (WHERE APPLICABLE) 4

 D.4 SAFETY CHECKLIST 5

E. STORAGE..... 6

 E.1 SHORT-TERM INDOOR STORAGE..... 6

 E.2 OUTDOOR OR LONG-TERM INDOOR STORAGE..... 6

 E.3 CUSTOMER RESPONSIBILITY 8

F. BEAM MOUNTING..... 10

 F.1 DESCRIPTION OF AGITATOR LOADS..... 10

 F.2 STRUCTURAL SUPPORT STEEL DESIGN GUIDELINES 11

G. AGITATOR INSTALLATION..... 17

H. SEAL INSTALLATION - AUXILIARY STUFFING BOX..... 22

 H.1 INTEGRAL-TO-FLANGE STUFFING BOX DESIGN..... 22

 H.2 BOLT-IN STUFFING BOX DESIGN (CAST HOUSING) 24

 H.3 BOLT-IN STUFFING BOX DESIGN (FABRICATED HOUSING)..... 26

I. SEAL INSTALLATION - AUXILIARY LIP SEAL..... 28

J. TAPER BORE COUPLING AND GEAR DRIVE INSTALLATION 30

 J.1 SHAFT TAPER COUPLING INSTALLATION..... 30

 J.2 GEARBOX INSTALLATION 31

K. SHAFT RUNOUT..... 32

L. HANDHOLE COVER INSTALLATION 33

M. MOTOR INSTALLATION..... 34

N. IMPELLERS..... 39

 N.1 MATCH-MARKING..... 39

 N.2 IMPELLERS - INSTALLATION 40

 N.3 IMPELLERS – STYLES 41

N.4	IMPELLERS – COATED / RUBBER COVERED.....	48
O.	OPTIONS	50
O.1	IN-TANK COUPLING.....	50
O.2	STEADY BEARINGS.....	53
O.3	ANCHOR BOLTS	62
P.	LUBRICATION.....	63
P.1	MOTOR - LUBRICATION.....	63
P.2	GEAR DRIVE - LUBRICATION	65
P.3	SHAFT SEALS - LUBRICATION	75
P.4	STEADY BEARINGS - LUBRICATION	75
Q.	OPERATION	76
Q.1	AGITATOR OPERATION	76
Q.2	MOTOR - OPERATION	77
Q.3	FLEXIBLE MOTOR COUPLING.....	78
Q.4	GEAR DRIVE - OPERATION	78
Q.5	SHAFT SEALS - OPERATION.....	79
Q.6	STEADY BEARINGS - OPERATION.....	80
Q.7	TROUBLE-SHOOTING	81
R.	MAINTENANCE –AUXILIARY SEALS	82
R.1	MAINTENANCE – INTEGRAL-TO-FLANGE STUFFING BOX.....	82
R.2	MAINTENANCE – BOLT-ON STUFFING BOX (CAST HOUSING)	84
R.3	MAINTENANCE – BOLT-ON STUFFING BOX (FABRICATED HOUSING) ...	86
R.4	MAINTENANCE – AUXILIARY LIP SEAL	88
R.5	GEAR DRIVE	89
R.6	MAINTENANCE - STEADY BEARING	90
S.	ITEMS LIST.....	93
T.	APPENDIX I	100

LIST OF FIGURES

FIGURE 1A.	MAIN BEAM / GUSSET ORIENTATION	12
FIGURE 1B.	ANGULAR DEFLECTION DIAGRAM	12
FIGURE 2A.	OPEN TANK BEAM MOUNTING – MODEL 20 GTD/HTD	13
FIGURE 2B.	OPEN TANK BEAM MOUNTING – MODEL 20 GTP/HTP	14
FIGURE 4.	MODEL 20 GTD AGITATOR ASSEMBLY	18
FIGURE 5.	MODEL 20 HTD AGITATOR ASSEMBLY	19
FIGURE 6.	MODEL 20 GTP AGITATOR ASSEMBLY	20
FIGURE 7.	MODEL 20 HTP AGITATOR ASSEMBLY	21
FIGURE 8.	AUXILIARY STUFFING BOX.....	23
FIGURE 8A.	AUXILIARY STUFFING BOX (CAST HOUSING).....	25
FIGURE 8B.	AUXILIARY STUFFING BOX (FABRICATED HOUSING).....	27
FIGURE 9.	AUXILIARY LIP SEAL	28
FIGURE 10.	SHAFT COUPLING INSTALLATION.....	30
FIGURE 11.	AGITATOR LIFTING SYSTEM.....	31
FIGURE 12.	HANDHOLE COVER INSTALLATION (CASE SIZES 21 AND 22)	33
FIGURE 13.	HANDHOLE COVER INSTALLATION (CASE SIZE 23)	33
FIGURE 14.	MOTOR COUPLING SETTING	35
FIGURE 15.	MODEL 20 GT – MOTOR MOUNTING.....	36
FIGURE 16.	MODEL 20 HT – MOTOR MOUNTING.....	37
FIGURE 17.	HUB AND PIN KEY DETAIL	40
FIGURE 18.	STYLE P-4 IMPELLER.....	41
FIGURE 19.	STYLE HE-3 IMPELLER.....	42
FIGURE 19A.	STYLE XE-3 IMPELLER.....	43
FIGURE 20.	STYLE S-4 IMPELLER.....	44
FIGURE 21.	STYLE D-6, CD-6, BT-6 IMPELLER.....	45
FIGURE 22.	STYLE SC-3 IMPELLER	46
FIGURE 23.	STYLE MAXFLO W IMPELLER.....	47
FIGURE 24.	THRUST BOLT IMPELLER ATTACHMENT	49
FIGURE 25.	IN-TANK COUPLINGS	51
FIGURE 25A.	IN-TANK COUPLINGS (CONTINUED)	52
FIGURE 26.	BRACKET STEADY BEARING	53
FIGURE 27.	CUP TRI-POD STEADY BEARING	55
FIGURE 27A.	TRIPOD STEADY BEARING.....	58
FIGURE 27B.	PAD STEADY BEARING.....	60
FIGURE 28.	ANCHOR BOLT ASSEMBLY	62
FIGURE 29.	MODEL 20 GT/HT GEAR DRIVE OIL LEVEL DIPSTICK	67
FIGURE 30.	MODEL 20 GT DOUBLE REDUCTION GEAR DRIVE.....	72
FIGURE 31.	MODEL 20 GT TRIPLE REDUCTION GEAR DRIVE	73
FIGURE 32.	MODEL 20 HT GEAR DRIVE.....	74
FIGURE 33A.	AUXILIARY STUFFING BOX.....	83
FIGURE 33.	6 – RING STUFFING BOX (CAST HOUSING)	85
FIGURE 33B.	6 – RING STUFFING BOX (FABRICATED HOUSING)	87
FIGURE 33B.	AUXILIARY LIP SEAL	88

LIST OF TABLES

TABLE 1.	APPROXIMATE STORAGE OIL CAPACITY	9
TABLE 2.	D-STYLE MOUNTING DIMENSIONS	15
TABLE 3.	P-STYLE MOUNTING DIMENSIONS	15
TABLE 4.	RECOMMENDED BEAM SIZES	16
TABLE 5.	MOTOR (NEMA) COUPLING SETTING.....	34
TABLE 6.	MOTOR (IEC) COUPLING SETTING	35
TABLE 7.	TYPICAL NLGI NO. 2 GREASES.....	64
TABLE 8.	MODEL 20 HT INTERMEDIATE BEARING GREASE ADDITION	66
TABLE 9.	LUBE OIL SELECTION.....	68
TABLE 10.	APPROXIMATE OPERATING OIL CAPACITY	68
TABLE 11.	TYPICAL RUST & OXIDATION INHIBITED (R&O) LUBE OILS	69
TABLE 12.	TYPICAL EXTREME PRESSURE (EP) LUBE OILS	70
TABLE 13.	TYPICAL SYNTHETIC LUBE OILS	71
TABLE 14.	TROUBLE-SHOOTING GUIDE.....	81
TABLE 15.	BRACKET, TRIPOD AND PAD STEADY BEARING WEAR SLEEVE AND BUSHING WEAR ALLOWANCES	90
TABLE 16.	CUP TRIPOD STEADY BEARING WEAR SLEEVE AND BUSHING WEAR ALLOWANCES	91
TABLE 17.	BOLT TIGHTENING TORQUE	100
TABLE 18.	BOLT TIGHTENING TORQUE (CONTD).....	101
TABLE 19.	BOLT GRADES AND MECHANICAL PROPERTIES	102

A. PRODUCT NOMENCLATURE

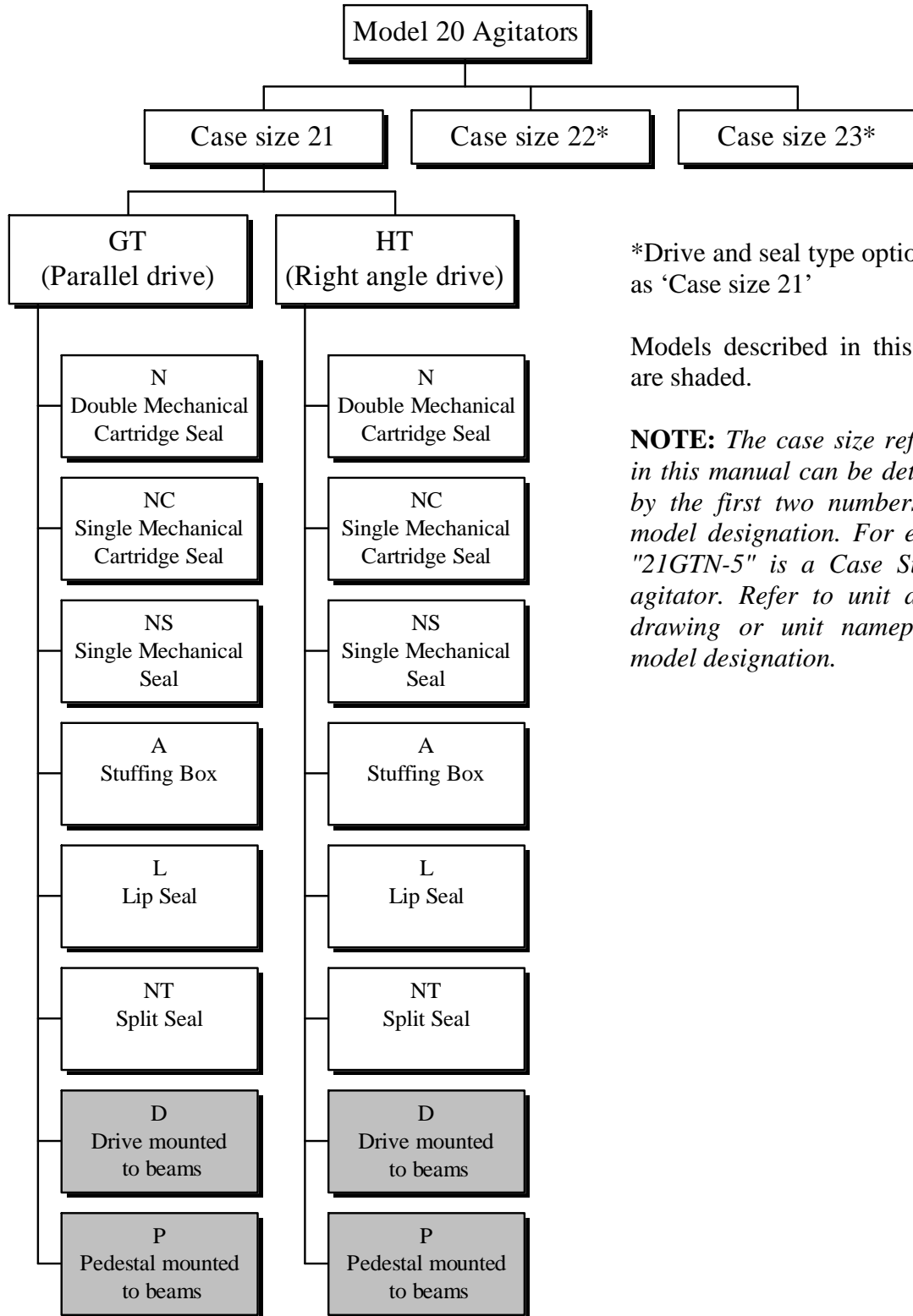

*Drive and seal type options same as 'Case size 21'

Models described in this manual are shaded.

NOTE: The case size referred to in this manual can be determined by the first two numbers in the model designation. For example: "21GTN-5" is a Case Size "21" agitator. Refer to unit assembly drawing or unit nameplate for model designation.

B. INITIAL INSPECTION

Step 1: Inspect crates. Upon receipt, inspect all crates and equipment for any damage during shipping. If you observe any damage, please report it to your [local Chemineer office](#) or to the factory of origin. A claim should be filed immediately with the carrier involved.

Step 2: Uncrate. Check the contents. Do not un-crate the unit until you have read all the Installation instructions and viewed the assembly drawing shipped with the unit. Be careful in uncrating and handling. Before discarding the crating, make sure that all agitator parts have been removed. Correct assembly of this unit requires referring to both the unit assembly drawing and this manual.

Step 3: Questions? Call Chemineer. If the shipment is not complete or you do not understand what you have received, please contact your [local Chemineer office](#) immediately.

C. CHEMINEER ASSISTANCE

Chemineer maintains a fully staffed Parts and Field Service Department ready to help you with any service requirement. When in doubt contact your local Chemineer office, or Parts/Field Service department at the Chemineer Factory:

USA

Chemineer, Inc.
5870 Poe Ave,
Dayton, OH 45414

Phone: +1 (937) 454 3200
Toll Free: 1 800 643-0641
Fax: +1 (937) 454 3379

UK

Chemineer
7 Cranmer Road
West Meadows
Derby, UK
DE21 6XT

Phone: +44 (0) 1332 363175
Fax: +44 (0) 1332 290323

For your convenience, Chemineer offers the following services:

- Installation and maintenance training seminars
- Installation and start-up supervision
- Preventative maintenance planning
- Parts order service

D. SAFETY



D.1 VESSELS

All types of vessels either open or closed pose special safety challenges. It is essential that Installers, Operators and Maintainers of the equipment understand these special hazards.

Particular safety hazards arise because the vessel is typically defined as a “Confined Space”. This creates a number of special hazards, including the risk of having oxygen shortages. Never enter a confined space unless you are fully trained on the procedures and have the correct safety equipment and procedures in place.

One must not enter a confined space unless fully assured that it is safe. Typically, before entering a vessel you should require proof of power and process fluid lock out. Always carry with you an oxygen sensor (in order to verify a safe atmosphere), a suitable safety harnesses and lifting equipment. Typically, a shoulder lift harness and a man-lifting crane are required (a man on the end of a rope or a center back lift offers no safety protection). A suitable safety cover must be provided at all time.

In cases where a vessel has been in service, tests must be made to ensure that no hazardous products or product residues are present.

The work site is often within a designated hazardous area. Where potentially explosive conditions exist, all efforts must be made to make the area safe before proceeding with work. Where this is not possible, a detailed, individual hazard assessment is vital. Special working procedures and tooling are required.

D.2 FASTENERS

Critical fasteners should not be reused. Critical fasteners are those that are used with torque control, for example blade bolts, shaft coupling bolts, pedestal fixing bolts, etc. When a fastener is disturbed, always replace it with a new one. Dispose of used fasteners.

D.3 CE MARKING (WHERE APPLICABLE)

Any CE marking and associated documentation applies to the mixer only on the basis that it is an individual product. After installation of the mixer into the mixing system, it becomes an integral part of a larger installation. **Chemineer is not responsible for the CE marking once the mixer has been installed into the mixing system.**

D.4 SAFETY CHECKLIST

- ☑ This Installation, Operation and Maintenance Manual, assembly drawings, and any supplements must be reviewed and understood before commencing installation and operation.
- ☑ All site rules must be observed for the installation and operation of this mixer.
- ☑ Ensure all external connections are made in accordance with applicable codes of practice.
- ☑ The mixer must be earthed (connected to ground).
- ☑ Correct rotation must be checked prior to operation.
- ☑ **Do not** exceed the operating pressures, temperatures, and other conditions for which the machine has been designed.
- ☑ **Do not** operate the agitator unless all guards are securely fixed. Do not modify any guarding. Open tanks fitted with agitators must be provided with suitable guarding to prevent personnel contacting agitator-moving parts. The user is responsible for providing these guards.
- ☑ Ensure mechanical seal setting clips are disengaged before operation. These clips should be retained for future use.
- ☑ Ensure gas supply system, (if applicable) is correctly installed, pressurized and ready for operation.
- ☑ **Do not** touch rotating components.
- ☑ During servicing of the mixer, the motor must be isolated from the power supply and the supply locked out.
- ☑ **Do not** operate the mixer for applications other than for its intended use.
- ☑ **Do not** modify the mixer without reviewing the change with Chemineer. It is unsafe to use non-standard parts without Chemineer's approval. When in doubt, ask your local Chemineer office.

WHEN IN DOUBT, ASK!

E. STORAGE

Do not remove protective packaging, desiccant, or any protective coatings applied to the wetted parts until the agitator is to be put into service. If the equipment is to be stored, do not stack crates. Store in a clean dry indoor location, which is free from wide variations in temperature. The storage area should be free from vibration and excessive heat.

Inspect for external rust at three-month intervals. Apply a rust preventative to unpainted carbon steel surfaces to prevent corrosion during storage. If the unit has been in storage for more than three months or subjected to adverse moisture conditions, the motor windings may have to be dried prior to operation.

E.1 SHORT-TERM INDOOR STORAGE

Agitators should be stored indoors in areas with no vibration and relatively constant temperatures and humidity. The factory storage preparations should be acceptable for up to six months storage. If the storage period will exceed six months, see the Long-Term Indoor Storage section.

E.2 OUTDOOR OR LONG-TERM INDOOR STORAGE

Storage of agitators and motors outdoors is not recommended. Unless specially prepared, our equipment is supplied with the intent that it will be immediately installed and commissioned or subject to short-term indoor storage only.

Equipment subject to long-term storage can suffer extensive damage due to corrosion. Unlike during operation, during storage the gearbox surfaces are not covered with oil and the moisture due to condensation inside the gearbox does not evaporate. This can rapidly lead to severe rust of the precision components causing extensive damage.

The method employed for long-term storage is to prevent the humidity/temperature changes and airborne chemicals from making contact with the internal components of the equipment. The methods described below provide protection but cannot avoid some level of degradation of the equipment.

E.2.1 To prevent from corrosion:

Oil Flooding

Filling the gearbox completely with oil and then sealing it off provides excellent protection against the environment. Refer to Table 1, page 9. This will ensure that all the internals are covered and thus protected against corrosion. Note that when this is done, oil enters the dry well area so the gearbox will need to be turned upside down to fully drain it at the end of the storage period. Motor engine oils contain higher levels of corrosion inhibitors than most industrial gear oils and so can be a good choice. However, these engine oils may not be suitable for use in the mechanical seal. Always use new oil. It is recommended that a new charge of grease be added to the lower bearing after a short time of operation due to the oil being in contact with this grease during the storage period.

Extremes temperatures can cause the oil volume to change. To prevent oil leakage through the seals, it is recommended to reduce the oil capacity if it is known the temperature will vary greatly throughout the storage period.

Vapor Phase Inhibitor (VPI)

VPI as an additive to oil can provide excellent protection against corrosion. For maximum benefit, it is used in conjunction with desiccant bags. Typically, the desiccant bags should be changed periodically as the environmental humidity dictates. Follow the product manufacturers instructions. It is essential to seal up the gearbox as much as possible and to take all reasonable steps to protect against temperature fluctuation and excess moisture.

Inert Gas Purging

Any inert environment provides excellent protection of the equipment for an indefinite period. Nitrogen is one inert gas usually available at any refinery or chemical plant. Nitrogen also absorbs humidity when it is dry and carries it away when permitted to flow.

- Completely drain the oil from the gearbox
- Install a nitrogen supply line and vent to each subassembly. Typically to the gearbox breather port and the mechanical seal barrier fluid inlet port.
- Install a vent plug in a port farthest from the Nitrogen inlet. Typically, at the oil drain fitting in the gearbox /seal. This plug must have a 1/8" / 3 mm diameter hole drilled through to allow the gas to vent.
- Oil may be left in any external lube oil piping.
- Grease the input shaft and coupling areas with rust preventative grease and wrap the greased area with waterproof barrier paper.
- Pressurize the gas purge system. Store on an elevated surface.

NOTE: The pressure in the gearbox must not exceed 5 psig. Allow the gas to flow through for several minutes by releasing the vent plug. Then adjust the gas flow rate to a minimum of 1 cubic foot per hour (0.5 litre / min).

- Completely enclose the entire unit with a heavy plastic, tarpaulin, or similar type of protective cloth. Do not allow the weight of the covering to be carried by any instrumentation.
- Place a few desiccant bags inside the covering. Allow the nitrogen to leak out from underneath the covering.



CAUTION! Nitrogen gas can be a hazard. Ensure that suitable safety precautions are in place.

E.2.2 To protect elastomers:

Elastomers will age, can stick or take set. In order to prevent the elastomers from sticking, regularly rotate shafts in order to redistribute lubricants. Protect the equipment from direct sunlight and from ozone to minimize the rate of aging of the elastomers.

E.2.3 To avoid false brinelling:

Rotate the motor and gear drive shafts 10 to 15 revolutions at least once per month to reduce the possibility of false brinelling of the bearings and to re-distribute bearing grease.

Other problems include vibration related damage. Do not store equipment in a manner that subjects it to vibration.

Motor space heaters, if installed, should be energized during the storage period.

Note: When the equipment is to be stored in a strong chemical environment or near salt-water, protection procedures should be executed immediately upon receipt of the equipment.

E.3 CUSTOMER RESPONSIBILITY

To ensure the original quality of the Chemineer equipment prior to commissioning after storage, all components must be inspected by an authorized Chemineer Service Engineer. Any sub assemblies not manufactured by Chemineer must be inspected by that part supplier/manufacturer's authorized service personnel. Chemineer is not responsible for the cost of such a service.

Because of storage location and other unknown site factors are beyond Chemineer's control, Chemineer will not accept any liability for damage to the equipment during the storage period.

Table 1. APPROXIMATE STORAGE OIL CAPACITY

MODEL	TYPE	QUARTS (US)	GALLONS (US)	LITRES
21	GT	5.6	1.4	5.3
	HT	5.6	1.4	5.3
22	GT	11	2.75	10.4
	HT	11	2.75	10.4
23	GT	25	6.25	23.6
	HT	25	6.25	23.6



CAUTION! Before placing an agitator into service, the storage oil must be completely drained from the gear drive. **Turn the gear drive upside down to completely drain.** Failure to do this will result in oil being trapped in the "drywell" around the output shaft and could result in leakage at the output shaft seal. The gear drive should be filled with new oil and re-greased as indicated in the [Lubrication](#) section of this manual.

F. BEAM MOUNTING

Model 20 GTD, GTP, HTD and HTP (open tank) style units usually mount separately from the tank on either a steel structure or a concrete slab over the tank. D style units may include an auxiliary shaft seal as an option. Refer to the agitator assembly drawing for minimum required mounting height to allow for servicing the seal.

The most frequent cause of mechanical difficulty with an agitator is improper mounting. It is imperative to heed the following guidelines:

1. The agitator extension shaft is designed to run in a true vertical position.
2. Do not angle or side mount the agitator unless it was specifically designed for angle mounting by Chemineer.
3. Do not mount on a surface that is not flat and horizontal.
4. Start up of the agitator with the turbine impacted in solids is beyond the scope of these recommendations.
5. The mounting structure must be rigid enough to meet the requirements described in section F.1 and F.2 below.

F.1 DESCRIPTION OF AGITATOR LOADS

During operation of the agitator, the fluid motion in the vessel produced by the rotation of the turbine impeller can exert significant forces and moments on the agitator extension shaft. The forces and moments produced by the turbine rotating in a fluid are; torque, turbine thrust (up or down) and turbine hydraulic (side) force.

The hydraulic forces acting on the turbine generate moments, which act on the shaft and are transmitted to the agitator drive. Because of the random nature of the forces and the rotation of the shaft, the direction of these forces is constantly changing.

A pitched blade or axial flow turbine will impart an upward or downward thrust depending on if it is a down or up pumping turbine, respectively. The thrust force is generally less than the weight of the unit.

The agitator has been designed to accommodate all of the forces mentioned, and as a result, the forces are transmitted directly to the mounting support. The support structure must be rigid enough to support the agitator weight and the live agitator reactions resulting from the torque, thrust and bending moment. The structure should be sufficiently rigid that, *assuming a perfectly rigid agitator extension shaft*, the structure deflection will not cause the impeller end of the shaft to deflect more than 2.6 mm per meter of shaft length. See Figure 1B on page 12.

Particular attention should be given to reducing the torsion of the support beams local to the agitator mounting in both the X and Y directions. Lateral beams adjacent to the agitator mount should be sized the same as the longitudinal spans. Gussets of sufficient thickness should be used on the beam structure under the agitator mounting plate to insure full load transfer from the agitator mount to the support structure. See Figure 1A on page 12.

F.2 STRUCTURAL SUPPORT STEEL DESIGN GUIDELINES

The following Design Guidelines should be followed while designing the support structure:

1. The minimum natural flexural frequency of the agitator support structure should be at least five times the maximum impeller rpm.
2. All structural steel should be fabricated and erected in strict accordance with the latest A.I.S.C. specifications unless local code supersedes this specification.
3. Unless otherwise noted, all structural steel shapes and plates should conform to ASTM A529; structural tubing should be ASTM A500, Grade B.
4. Unless otherwise noted, all bolted connections should be designed as bearing type connections.
5. All bolts shall be tightened to within 70% of their minimum tensile strength.
6. Unless the process conditions, environmental conditions, or local codes prohibit, all bolting shall be galvanized or zinc plated carbon steel.

See Table 4, page 16, for recommended beam sizes. Values in this table are keyed to the gearbox model, case size, and tank diameter. Select the appropriate beam size for your application. Beams of equivalent, or greater, section modulus and moment of inertia and/or modulus of elasticity can be used. See Figure 2A, page 13 for D style or, Figure 2B, page 14 for P style.

THIS INFORMATION IS INTENDED AS A GUIDE, AND DOES NOT RELIEVE THE USER OF COMPLETELY ANALYZING THE ENTIRE MOUNTING SYSTEM. EXTREME APPLICATIONS OR DESIGNS MAY REQUIRE SUPPORT STIFFNESS GREATER THAN THE RECOMMENDATIONS PROVIDED HEREIN. CONSULT *CHEMINEER INSIDE SALES* FOR DESIGN GUIDANCE.

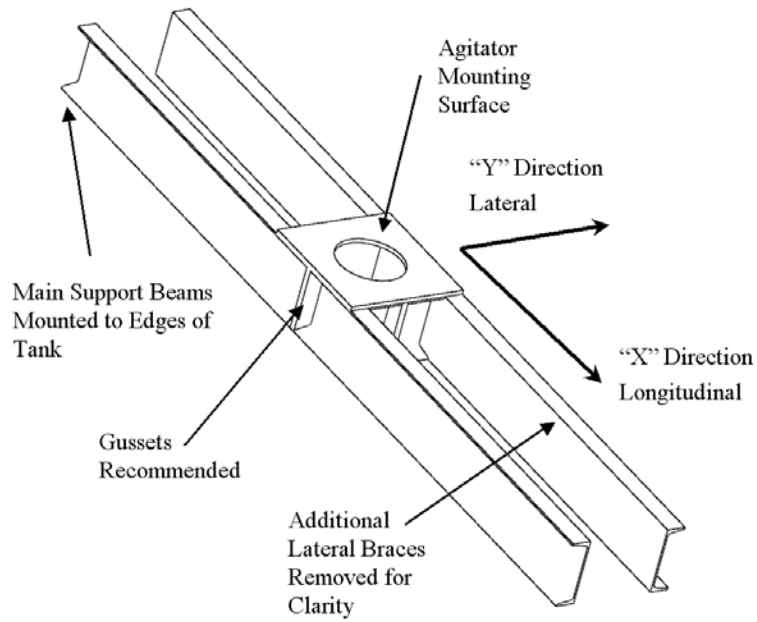

Figure 1A. Main Beam / Gusset Orientation

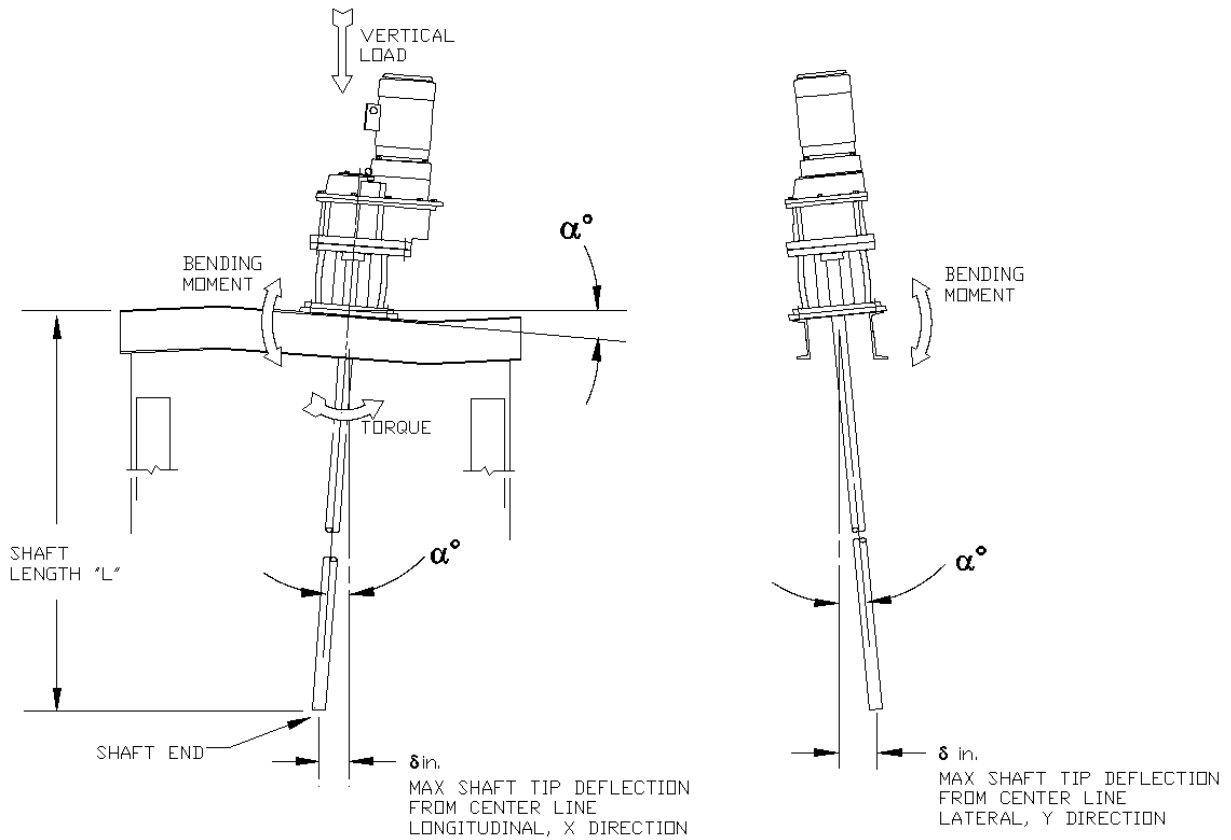

Figure 1B. Angular Deflection Diagram

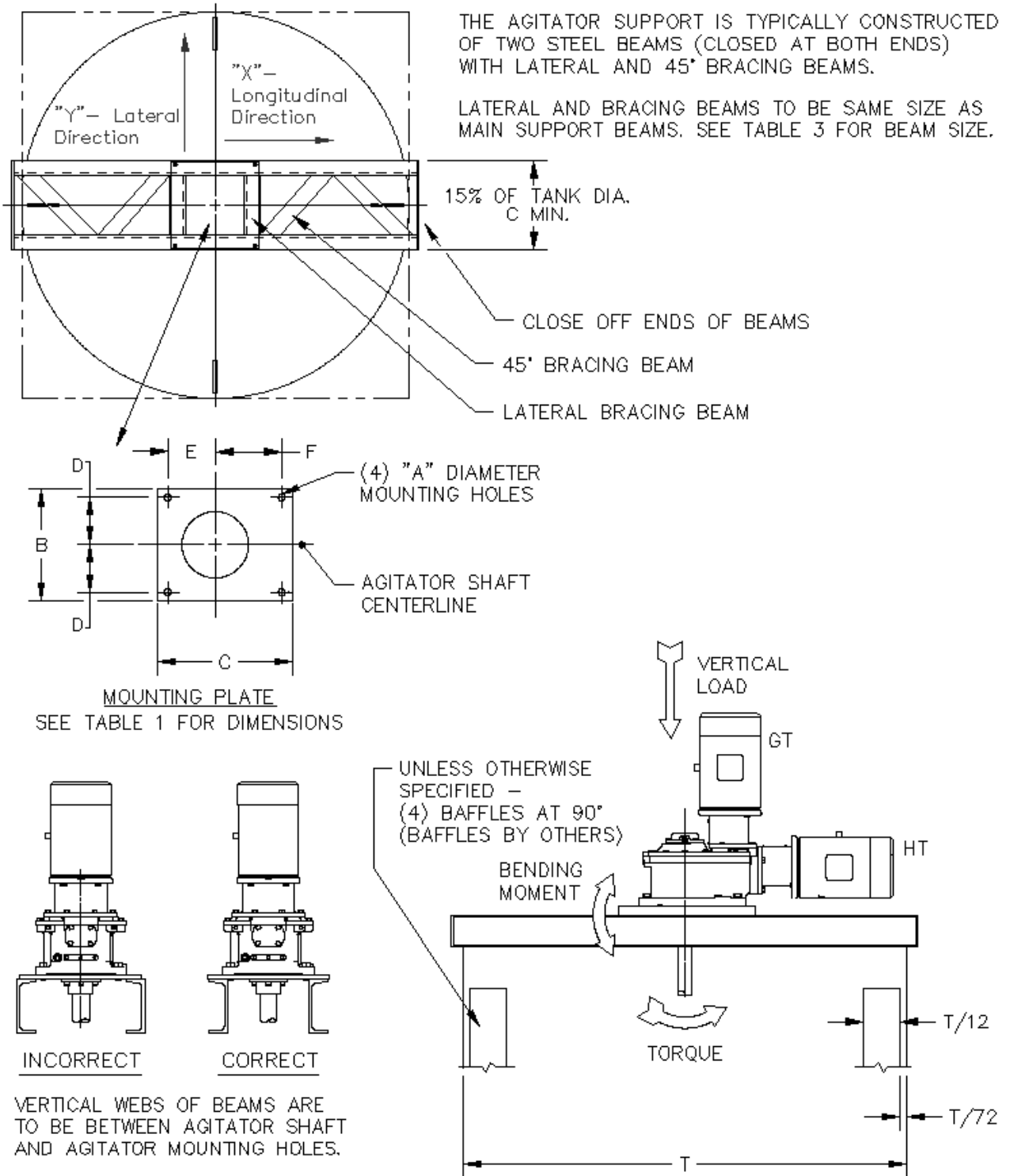
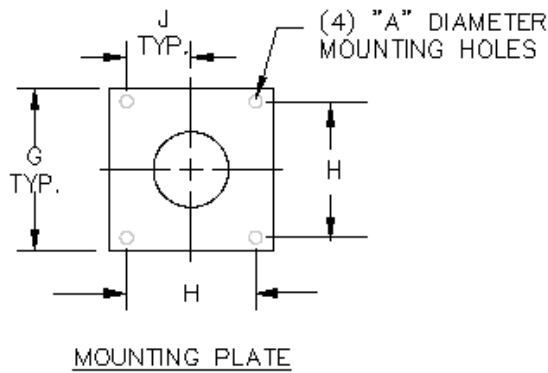
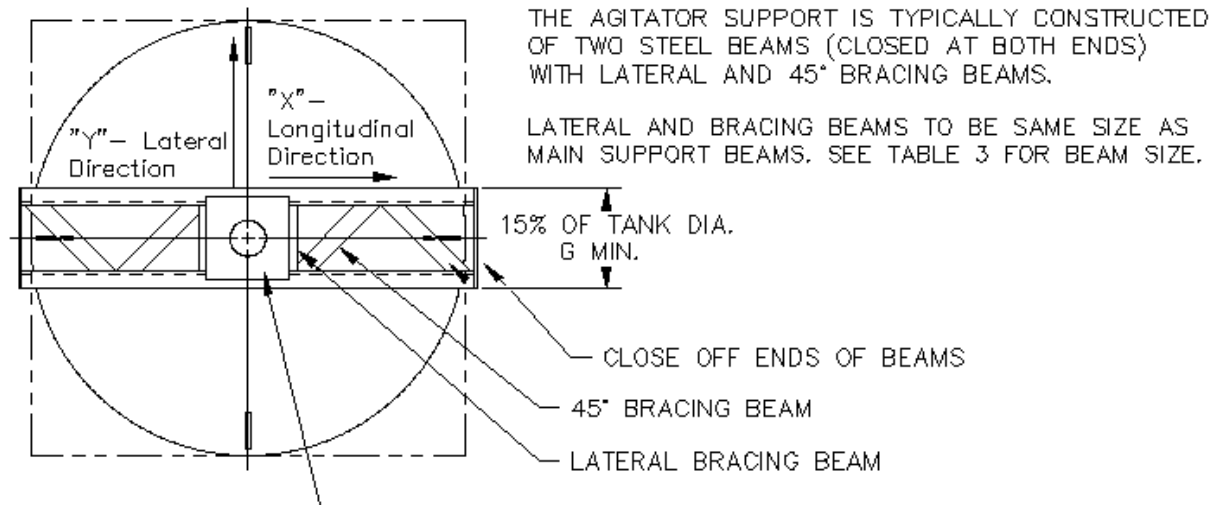
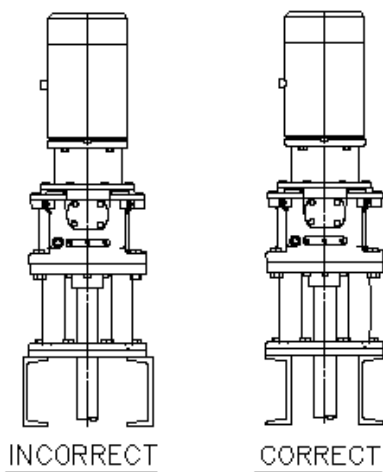

Figure 2A. Open Tank Beam Mounting – Model 20 GTD/HTD



SEE TABLE 3 FOR MOUNTING DIMENSIONS



VERTICAL WEBS OF BEAMS ARE TO BE BETWEEN AGITATOR SHAFT AND AGITATOR MOUNTING HOLES.

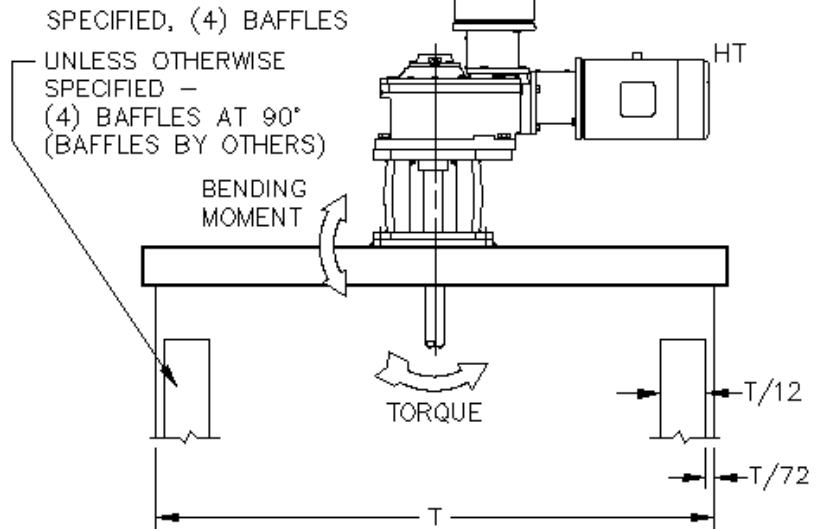

Figure 2B. Open Tank Beam Mounting – Model 20 GTP/HTP

Table 2. D-STYLE MOUNTING DIMENSIONS

CASE SIZE	A	B	C	D	E	F
Model 21	0.88" (22.2 mm)	18.00" (457 mm)	20.00" (508 mm)	8.00" (203.2 mm)	8.00" (203.2 mm)	10.00" (254 mm)
Model 22	1.00" (25.4 mm)	22.50" (584 mm)	25.00" (635 mm)	10.00" (260.4 mm)	9.75" (247.7 mm)	12.75" (323.9 mm)
Model 23	1.00" (25.4 mm)	28.00" (711.2 mm)	19.50" (495.3 mm)	12.75" (323.9 mm)	10.75" (273.1 mm)	6.25" (158.8 mm)

Table 3. P-STYLE MOUNTING DIMENSIONS

CASE SIZE	A	G	H	J
Model 21	0.88" (22.2 mm)	13.50" (342.9 mm)	11.75" (298.5 mm)	5.88" (149.2 mm)
Model 22	1.00" (25.4 mm)	16.00" (406.4 mm)	14.00" (355.6 mm)	7.00" (177.8 mm)
Model 23	1.00" (25.4 mm)	16.00" (406.4 mm)	14.00" (355.6 mm)	7.00" (177.8 mm)

Table 4. RECOMMENDED BEAM SIZES

CASE SIZE	TANK DIAMETER Ft (m)						
	4 (1.22)	6 (1.83)	8 (2.44)	10 (3.05)	15 (4.57)	20 (6.10)	25 (7.62)
21 GT/HT	C5 X 6.7	C6 X 8.2	C7 X 9.8	C8 X 11.5	C12 X 20.7	C15 X 33.9	C15 X 50
22 GT/HT	*	C7 X 9.8	C8 X 11.5	C12 X 20.7	C15 X 33.9	MC18 X 42.7	*
23 GT/HT	*	W8 X 10	W10 X 12	W12 X 16	W16 X 31	*	*

* Consult Factory

C = American Standard Channel

MC = American Standard

Miscellaneous Channel

American Std. Channel	Channel to BS4 Pt.1
C4 x 5.4	102 x 51 10.42 kg/m
C5 x 6.7	127 x 64 14.9 kg/m
C6 x 8.2	127 x 64 14.9 kg/m
C7 x 9.8	152 x 76 17.88 kg/m
C8 x 11.5	152 x 89 23.84 kg/m
C9 x 15	178 x 89 26.81 kg/m
C12 x 20.7	254 x 89 35.74 kg/m
C15 x 33.9	381 x 102 55.1 kg/m
C15 x 50	432 x 102 65.54 kg/m

G. AGITATOR INSTALLATION

Correct installation requires both the unit assembly drawing and this manual.

Note: These instructions deal with the highest level of details required to assemble the entire unit. However, the specific unit supplied to you may have some assembly steps completed. Use discretion and omit these steps

1. The agitator is shipped in various crates: one for the agitator gear drive [200], one for the shaft and impeller [500] and typically one for the motor [100]. Optional accessories, multiple shafts, or multiple impellers may be crated separately.



CAUTION! *Coated/rubber covered agitator parts require special handling to avoid damage to coatings/rubber coverings. Do not use chains or hooks on coated/covered surfaces. Special care is required to prevent damage to edges and outside corners. Special installation procedures are required for large one-piece impeller/extension shaft assemblies. Contact Chemineer Field Service for instructions.*

2. Remove all shipping restraints. A hoist or crane system for the lifting of the agitator parts must be available. Refer to Figure 11, page 31 for lifting instructions. The approximate net weight of the unit is shown on the unit assembly drawing. Since gear drives are typically supplied with the motor un-mounted, always verify that the motor being mounted is correct for the gear drive by checking the assembly drawing.
3. For GTP/HTP style units, install handhole cover bolts, lockwashers [1106, 1107] into the pedestal [1101]. Refer to Section A, page 33. Torque bolts to value shown in the APPENDIX, Page 100.
4. Install gear drive support pedestal assembly (GTP/HTP) or just the gearbox (GTD/HTD) to mounting structure. Install mounting bolts (supplied by others) and torque to the value shown in the APPENDIX, Page 100.

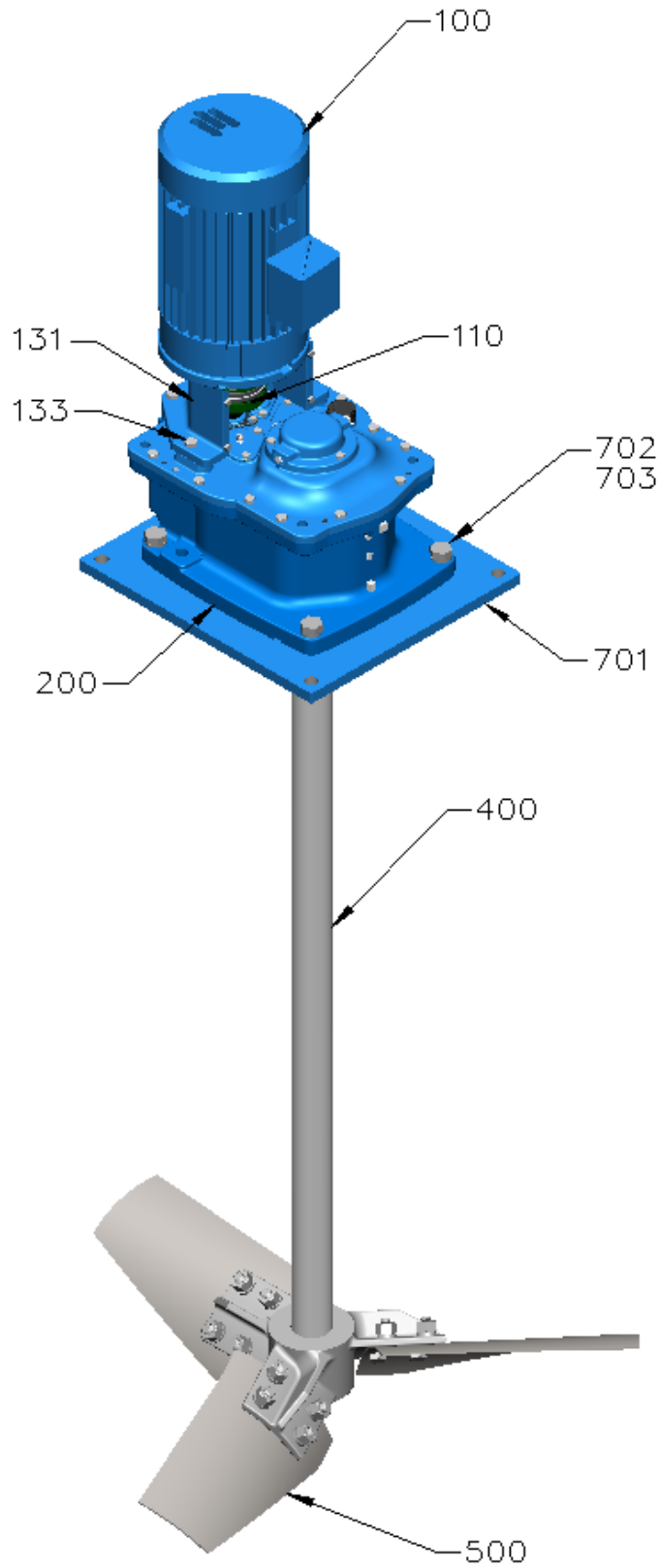

Figure 4. Model 20 GTD Agitator Assembly

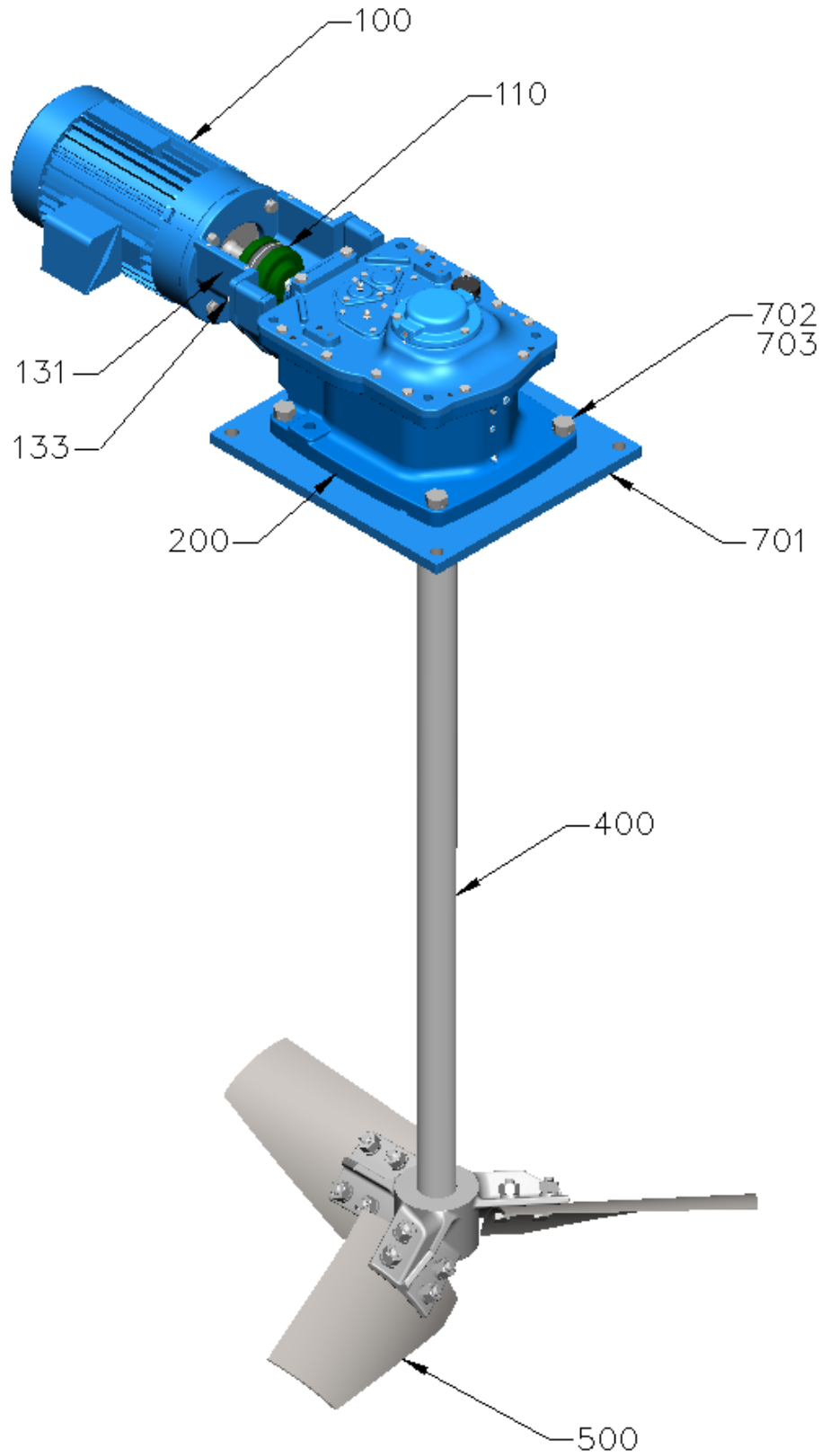

Figure 5. Model 20 HTD Agitator Assembly

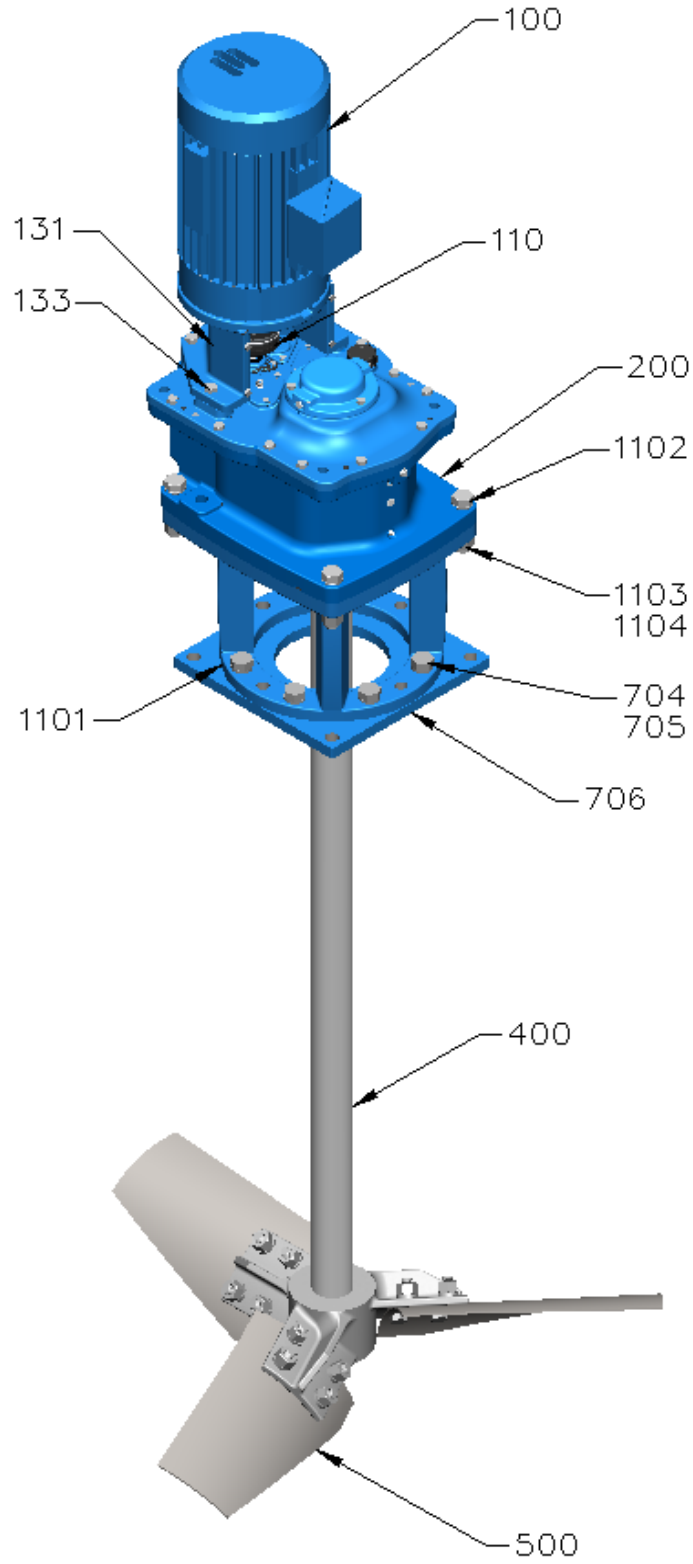

Figure 6. Model 20 GTP Agitator Assembly

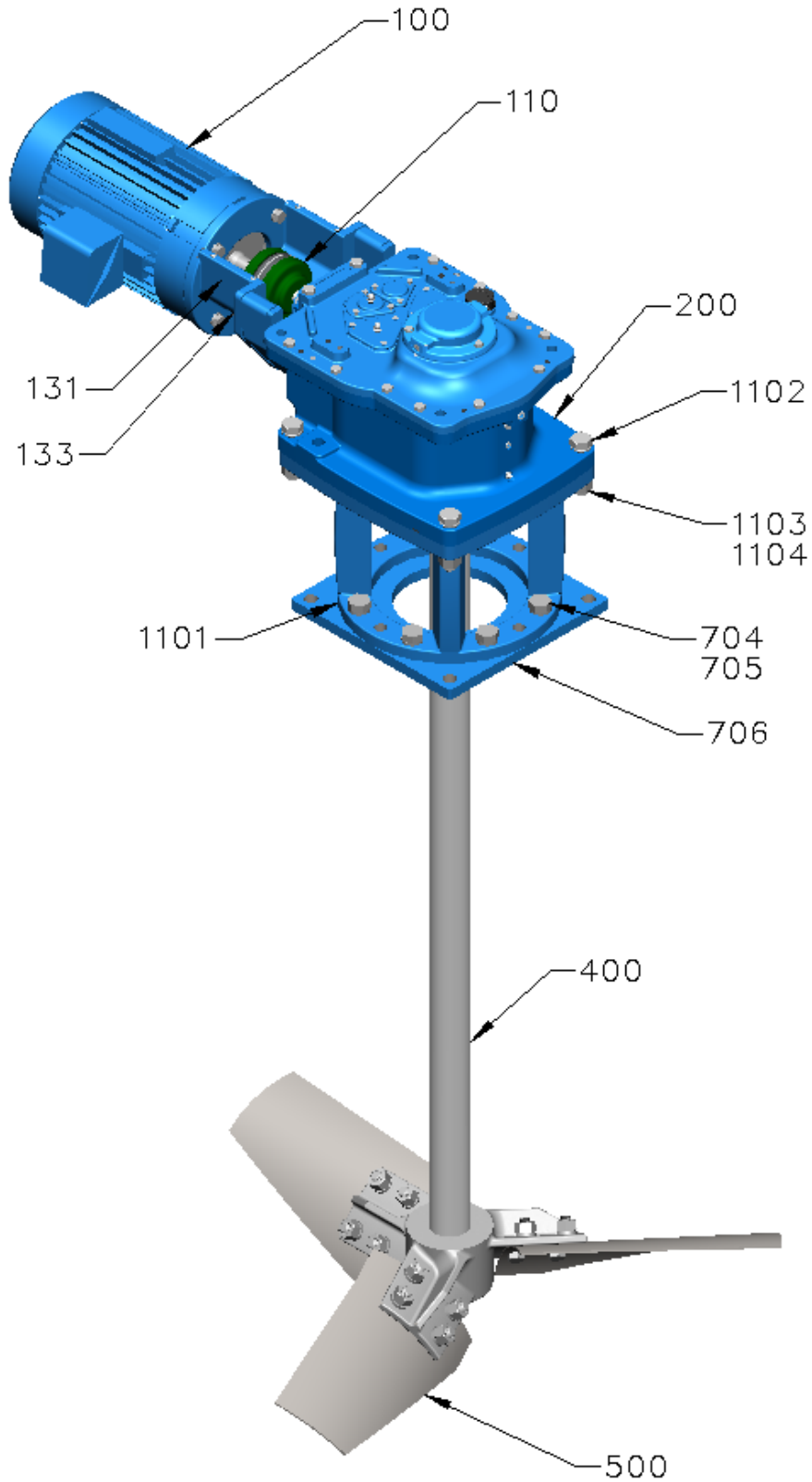

Figure 7. Model 20 HTP Agitator Assembly

H. SEAL INSTALLATION - AUXILIARY STUFFING BOX

Applicable to: Model 20GTD (w/Auxiliary Seal) and Model 20 HTD (w/Auxiliary Seal). Examine Figure 8, Figure 8A and Figure 8B to determine which type of stuffing box was supplied with your unit.

H.1 INTEGRAL-TO-FLANGE STUFFING BOX DESIGN

1. Remove gland plate [1355], split gland [1356], packing [1357] and lantern ring [1358].
2. Assemble the auxiliary stuffing box flange to the vessel with the proper gasket and bolts (supplied by others). *Do not install the bolts at this time.*
3. Place packing [1357], lantern ring [1358] and gland plate [1355] over the extension shaft and lower the extension shaft into the vessel through the auxiliary stuffing box flange.
4. If the extension shaft coupling half is not installed, the shaft may be lifted up through the auxiliary stuffing box from inside the vessel. Block the shaft from inside the vessel such that the extension shaft extends above the agitator drive mounting surface. Install packing, lantern ring and gland plate over the extension shaft.
5. Install the extension shaft coupling half if required. Follow instructions in Section J, page 30 in order to install the gearbox and taper bore coupling.
6. Install the auxiliary stuffing box flange bolts finger tight. If the bolt holes in the stuffing box flange and the vessel flange are not properly aligned, the agitator drive will have to be moved laterally or shimmed. If shimming is required, use full width shims under the gear drive mounting surface to provide a solid joint for bolting the agitator drive to the support structure.
7. Tape gland plate [1355] to the extension shaft coupling half. Attach an indicator to the extension shaft and set the point of the indicator on the top face of the stuffing box housing. Manually turn the flexible motor coupling to rotate extension shaft one turn. Shim the agitator drive until the indicator reading is within .005" (.127mm) FIM (Full Indicator Movement) maximum. Torque agitator mounting bolts to value shown in APPENDIX, Page 100
8. In extreme cases, a tapered adapter will be required (supplied by others) to correct the angular misalignment. Call Chemineer Field Service for assistance.
9. Attach an indicator to the extension shaft and set the point of the indicator on the inside diameter of the stuffing box housing. Align the stuffing box housing to within .005" (0.127 mm) FIM of the shaft centerline and then tighten the stuffing box flange bolts (supplied by others). Torque to the value shown in APPENDIX, Page 100.

10. Install packing, lantern ring, split gland, and gland plate [1357, 1358, 1356, 1355]. Install gland nuts and lockwashers [1353, 1354]. Finger tighten hex adjusting nuts [1352].
11. Let the packing set for five to ten minutes so that it can cold flow and adjust to the gland pressure. Loosen the hex adjusting nuts, then finger tighten. After starting the unit, the packing will require adjusting. Refer to SHAFT SEALS - OPERATION.
12. Continue with the agitator installation.

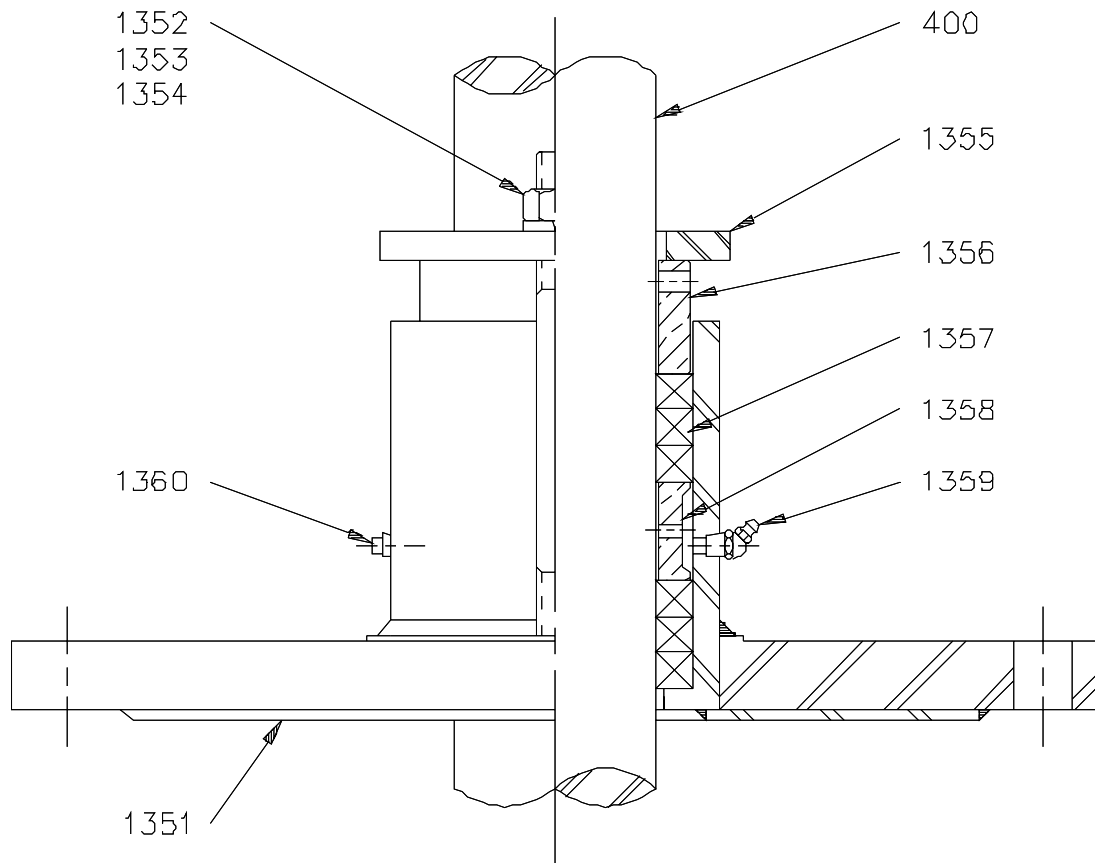

Figure 8. Auxiliary Stuffing Box

H.2 BOLT-IN STUFFING BOX DESIGN (CAST HOUSING)

1. Assemble the flange [1251] to the vessel with the proper gasket and bolts (supplied by others).
2. If a removable coupling is supplied with the unit, lift the agitator extension shaft and lower it into the vessel. Lift the shaft up through the mounting flange from inside the vessel and block it in place such that the shaft extends above the gearbox mounting surface. If a welded or shrink fit coupling is already assembled onto the shaft, the shaft will need to be lowered down into the flange and blocked in place in this manner.
3. Place o-ring [1252] into the groove in the mounting flange [1251].
4. Install the packing housing [1314] and packing rings [1313]. Stagger each packing split by 90° during installation. Seat each packing ring one at a time as it is installed.
5. Install the two threaded studs [1305] at 180° from each other.
6. Install nuts, lockwasher and flatwasher [1306, 1307, 1308] onto studs. *Do not tighten at this time.*
7. Install two bolts, lockwashers and flatwashers [1309, 1310, 1311]. *Do not tighten at this time.*
8. Install the extension shaft removable coupling (if applicable). Follow instructions in Section J, page 30, in order to install the gearbox and taper bore coupling.
9. Attach an indicator to the extension shaft and set the point of the indicator on the inside diameter of the stuffing box housing. Align the stuffing box housing to within .005" (0.127 mm) FIM of the shaft centerline and then tighten bolts [1309] and nuts [1306]. Torque to the value shown in APPENDIX, Page 100.
10. Install split packing gland [1312] over threaded studs [1305] with gland clamps, flatwashers, lockwashers, and hex adjusting nuts [1304, 1303, 1302, 1301]. Refer to Figure 8A, page 25. The split packing gland must be square with the packing housing [1314]. Finger tighten the hex adjusting nuts [1301].
11. Let the packing set for five to ten minutes so that it can cold flow and adjust to the gland pressure. Loosen the hex adjusting nuts, then finger tighten. After starting the unit, the packing will require adjusting. Refer to SHAFT SEALS - OPERATION.
12. Continue with the agitator installation.

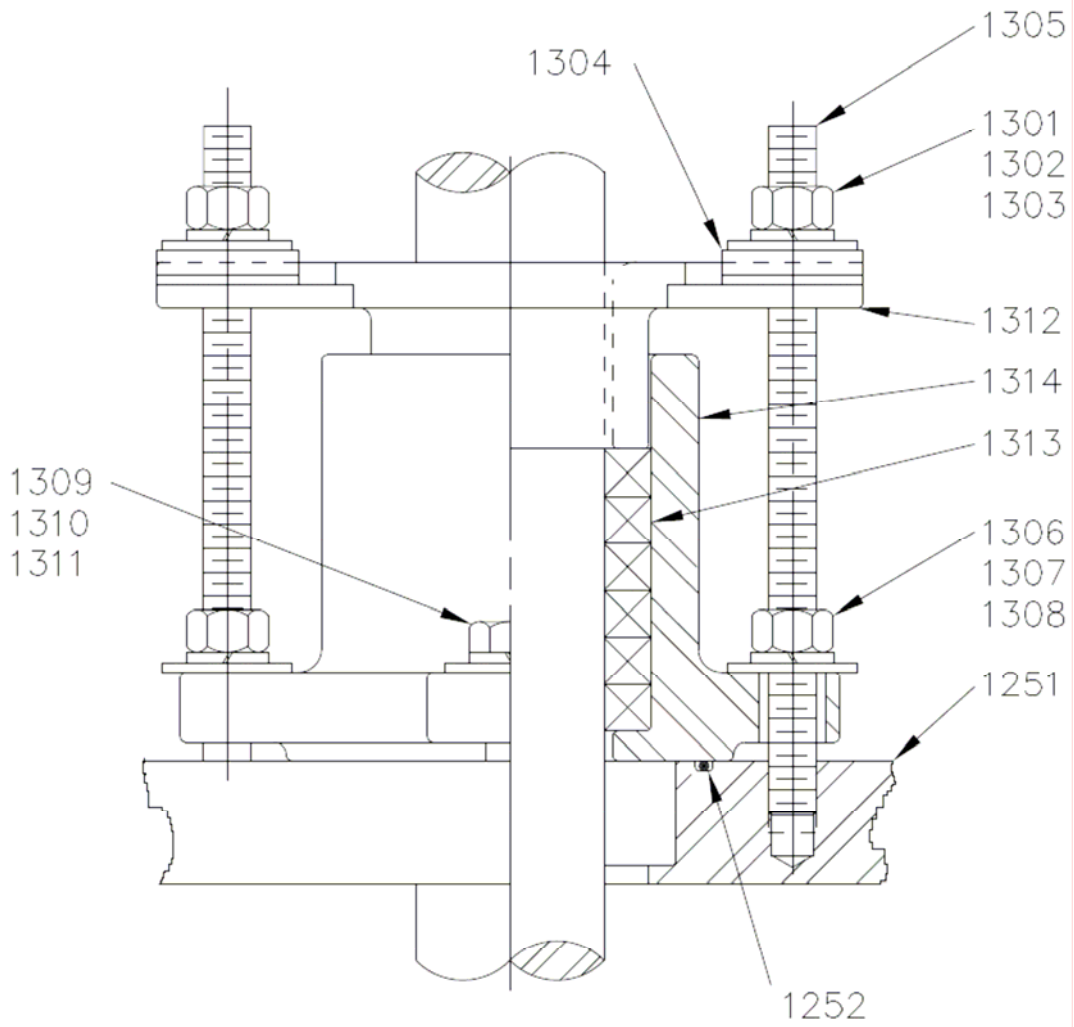

Figure 8A. Auxiliary Stuffing Box (cast housing)

H.3 BOLT-IN STUFFING BOX DESIGN (FABRICATED HOUSING)

1. Assemble the flange **[1251]** to the vessel with the proper gasket and bolts (supplied by others).
2. If a removable coupling is supplied with the unit, lift the agitator extension shaft and lower it into the vessel. Lift the shaft up through the mounting flange from inside the vessel and block it in place such that the shaft extends above the gearbox mounting surface. If a welded or shrink fit coupling is already assembled onto the shaft, the shaft will need to be lowered down into the flange and blocked in place in this manner.
3. Place o-ring **[1252]** into the groove in the mounting flange **[1251]**.
4. Install the packing housing **[1314]**, clamping gland **[1315]** and packing rings **[1313]**. Do not bolt down the clamping ring at this time. Stagger each packing split by 90° during installation. Seat each packing ring one at a time as it is installed.
5. Install the two threaded studs **[1305]** at 180° from each other.
6. Install gland plate, nuts and flatwasher **[1355, 1306, 1308]** onto studs. *Do not tighten at this time.*
7. Install four flatwashers and bolts **[1311, 1316]**. *Do not tighten at this time.*
8. Install the extension shaft removable coupling (if applicable). Follow instructions in Section J, page 30, in order to install the gearbox and taper bore coupling.
9. Tape gland plate **[1355]** to the extension shaft coupling half. Attach an indicator to the extension shaft and set the point of the indicator on the inside diameter of the stuffing box housing. Align the stuffing box housing to within .005" (0.127 mm) FIM of the shaft centerline and then tighten bolts **[1316]** and nuts **[1306]**. Torque to the value shown in APPENDIX, Page 100.
10. Install split gland **[1356]**. Refer to Figure 8B, page 27. The split packing gland must be square with the packing housing **[1314]**. Finger tighten the hex adjusting nuts **[1301]**.
11. Let the packing set for five to ten minutes so that it can cold flow and adjust to the gland pressure. Loosen the hex adjusting nuts, then finger tighten. After starting the unit, the packing will require adjusting. Refer to SHAFT SEALS - OPERATION.
12. Continue with the agitator installation.

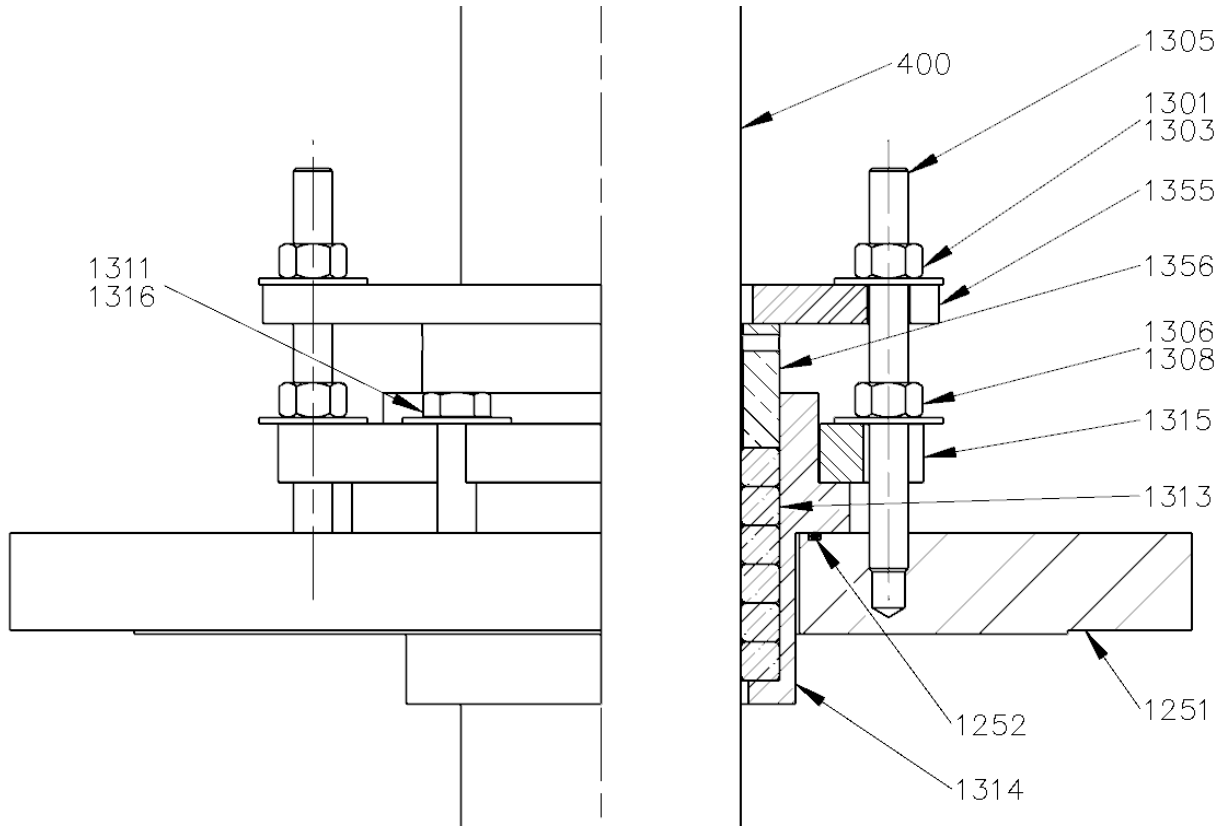

Figure 8B. Auxiliary Stuffing Box (fabricated housing)

I. SEAL INSTALLATION - AUXILIARY LIP SEAL

Applicable to: Model 20GTD (w/Auxiliary Seal) and Model 20 HTD (w/Auxiliary Seal)

1. Remove snap ring [1852] and lip seal [1853] from flange [1851].
2. Assemble the auxiliary lip seal flange to the vessel with the proper gasket and bolts (supplied by others). *Do not install the bolts at this time.*
3. Lower extension shaft [400] into the vessel through the auxiliary lip seal flange. If the extension shaft coupling half is not installed, the shaft may be lifted up through the auxiliary lip seal from inside the tank. Block the shaft from inside the vessel such that the extension shaft extends above the agitator drive mounting surface.

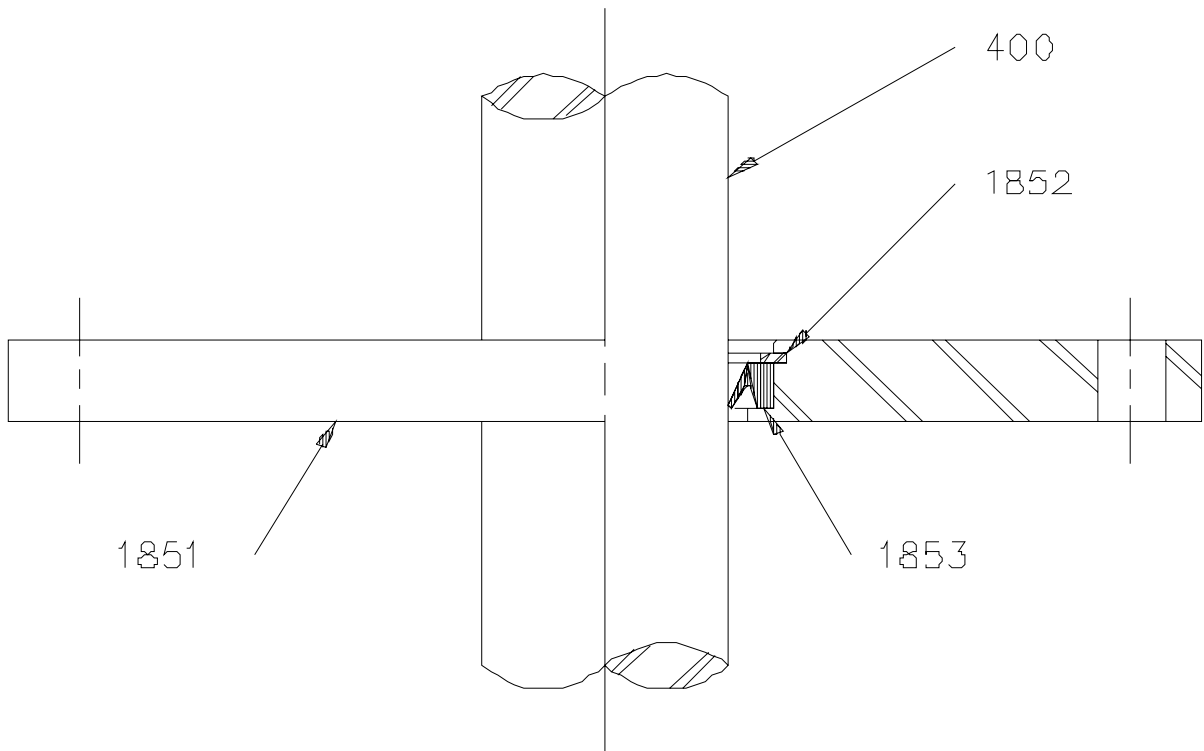

Figure 9. Auxiliary Lip Seal

4. Place the lip seal and the snap ring over the extension shaft. Assemble lip seal and snap ring to the flange.
5. Install the extension shaft coupling half if required. Follow instructions in Section J, page 30 in order to install the gearbox and taper bore coupling.
6. Lift the agitator drive (Figure 11, page 31).

7. Suspend the agitator drive assembly over the extension shaft coupling half, close enough to allow installation of coupling bolts and lockwashers **[359, 360]**. The coupling faces and tenons must be clean and free of nicks or burrs. Install two bolts and lockwashers at 180°. Tighten the bolts to engage the tenon and pull the coupling faces together.
8. Lift the agitator drive assembly and the extension shaft. Remove the shaft blocking. Install the remaining coupling bolts and lockwashers. Torque to the value shown in APPENDIX, Page 100.
9. Lower the agitator drive assembly onto the support structure. Install the mounting bolts (supplied by others). *Do not tighten the bolts at this time.*
10. Install the auxiliary lip seal flange bolts finger tight. If the bolt holes in the lip seal flange and the vessel flange are not properly aligned, the agitator drive will have to be moved laterally or shimmed. If shimming is required, use full width shims under the mounting feet to provide a solid joint for bolting the agitator drive to the support structure. Torque the agitator drive mounting bolts to the value shown in APPENDIX, Page 100. Then torque the auxiliary lip seal flange bolts to the value shown in APPENDIX, Page 100.
11. Auxiliary lip seals do not require any adjustment or lubrication. Both Buna-N and Teflon lip seals as supplied are not split.
12. Continue with the agitator installation.

J. TAPER BORE COUPLING AND GEAR DRIVE INSTALLATION

J.1 SHAFT TAPER COUPLING INSTALLATION

1. Clean the extension shaft [400] and coupling half [351] bore and make sure that both surfaces are free from burrs or nicks. Place key [352] in the coupling keyway to make sure it slides freely. Install the key in the shaft keyway making sure it is properly oriented and fully bottomed in the keyway.

NOTE: Do not apply lubricant or anti-seize compound to coupling taper. Shaft and coupling tapers must be clean, dry and free of nicks.

2. Slide the coupling half onto the tapered shaft end until both seat firmly against each other. Make sure that the coupling half is not hung up on the key or cocked at an angle to the shaft.

NOTE: Avoid surface damage and bending of the shaft. Protect the tenon and the face of the coupling. These surfaces must be perfectly clean and free of nicks.

3. Install shaft bolts:

2 Bolt Design: Install coupling washer [354]. Install bolts [357] and lockwashers [358]. Torque bolts to the value shown in the APPENDIX, Page 100.

1 Bolt Design: Install coupling washer [353]. Install bolt [355] and lockwasher [356]. Torque bolts to the value shown in the APPENDIX, Page 100.

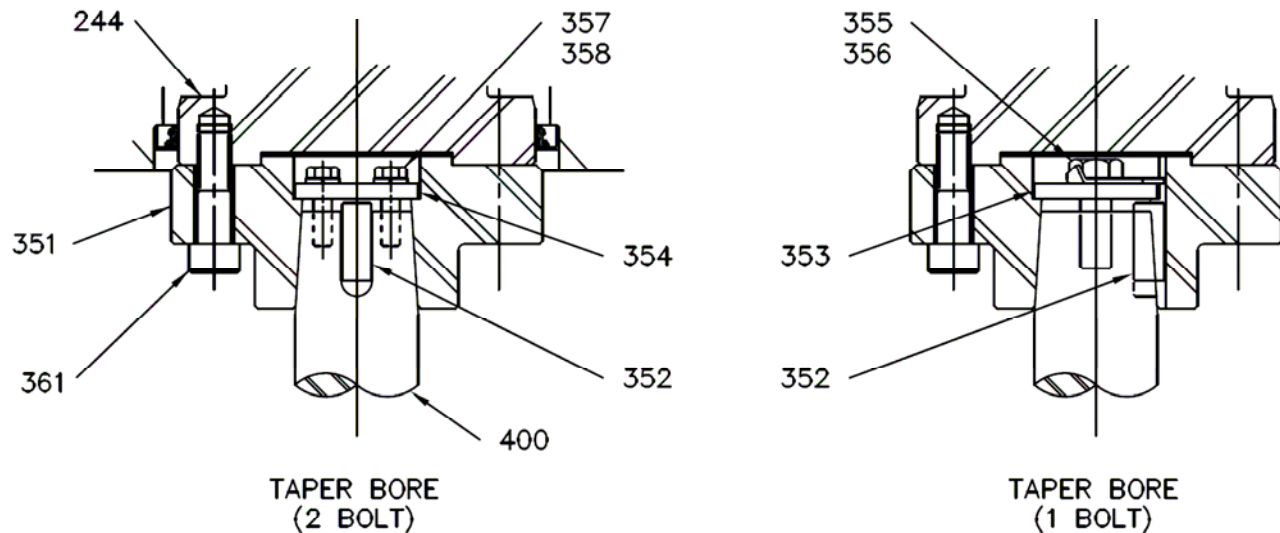

Figure 10. Shaft Coupling Installation

J.2 GEARBOX INSTALLATION

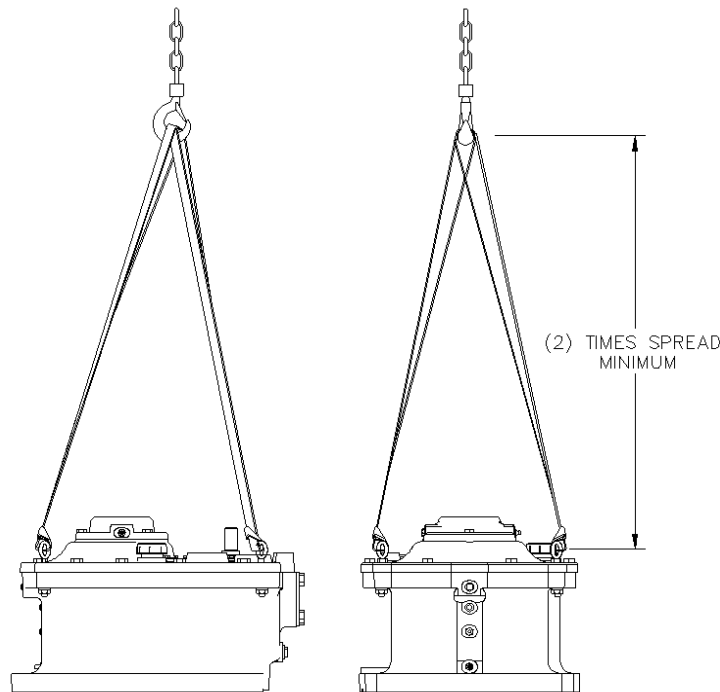

Figure 11. Agitator Lifting System

1. Lift and suspend the agitator drive assembly over the extension shaft coupling half close enough to allow installation of coupling bolts [361]. Install two bolts at 180 degrees. Tighten the bolts to engage the tenon and pull the coupling faces together.
2. Lift the agitator drive assembly and the extension shaft enough to remove shaft blocking. Remove blocking and install the remaining coupling bolts. Torque bolts to the value shown in the APPENDIX, Page 100.
3. ***For GTD/HTD units only:*** Lower the agitator drive assembly onto the support structure. The gear drive assembly must be level within $\frac{1}{4}$ degrees (.05 inches per foot; 4.4 mm per meter). If shimming is required, use full width shims under the agitator drive housing to provide a solid joint for bolting the agitator drive assembly to the support structure. Install the agitator drive mounting bolts (supplied by others) and torque to the value shown in the APPENDIX, Page 100. *Ignore further steps in this section. Go to the [Shaft Runout Section](#), page 32.*
4. ***For GTP/HTP units only:*** Install the pedestal hand hole cover bolts and lockwashers [1106, 1107], and location shoulder bolt and dowel pin [1115, 1118] into the pedestal [1101]. Lower the agitator drive assembly onto the pedestal and mount with bolts, lockwashers and nuts [1102, 1103, 1104]. Torque bolts to the value shown in the Appendix, Page 100. Refer to the agitator assembly drawings. Continue to install the hand hole covers per Section L, page 33.

K. SHAFT RUNOUT

NOTE: The runout values provided in this section do not apply to the runout measurements for shafts with steady bearings. Refer to the steady bearing section for the requirements for steady bearing unit shafts.

1. Check the installed extension shaft runout. Place a dial indicator on the side of the extension shaft at the bottom. Manually turn the flexible motor coupling to rotate the extension shaft one turn.
2. Total shaft runout should not exceed .005" per foot (0.42 mm per meter) FIM (Full Indicator Movement) of shaft length. If the shaft runout is excessive, the shaft can be re-straightened in the field. Rotate the shaft to the maximum positive indicator reading. Apply heat to the shaft at a point 180° from the indicator and just below the first in-tank shaft coupling or just below the mounting surface if there is no in-tank coupling. As heat is applied to the shaft (do not allow surface temperature of shaft to exceed 500°F [260°C]), the shaft will move toward the indicator. After the shaft has moved .030-.060" (0.76-1.52 mm), remove the heat and the shaft will begin to move away from the indicator. The shaft will draw more than it moved initially, and as a result will be straightened. After each heating cycle, recheck the shaft until runout is within tolerance. Do not heat in the same location. Move up or down 2 or 3" (50-70 mm) to avoid reheating the same location

L. HANDHOLE COVER INSTALLATION

For case sizes 21 and 22: Install handhole covers [1105] onto pedestal. Attach flatwasher, lockwasher and nut [1108, 1109, 1110] to previously installed bolt and lockwasher [1106, 1107] and tighten.

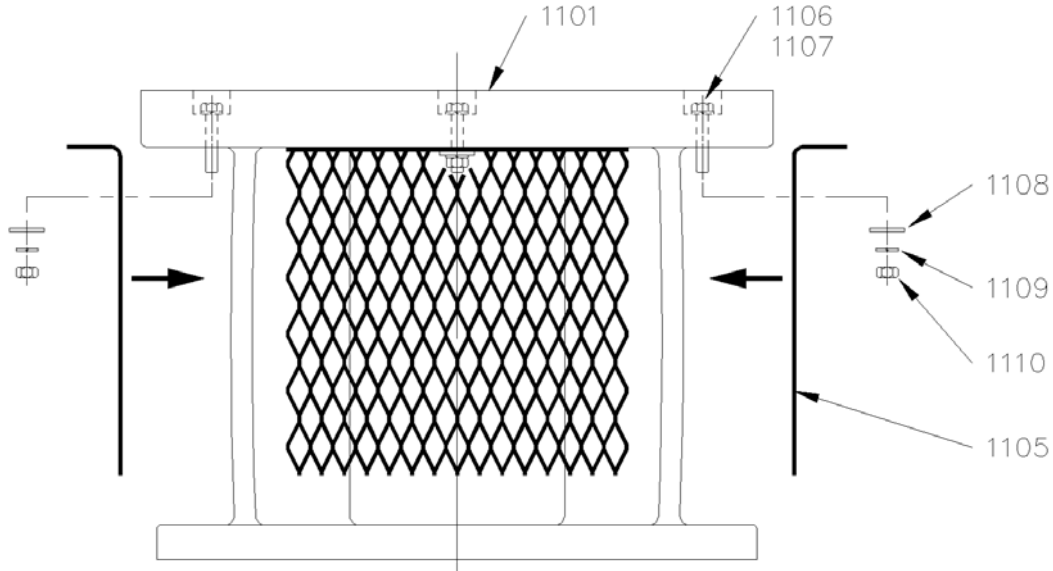

Figure 12. Handhole Cover Installation (case sizes 21 and 22)

For case sizes 23: Install three of the four handhole covers [1135] using flatwasher, lockwasher and nut [1138, 1139, 1130] to previously installed bolt and lockwasher [1136, 1137] and tighten. Install the fourth cover using bolt [1141], lockwasher [1142] and flatwasher [1143].

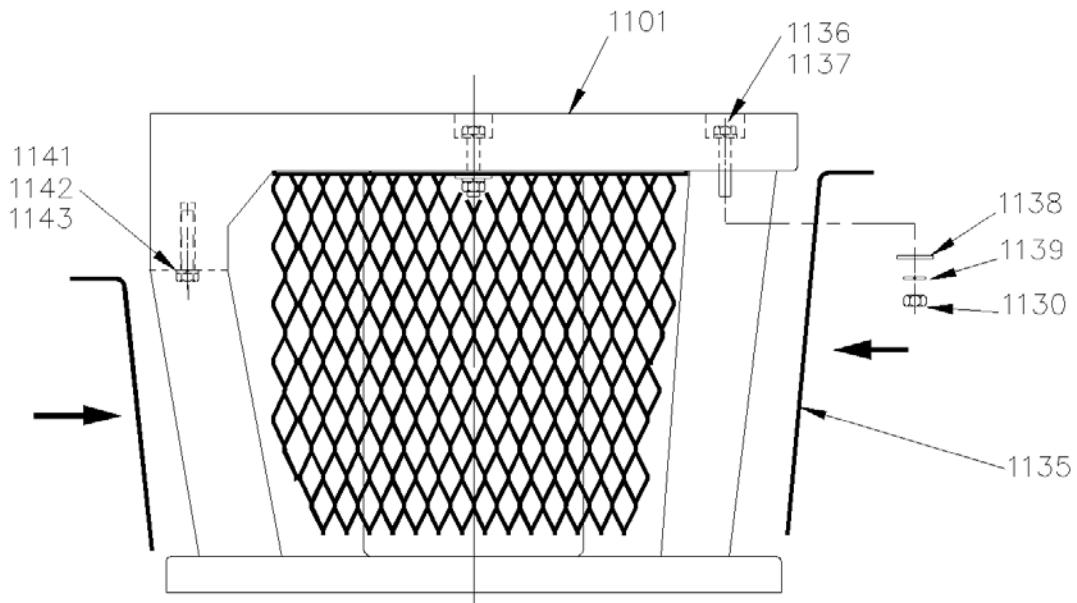

Figure 13. Handhole Cover Installation (case size 23)

M. MOTOR INSTALLATION

1. Orient motor onto adapter with conduit box in an accessible position. Install motor mounting bolts [135] and lockwashers [136]. Torque bolts to the value shown in the APPENDIX, Page 100.

Do not install the motor/motor adapter assembly [100, 131], until after the gear drive [200] has been installed on the pedestal [1101] and the mechanical seal cartridge is completely installed. The procedure for the installation of the mechanical seal and any optional steady bearing assembly will require access to the gear drive input shaft.

2. The default flexible motor coupling [110] used on all Chemineer Model 20 agitators is the Sure-Flex[®] coupling unless otherwise specified. Refer to coupling vendor's instruction supplied with coupling for installation instructions.
3. Measure and mark the setting distance on the motor shaft as per Table 5, page 34. Install the flexible coupling hub with motor key [101] on the motor shaft as per the marking (See Table 5 or Table 6 and Figure 14). Tighten the hub setscrews to the torque value shown in the APPENDIX, Page 100. Turn the motor shaft by hand to check that the shaft rotates freely.

Table 5. MOTOR (NEMA) COUPLING SETTING

CASE SIZE	MOTOR FRAME SIZE (NEMA)								
	56C	143TC 145TC	182TC 184TC	213TC 215TC	254TC 256TC	284TC 286TC	324TC 326TC	364TC 365TC	404TC 405TC
21	1.06 in (27 mm)	1.13 in (29 mm)	1.25 in. (32 mm)	1.63 in (41 mm)	N/A	N/A	N/A	N/A	N/A
22	N/A	N/A	1.13 in (29 mm)	1.63 in (41 mm)	1.94 in (49 mm)	2.25 in (59 mm)	2.44 in (62 mm)	N/A	N/A
23	N/A	N/A	1.06 in. (27 mm)	1.31 in. (33 mm)	1.69 in (43 mm)	1.88 in. (47 mm) 2.31 in. ^{**} (59 mm) ^{**}	2.50 in. (63 mm)	2.19 in (55 mm), 3.13 in. ⁺⁺ (79 mm) ⁺⁺	3.31 in. (85 mm)

*** Use this for 280 Frame, 30 Hp motor at 1755 rpm input*

++ Use this for 360 Frame, 75 Hp motor at 1755 rpm input

++ Use this for 360 Frame, 50 Hp motor at 1170 rpm input

Table 6. MOTOR (IEC) COUPLING SETTING

CASE SIZE	MOTOR FRAME SIZE (IEC)							
	IEC 80	IEC 90	IEC 100 IEC 112	IEC 132	IEC 160 IEC 180	IEC 225	IEC 250	IEC 280
21 GT/HT	22 mm (0.87 in.)	25 mm (1.0 in.)	32 mm (1.26 in.)	40 mm (1.57 in.)	N/A	N/A	N/A	N/A
22 GT/HT	N/A	N/A	26 mm (1.0 in.)	34 mm (1.34 in.)	51 mm (2.00 in.)	N/A	N/A	N/A
23 GT/HT	N/A	N/A	N/A	36 mm (1.42 in.)	52 mm (2.0 in.)	76 mm (3.0 in.)	60 mm (2.36 in.)	82 mm (3.23 in.)

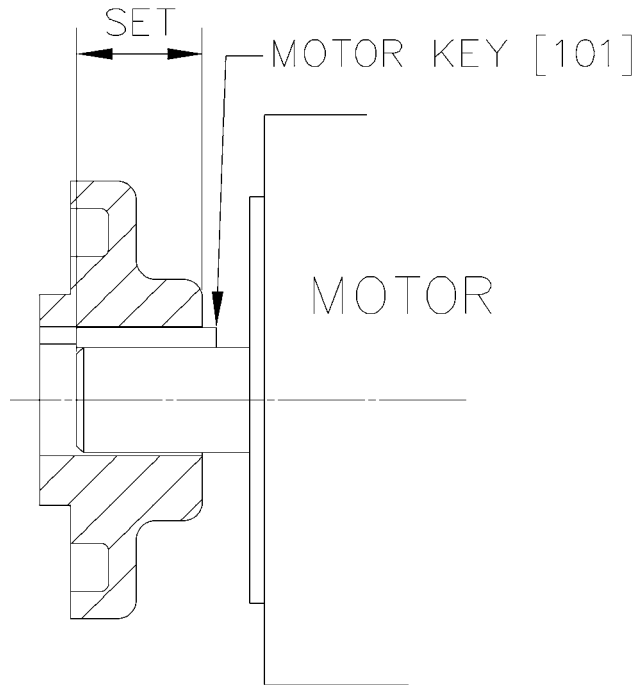

Figure 14. Motor Coupling Setting

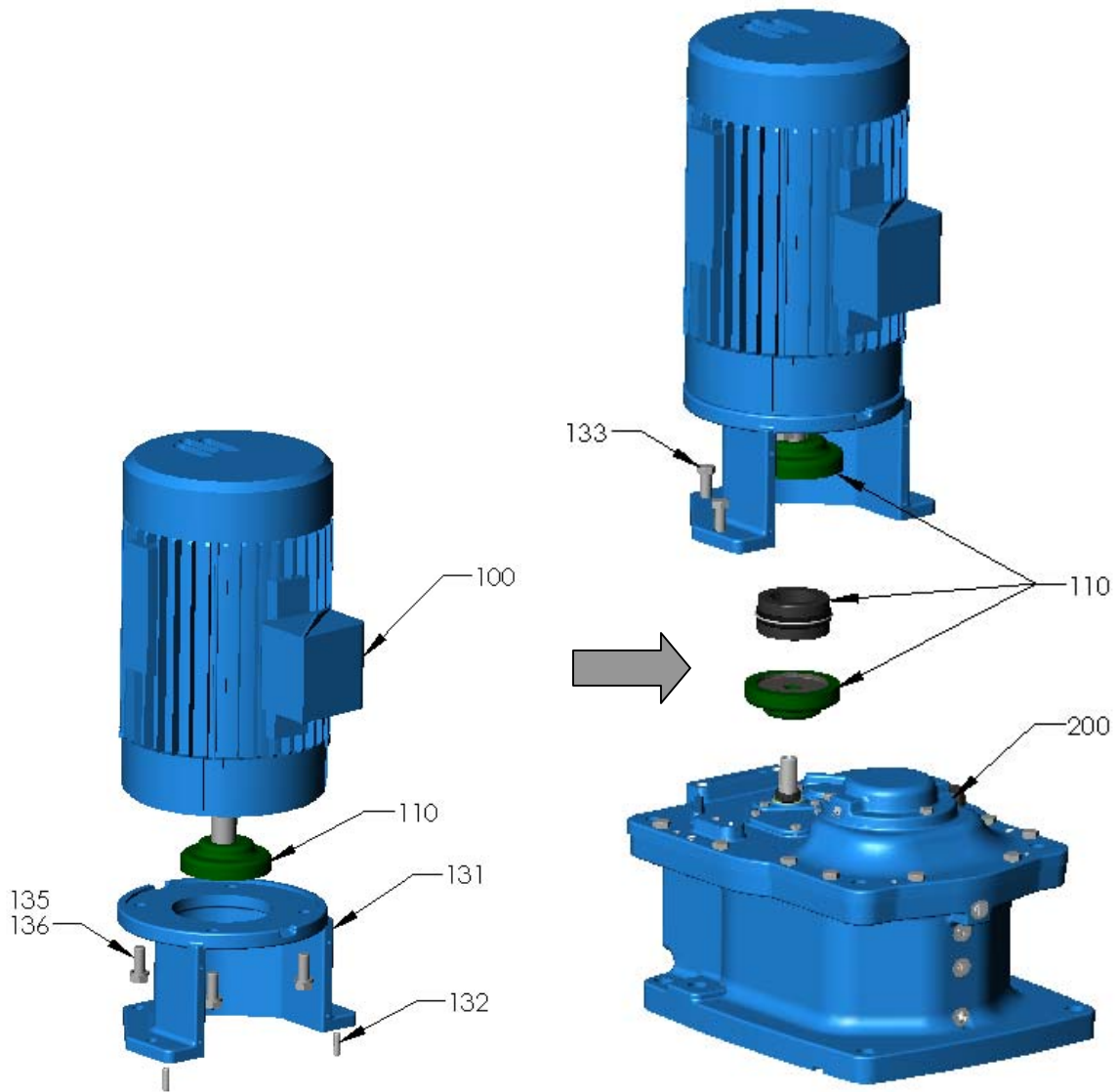

Figure 15. Model 20 GT – Motor Mounting

Note: Gear drive is already installed on the pedestal or beams (not shown) before mounting the motor

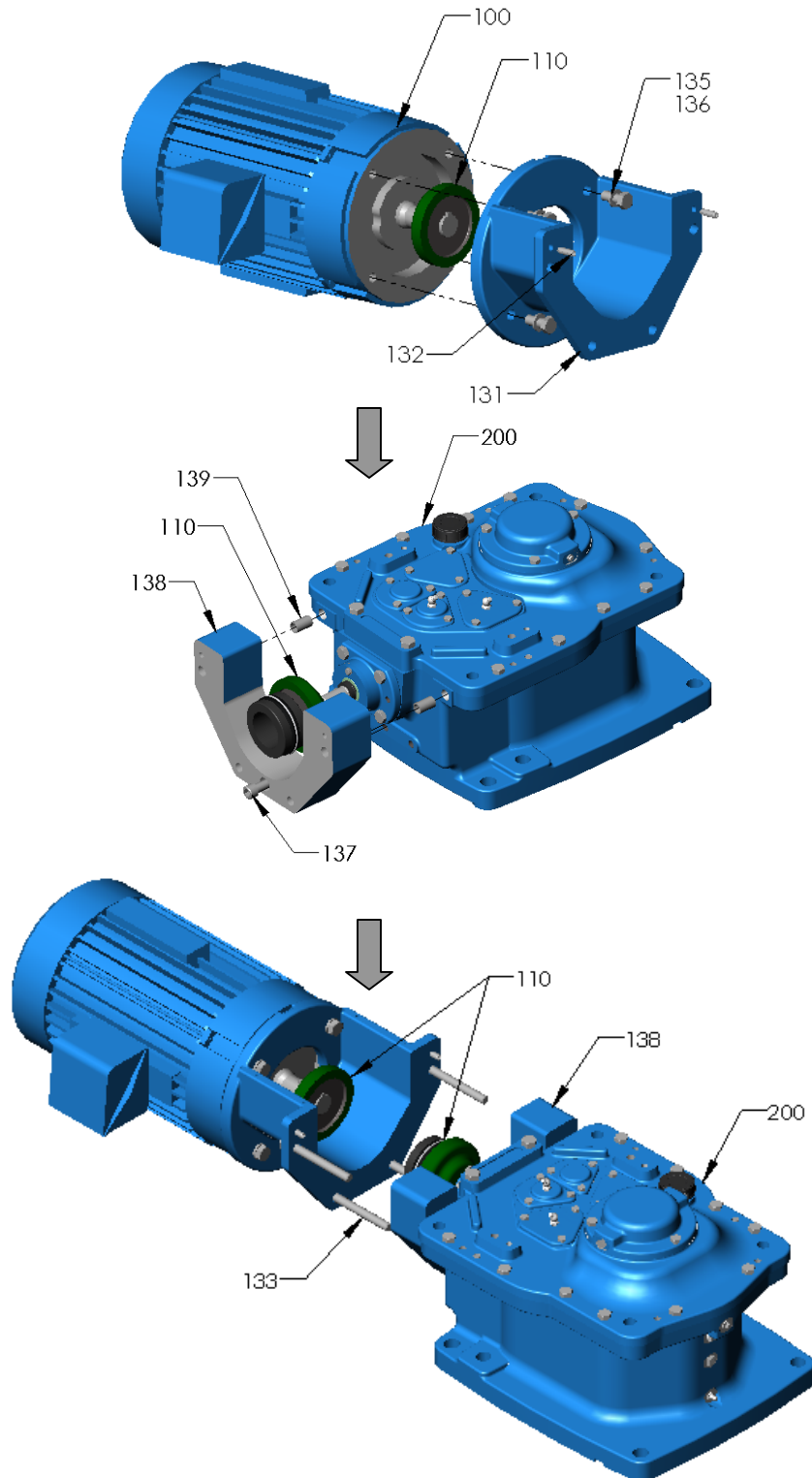

Figure 16. Model 20 HT – Motor Mounting

Note: Gear drive is already installed on the pedestal or beams (not shown) before mounting the motor

4. Assemble the motor adapter [131] to the motor [100] using motor fastener kit [135, 136]. Install the remaining flexible coupling hub with input shaft key [269] onto the gear drive input shaft. Set the coupling sleeve on this hub. Install alignment pins [132] on to the motor adapter.
5. **For GT (Parallel Drive):** Using a hoist system, lift motor/adapter assembly above gear drive and lower onto the holes on the gear drive for alignment pins. Install bolts [133] to assemble the motor adapter onto the gear drive. Torque the bolts [133] to the value shown in the APPENDIX, Page 100. Raise the lower flexible coupling hub and tighten the setscrews to the torque value shown in the APPENDIX, Page 100.
For HT (Right Angle Drive): Using the shoulder bolt [137], install the spacer [138] with the bushings [139] (see Figure 16, page 37). Using a hoist system, lift motor/adapter assembly in a horizontal position parallel to the gear drive, as shown in Figure 16, page 37. Install the motor/adapter assembly on to the spacer using bolts [133]. Torque the bolts [133] to the value shown in the APPENDIX, Page 100. Slide the flexible coupling hub attached to the gear drive and tighten the setscrews to the torque value shown in the APPENDIX, Page 100.
6. The flexible coupling will not require alignment maintenance after installation. Install motor adapter cover plate, and bolts [121, 122].

N. IMPELLERS

***NOTE:** The instructions in this section apply to standard impeller geometry. Due to the custom nature of impeller designs for certain applications, your impeller geometry may vary from the standard configurations shown in this manual. Use discretion and consult the supplied customer specific drawings for installation specifics if your impellers do not match those shown in this manual.*

N.1 MATCH-MARKING

Unless otherwise specified on the unit assembly drawing, the impeller attaches to the shaft with a key and setscrew. Refer to Figure 17, page 40. With extended shaft keyways, the keyway is drilled at intervals for optional impeller placement.

Impeller assemblies (hub, blades, and stabilizer fins [if required]) may be match-marked. Match-marking is used on impellers that have been balanced or as an aid for locating multiple impellers on the shaft. Most agitators operating at or above 100 RPM have match-marked impellers. Check the impeller parts for match-marks before assembly.

Match-marked components are marked as a function of the agitator serial number and impeller location. Impellers are marked sequentially beginning with the bottom impeller and working up toward the agitator mounting surface. The following example assumes an order with two agitators, each having two 4-blade impellers with the lower impeller stabilized.

N.1.1 Markings for Serial Number XXXXXX-1

The lower impeller hub has stub blades marked 1-1, 1-2, 1-3, 1-4. The corresponding extension blades and stabilizer fins are marked 1-1, 1-2, 1-3, 1-4 with respect to the stub blades.

The upper impeller hub has stub blades marked 1-5, 1-6, 1-7, 1-8. The corresponding extension blades are marked 1-5, 1-6, 1-7, 1-8 with respect to the stub blades.

N.1.2 Markings for Serial Number XXXXXX-2

The lower impeller hub has stub blades marked 2-1, 2-2, 2-3, 2-4. The corresponding extension blades and stabilizer fins are marked 2-1, 2-2, 2-3, 2-4 with respect to the stub blades.

The upper impeller hub has stub blades marked 2-5, 2-6, 2-7, 2-8. The corresponding extension blades are marked 2-5, 2-6, 2-7, 2-8 with respect to the stub blades.

N.2 IMPELLERS - INSTALLATION

1. Slide hub [504] up agitator shaft [400] past the desired key location.
2. Install pin key [402] in the shaft keyway so that pin extends into the drilled hole in the keyway. Slide the hub back down agitator extension shaft, over the key, until the hub rests on the key step.
3. Tighten setscrew [505] firmly onto the key. Torque to the value shown in Table 17, page 100. The tapped hole for the setscrew is usually a self-locking thread form. Auxiliary fastener locking is generally not necessary.
4. Bolt extension blades [506] to the hub [504] with bolts, nuts and lockwashers [507, 509, 508]. Refer to Figure 18 through Figure 23, page 41 through 47. Bolt split blades, if furnished, to extension blades with bolts, nuts and lockwashers [529, 531, 530]. Bolt stabilizer fins [510], if furnished, to extension blades with bolts, nuts, and lockwashers [511, 513, 512]. Torque bolts to the value shown in Table 17, page 100.

NOTE: Extreme care should be taken to see that bolts are properly tightened. It is recommended that all in-tank fasteners be checked for tightness after the first two weeks of operation.

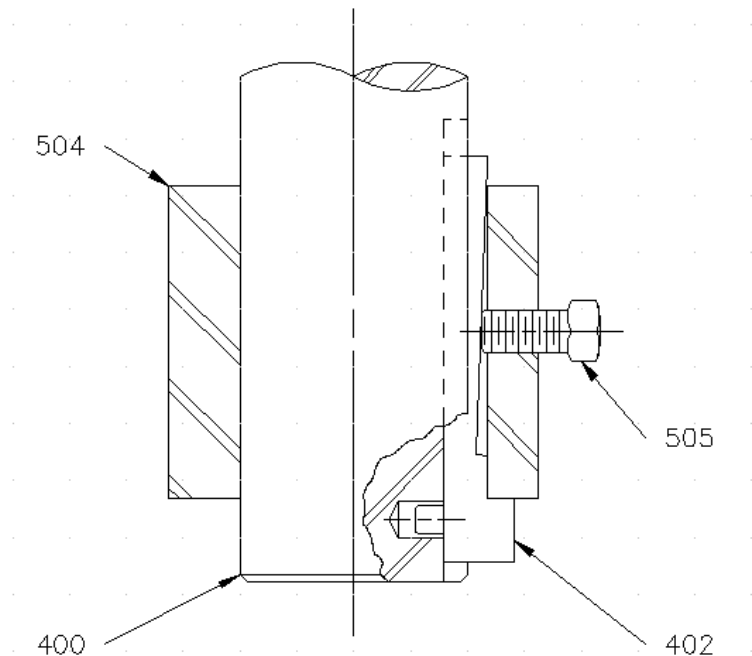

Figure 17. Hub and Pin Key Detail

N.3 IMPELLERS – STYLES

NOTE:
STABILIZER FINS FURNISHED
ONLY WHEN NECESSARY

NUMBER OF BLADE FASTENERS
MAY VARY WITH APPLICATION

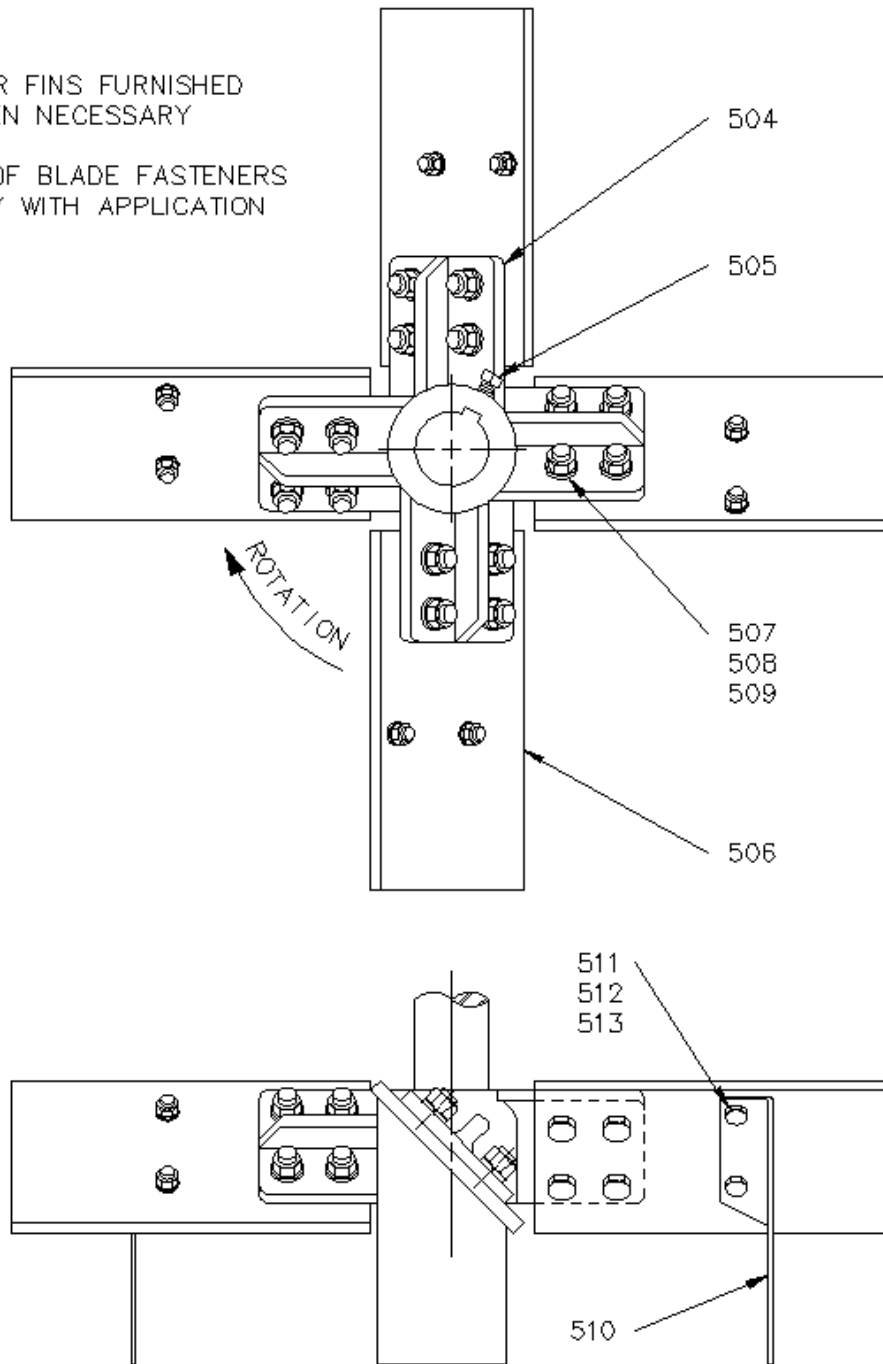
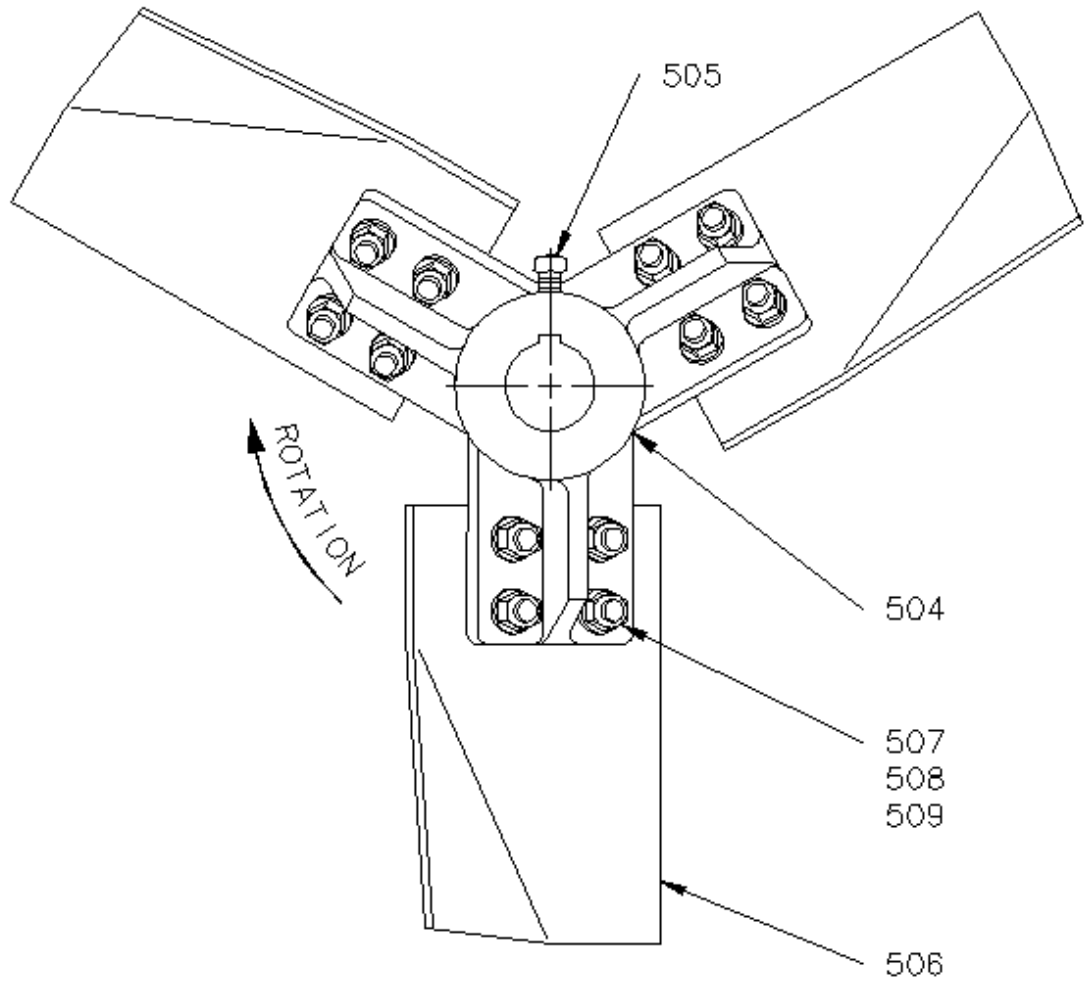

Figure 18. Style P-4 Impeller



NOTE:
NUMBER OF BLADE FASTENERS
MAY VARY WITH APPLICATION

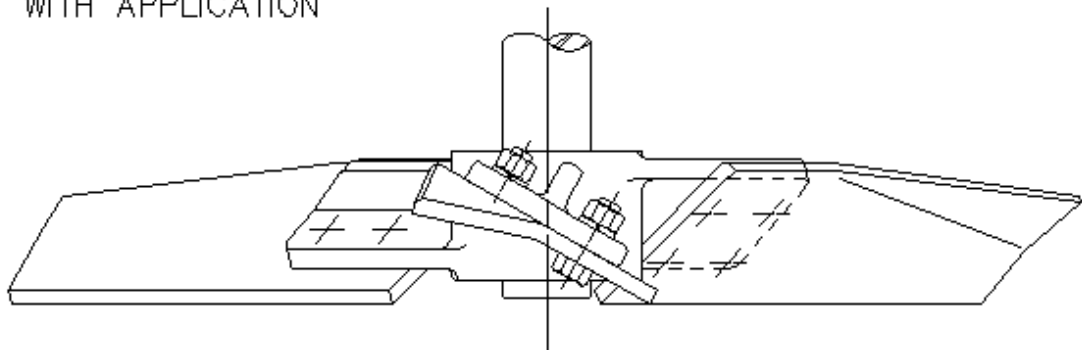
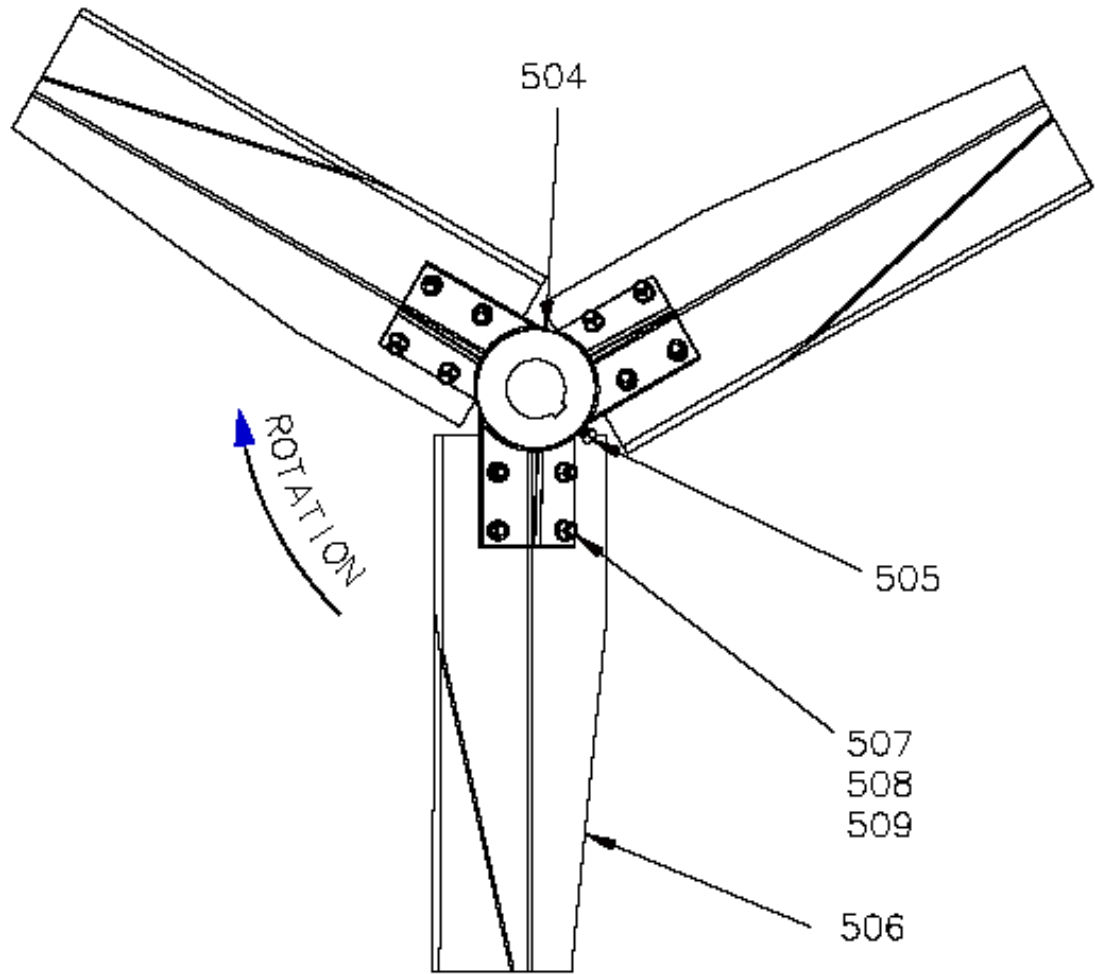

Figure 19. Style HE-3 Impeller



NOTE:
NUMBER OF BLADE FASTENERS
MAY VARY WITH APPLICATION

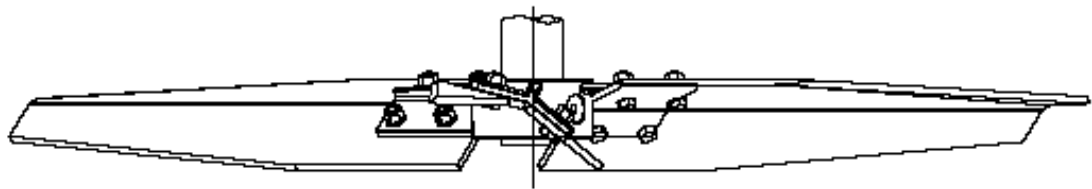

Figure 19A. Style XE-3 Impeller

NOTE:
 STABILIZER FINS FURNISHED
 ONLY WHEN NECESSARY

NUMBER OF BLADE FASTENERS
 MAY VARY WITH APPLICATION

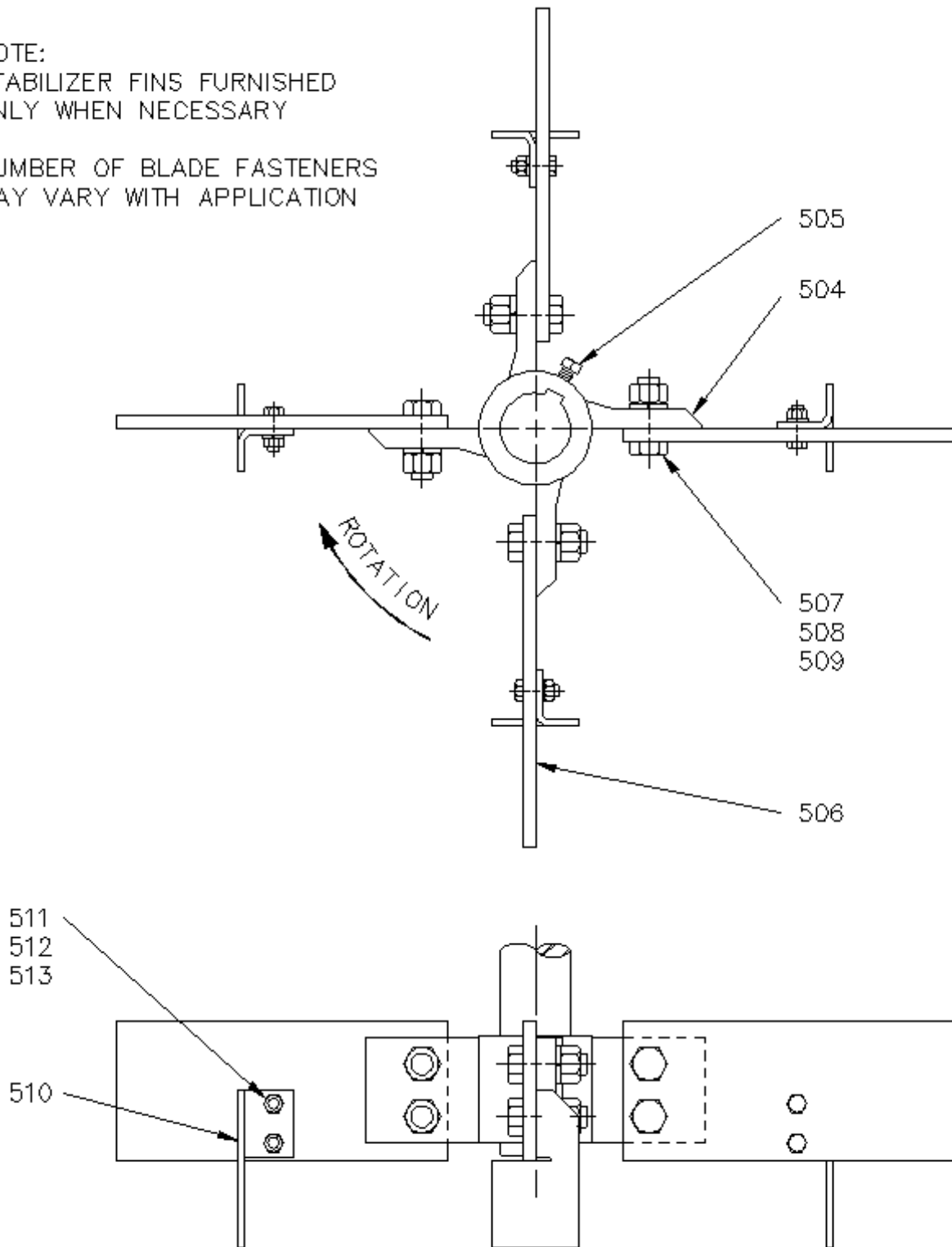

Figure 20. Style S-4 Impeller

NOTE:
NUMBER OF BLADE FASTENERS
MAY VARY WITH APPLICATION

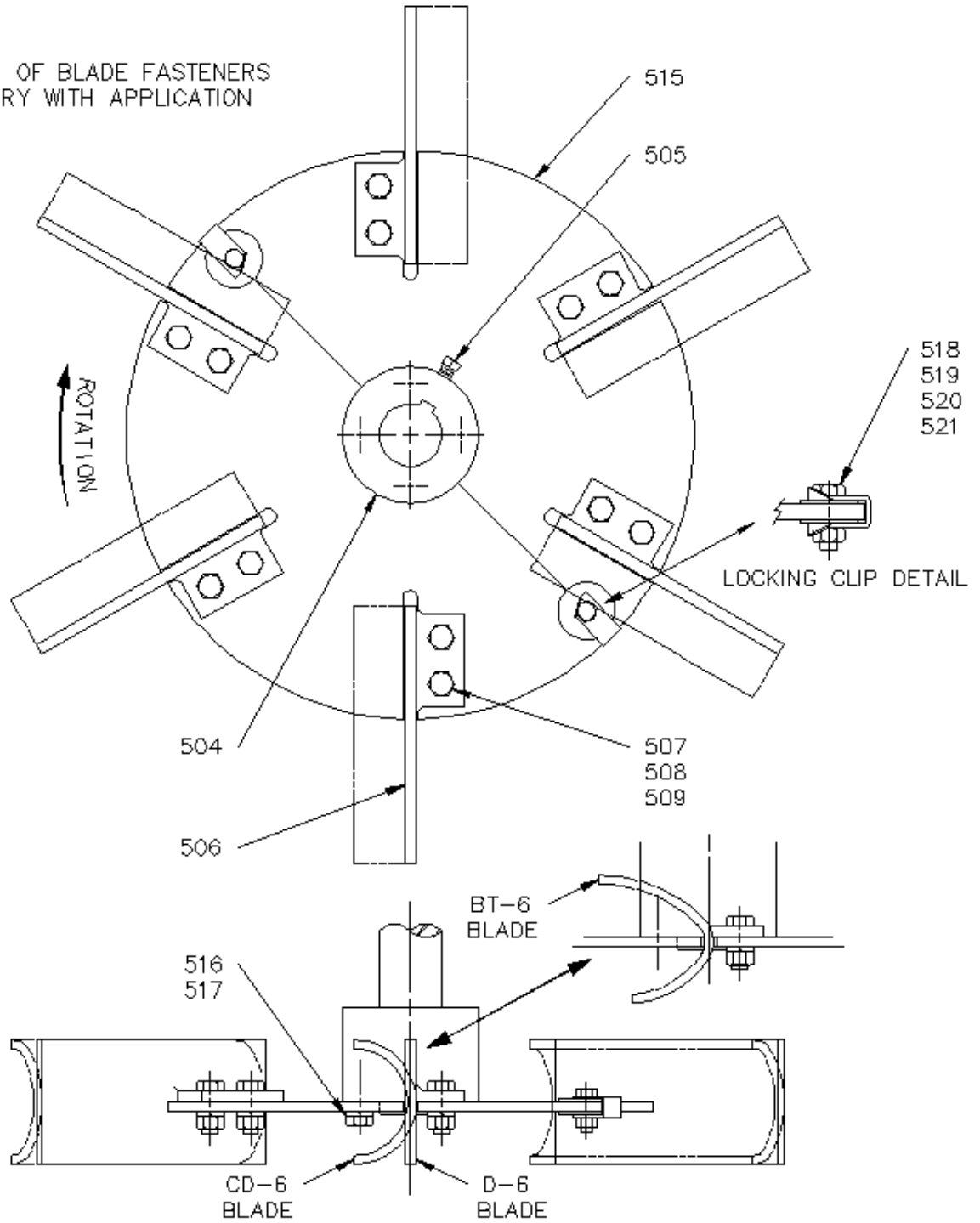
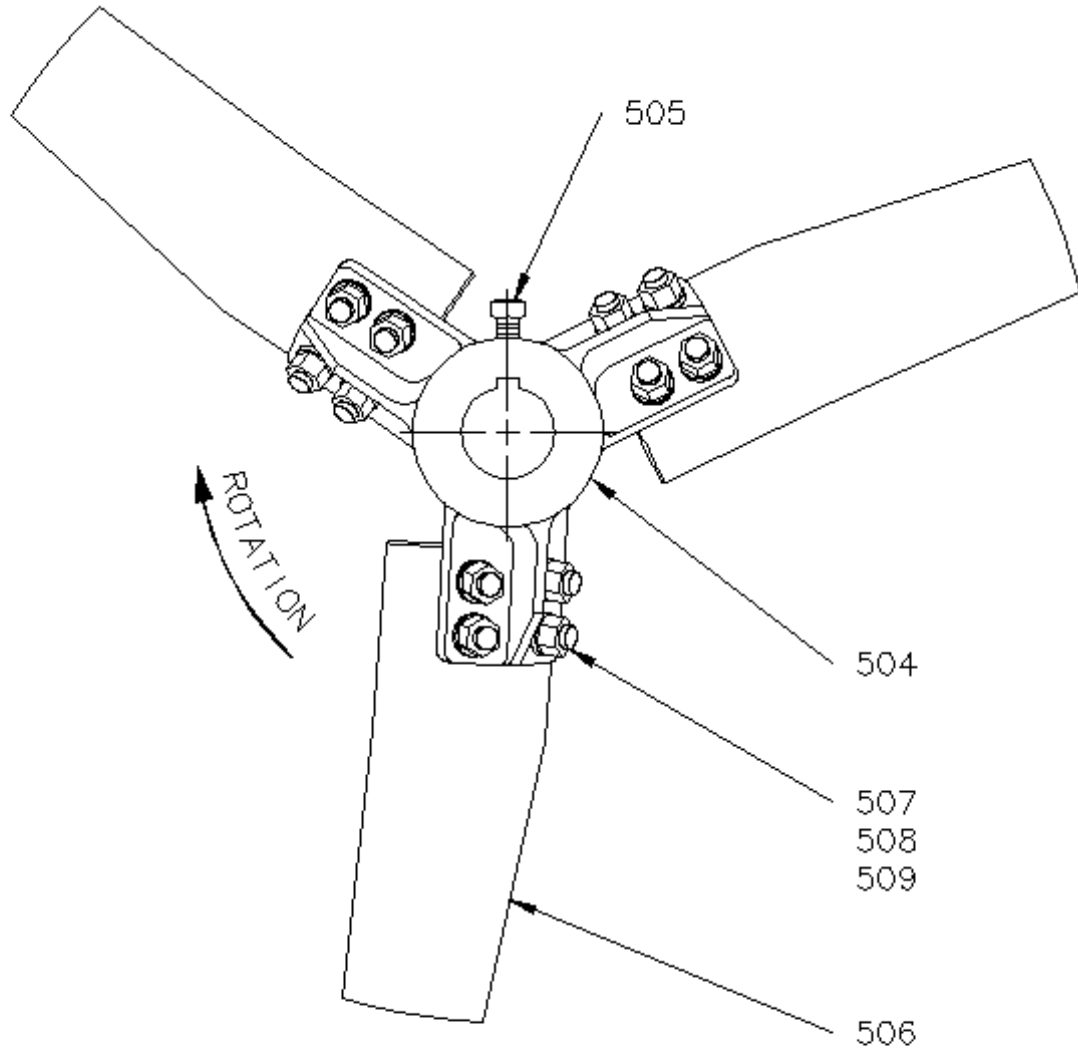

Figure 21. Style D-6, CD-6, BT-6 Impeller



NOTE:
NUMBER OF BLADE FASTENERS
MAY VARY WITH APPLICATION

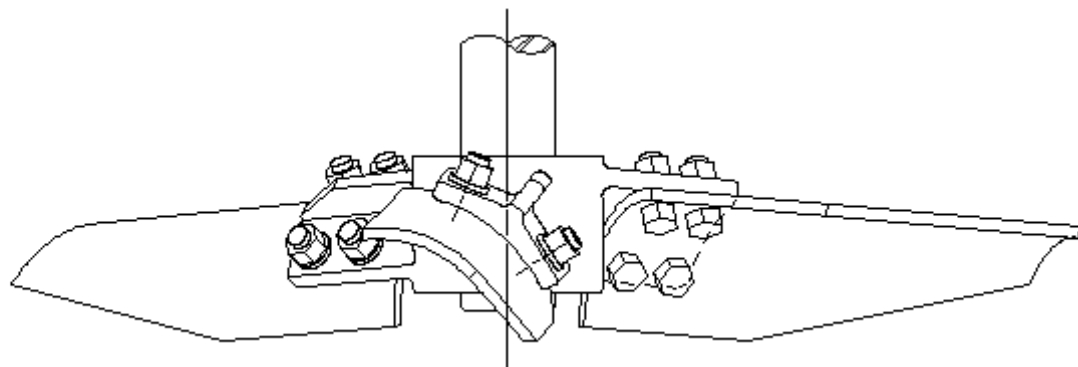

Figure 22. Style SC-3 Impeller

NOTE:
SPLIT BLADES FURNISHED
ONLY WHEN NECESSARY FOR
VESSEL INSERTION

NUMBER OF BLADE FASTENERS
MAY VARY WITH APPLICATION

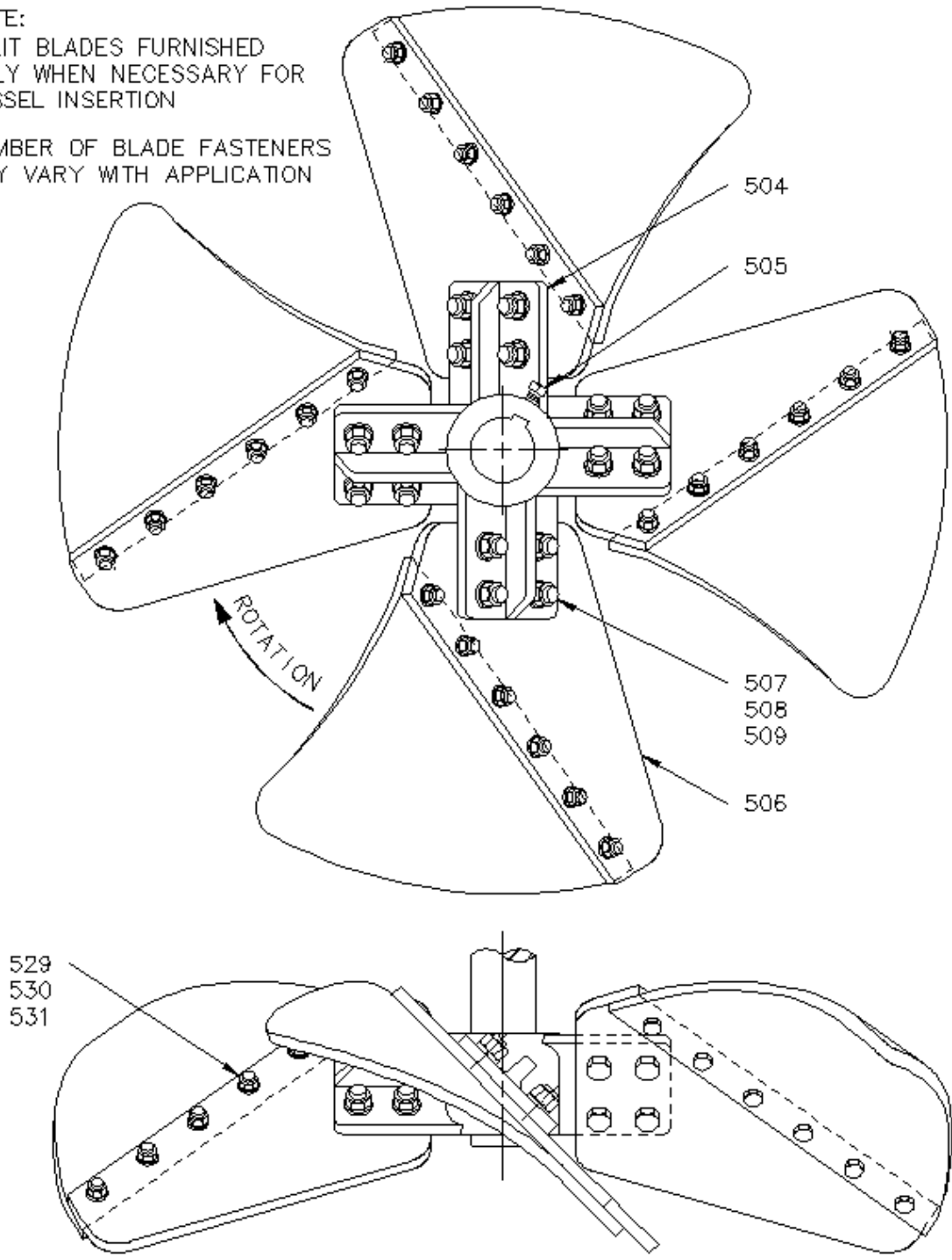

Figure 23. Style Maxflo W Impeller

N.4 IMPELLERS – COATED / RUBBER COVERED

If the unit includes a coating or rubber covering on the wetted parts, follow these instructions for installation. Refer to the unit assembly drawing.

N.4.1 One piece shaft and impeller

The shaft and impeller are usually supplied as a one-piece (welded) coated/covered assembly, and no impeller assembly is required. If your impeller was shipped separate from the shaft, follow the assembly instructions below.

N.4.2 Separate shaft and one piece impeller with thrust bolt impeller attachment

The impeller is supplied as a one-piece (welded) coated/covered assembly. For attachment to the shaft, refer to Figure 24, page 49.

1. Put gasket [522] on top of hub [504].
2. Install key [420] in the shaft keyway.
3. Hoist impeller onto shaft [400], being careful not to damage the coating/covering.
4. Install snap ring [523] in the groove at the bottom of the shaft.



CAUTION! Do not remove the hoist until mounting bolt assembly [522], [524], [525], and [526] are installed.

5. Place gasket [522] on thrust plate [524].
6. Place the thrust plate over the bottom of the shaft and install mounting bolt [526] with gasket [525]. Torque to the value shown in Table 17, page 100.
7. Remove the hoist from the impeller.

N.4.3 Removable blade type

The rubber covered removable blades are provided with patch kits in order to rubber coat the uncoated surfaces after bolting the blades.

Carefully read the instructions provided with the kit before using it.

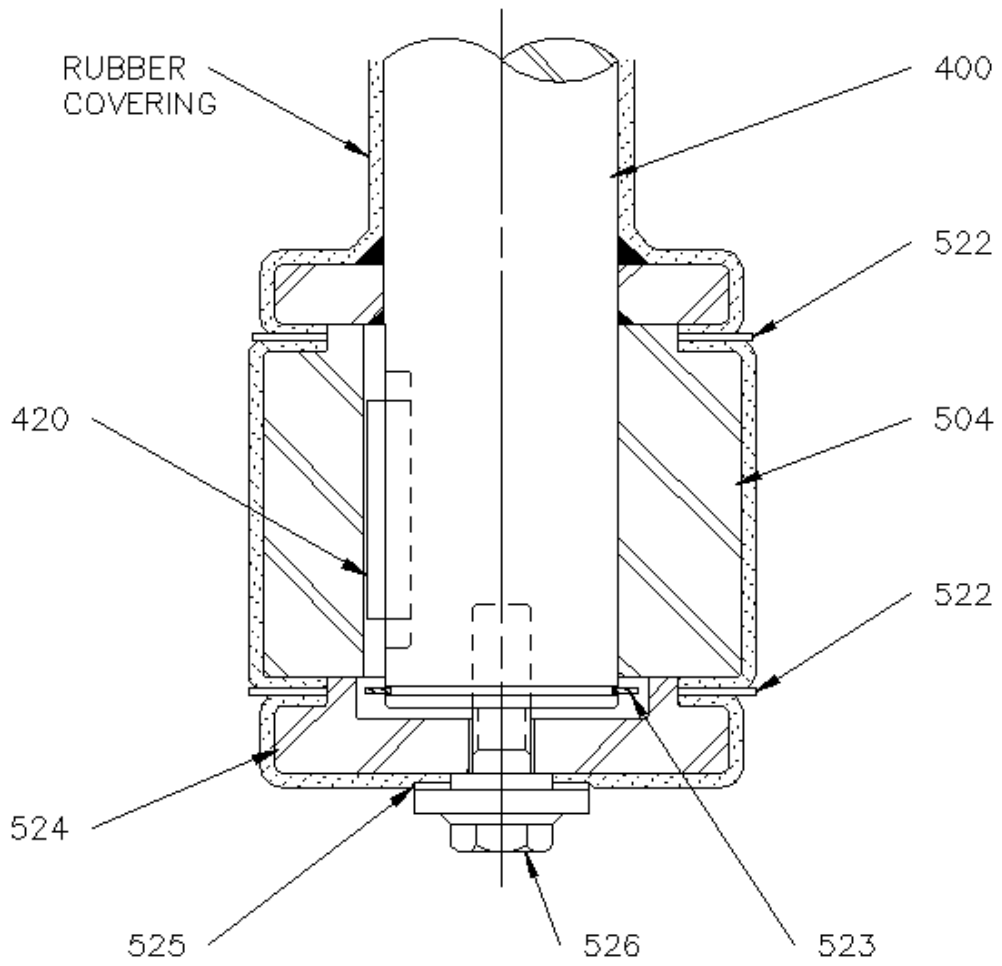

Figure 24. Thrust Bolt Impeller Attachment

O. OPTIONS

O.1 IN-TANK COUPLING

Optional in-tank couplings are available in welded (non-removable) and taper bore (removable) construction. Couplings can be supplied with one removable half and other welded on to the shaft.

NOTE: Whenever assembly or disassembly of an agitator with an in-tank coupling is referred to in this manual, substitute flanged drive shaft [403] and/or flanged extension shaft [404] (Figure 25 on page 51 or Figure 25A on page 52) for all references to the agitator extension shaft [400].

O.1.1 Assembly of Rigid, Removable, Taper Bore Coupling Half [408, 413]

1. Clean the shaft and coupling bore and make sure that both surfaces are free from burrs or nicks. Place key [409, 414] in the coupling keyway to make sure it slides freely. Place the key in the shaft keyway to make sure it is properly oriented and fully bottomed in the keyway. Install the key in the shaft keyway.
2. Slide the coupling half on the tapered shaft end until both seat firmly against each other. Make sure that the coupling half is not hung up on the key or cocked at an angle to the shaft.

NOTE: Do not apply lubricant or anti-seize compound to shaft or coupling taper. Shaft and coupling taper must be clean and dry prior to assembly.

3. Shaft Bolt Installation:

2 Bolt Design:

Install coupling washer [421, 424], Install bolts and lockwashers [422, 423, 425, 426]. Torque to the value shown in the APPENDIX, Page 100.

1 Bolt Design:

Install coupling washer [410, 415] and locking clip [412, 416], Install shaft bolt [418, 419]. Torque to the value shown in the APPENDIX, Page 100. Bend exposed tabs of the locking clip around the shaft bolt head.

4. Assemble Coupling Halves:

Connect flanged extension on shaft [404] to flanged drive shaft [403] making sure the match marks are lined up and the coupling faces are clean and free from burrs or nicks. Install coupling bolts and lockwashers [405, 406] (and nuts [407] if welded construction). Torque to the value shown in the APPENDIX, Page 100.

5. Ensure parts are fitted to the correct shaft.

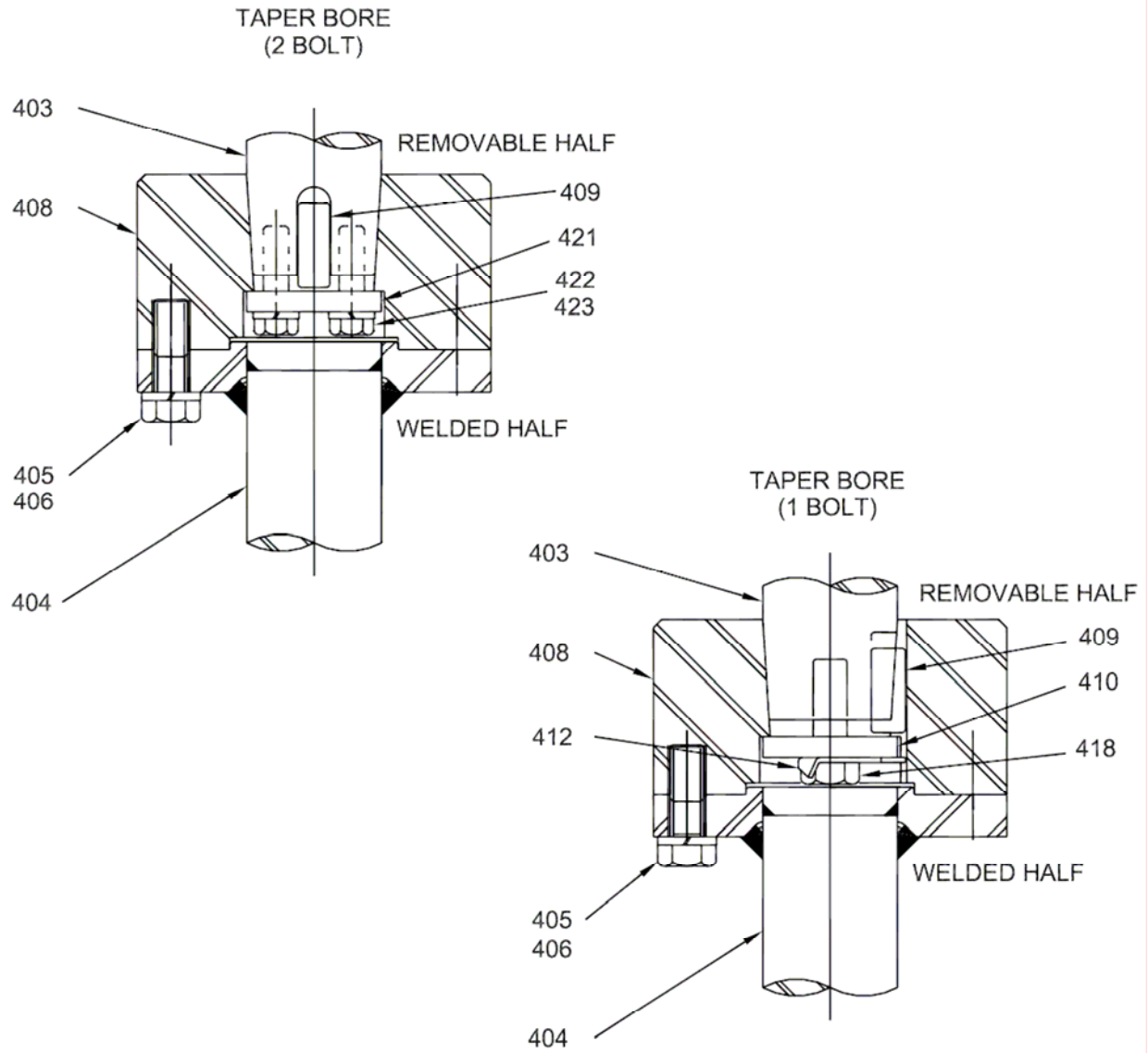

Figure 25. In-Tank Couplings

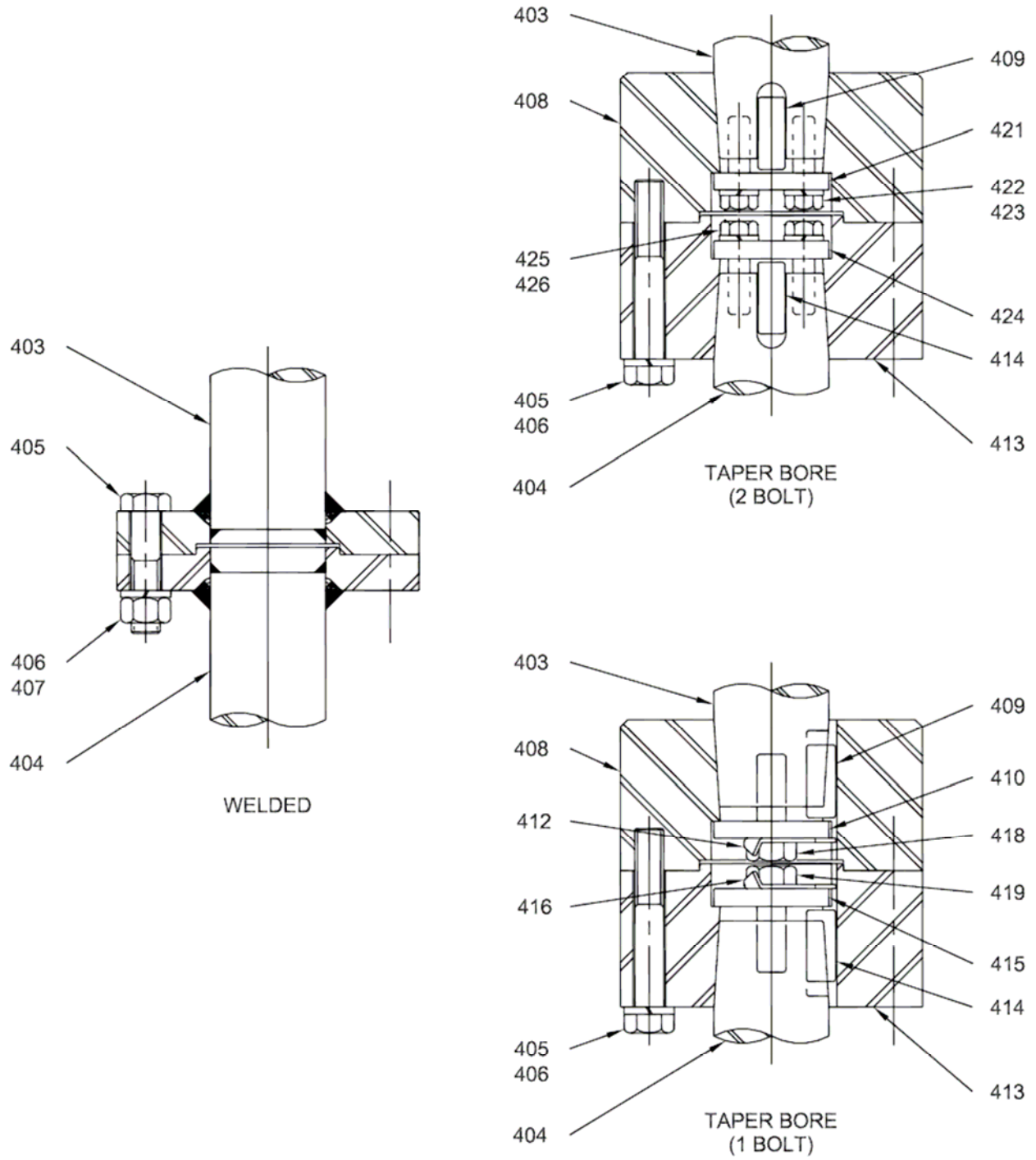

Figure 25A. In-Tank Couplings (Continued)

O.2 STEADY BEARINGS

Model 20 GT/HT agitators may include an optional in-tank steady bearing. See the unit assembly drawing for the steady bearing style, type of mounting, and vessel installation requirements.

Proper steady bearing operation requires the agitator extension shaft to be straight and the steady bearing to be centered on the shaft. Refer [Shaft Runout Section](#), page 32, for checking and straightening the shaft. Steady bearing mountings should be located from the installed agitator extension shaft.

O.2.1 Bracket Steady Bearing

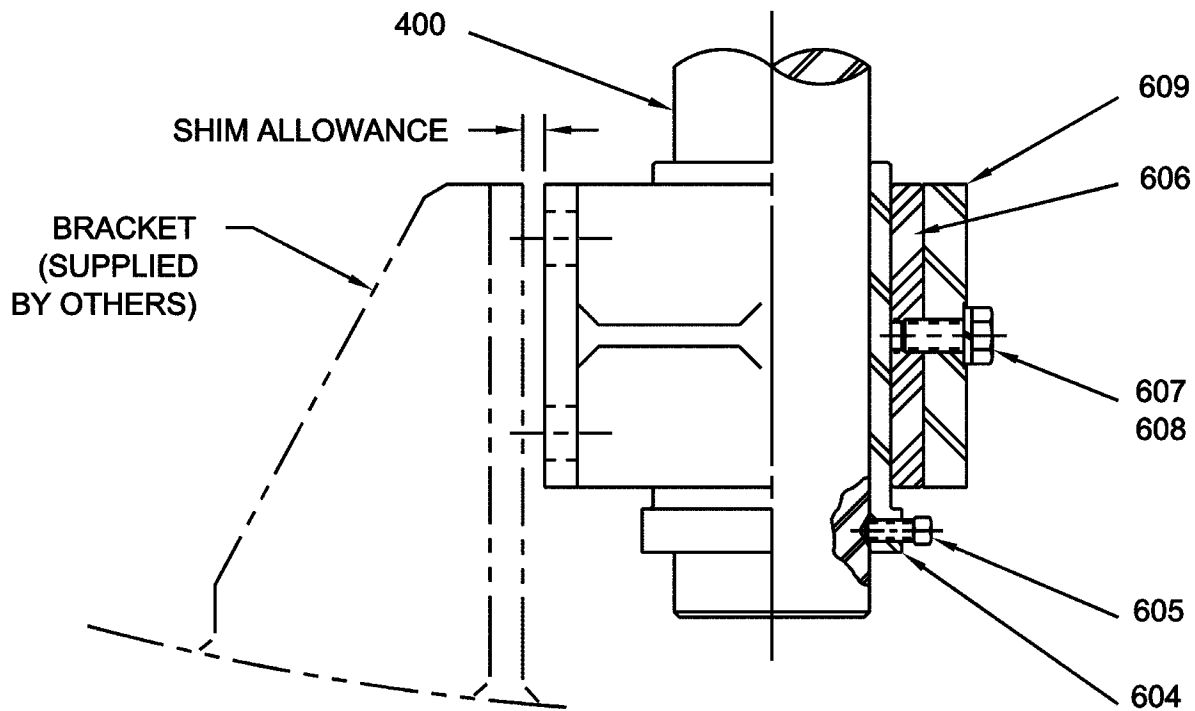

Figure 26. Bracket Steady Bearing

1. Place the steady bearing assembly on the end of the shaft and attach it to the support bracket (supplied by others). The support bracket should be located such that the steady bearing assembly is centered on the shaft. Bolt the steady bearing housing [609] to the support bracket. Tighten the bracket bolts (supplied by others) to 25% of specified torque per the APPENDIX, Page 100.
2. Loosen setscrews [605] and remove wear sleeve [604]. Remove bushing retaining bolt [607] and bushing [606] from steady bearing housing [609].

3. Attach a dial indicator to the shaft and set it so the point of the indicator extends inside the steady bearing-housing bore.
4. Manually turn the gear drive flexible coupling half to rotate extension shaft one turn. Shim the steady bearing housing until it is located concentric to the shaft centerline within .050" (1.25 mm) FIM (Full Indicator Movement).
5. Install bushing, bushing retaining bolt, lockwasher, wear sleeve and setscrews [**606, 607, 608, 604, 605**]. See the unit assembly drawing for the position of the wear sleeve on the shaft. Tighten the bushing retaining bolt and the setscrews.
6. With a feeler gauge check the clearance between the wear sleeve and the bushing at the top and bottom in 90° increments. For proper angular alignment, the gap at all locations (from top to the bottom) must be within .010" (.25 mm) of each other.
7. If the angular alignment needs correction, repeat *Steps 1 through 6*.
8. Once the final steady bearing housing location has been determined, drill the steady bearing housing and its support bracket at two locations and install roll or dowel alignment pins (supplied by others). Torque the bracket bolts to the value shown in the APPENDIX, Page 100.
9. Remove the wear sleeve setscrews one at a time and transfer punch a center into the agitator shaft. Take the wear sleeve off the shaft. Spot the shaft for the setscrews using a drill of the same diameter as the setscrews. Drill to the depth of the drill point.
10. Reinstall the wear sleeve with the setscrews over the drill spots located in Step 9. Torque the setscrews and the bushing-retaining bolt to the value shown in the APPENDIX, Page 100. The tapped holes for the setscrews are usually a self-locking thread form. When an auxiliary fastener locking is required, screws will be drilled and lock-wire will be attached..



CAUTION! *Do not operate the agitator without the steady bearing being submerged.*

O.2.2 Cup Tri-Pod Steady Bearing

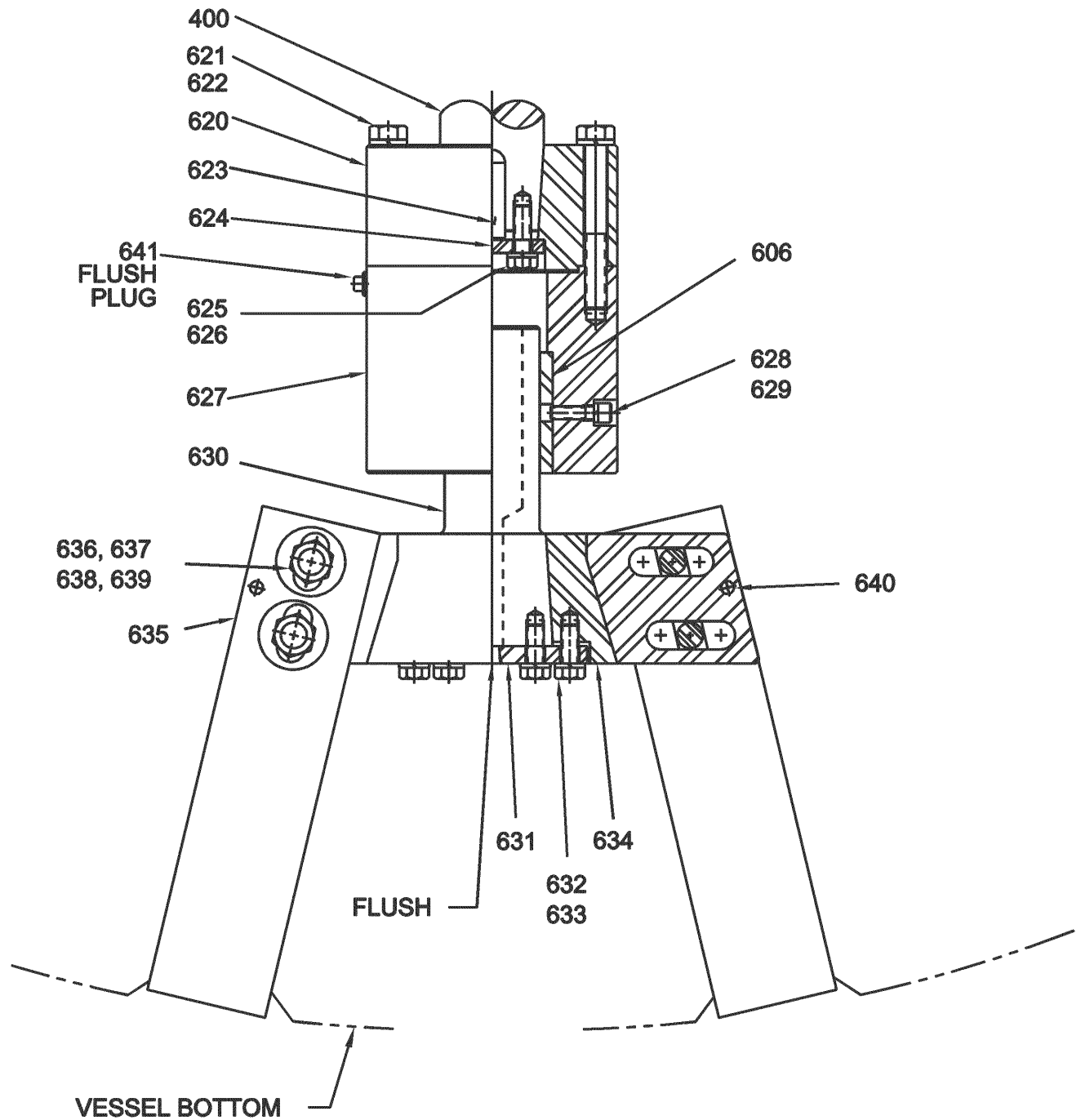

Figure 27. Cup Tri-Pod Steady Bearing

1. Install the coupling [620] onto the end of the extension shaft [400] with key [623] and bolts, lockwashers, and coupling washer [625, 626, 624]. Refer to Installation, page 50 for in-tank coupling installation.
2. Assemble the stub shaft [630], stub shaft housing [634], and retainer plate [631] with bolts [632] and lockwashers [633]. Torque bolts to the value shown in the APPENDIX, Page 100.

NOTE: Be sure to assemble the stub shaft [630] to the retainer plate [631] before inserting into the stub shaft housing [634]. Alignment of the stub shaft [630] to the retainer plate [631] is crucial to future maintenance.

3. Attach legs [635] with bolts, nuts, lockwashers, and two flat washers [636, 637, 638, 639]. Do not torque the bolts at this time. Locate the steady bearing assembly so that it is centered with the extension shaft.
4. Adjust the leg angle and steady bearing assembly height. Torque the leg bolts [636] to value shown in the APPENDIX, Page 100. Refer to the steady bearing assembly drawing for the proper steady bearing set dimensions.

NOTE: Later in the procedure, the stub shaft housing will need to be adjusted for shaft concentricity and parallelism. Be sure to leave room in the leg and housing slots for future adjustment.

5. Attach the legs [635] to the vessel bottom.



CAUTION! *The stub shaft [630] will need to be removed periodically for future maintenance. Be certain that there is no obstruction below the steady bearing assembly that would hinder the stub shaft removal.*

6. Attach an indicator to the coupling [620] and set the point of the indicator on the top of the stub shaft housing [634]. Manually turn the extension shaft [400] one full turn. Loosen the leg bolts [636] and nuts [637] and adjust the stub shaft housing [634] to obtain 0.010" (0.25 mm) FIM (Full Indicated Movement) maximum.
7. Place the indicator point on the outside diameter of the stub shaft [630] and rotate the extension shaft one turn. Loosen the leg bolts [636] and nuts [637] and move the stub shaft housing [634] until the stub shaft is located concentric to the shaft centerline within 0.050" (1.25 mm) FIM.
8. Torque the leg bolts [636] and nuts [637] to the value shown in the APPENDIX, Page 100.
9. Recheck the steady bearing alignment with the dial indicator. If the alignment needs correction, repeat steps 6 through 8.

10. Once the final steady bearing housing location has been determined, drill the stub shaft housing and install the dowel alignment pins [640].
11. Loosen and remove bolts and lockwashers [632, 633] anchoring the retainer plate [631] to the stub shaft housing [634]. Re-install bolts into tapped holes at 90 degrees in the retainer plate. Progressively tighten these bolts around the bolt circle to remove the stub shaft [630] from stub shaft housing.



CAUTION! *Tapers can disengage with a great deal of force. On larger units, the stub shaft/retainer assembly can be very heavy. It may be advantageous to only remove half of the retainer plate to housing bolts and use those removed to break the stub shaft taper as described above. This will allow the stub shaft to still be held in position when it disengages.*

12. Install bushing [606] into bushing housing [627] and secure with bushing retaining bolt [628] and lockwasher [629]. With bushing installed, assemble bushing housing to coupling [620] using bolts and lockwashers [621, 622]. Torque the bolts to the value shown in the APPENDIX, Page 100.
13. Install the stub shaft [630] through the stub shaft housing [634] and into the bushing [606]. Attach the retainer plate [631] with bolts [632] and lockwashers [633]. Torque bolts to the value shown in the APPENDIX, Page 100. The retainer plate has been drilled and tapped for a NPT pipefitting, be sure to orient the plate so that the larger end of the tapped fitting hole is facing downward.
14. The tripod steady bearing has an optional flush feature for lubrication and cooling. If the flush is utilized, attach the flush piping to the flush hole in the retainer plate [631]. Keep the flush plug [641] in place on the bushing housing [627]. Note: The flush inlet pressure should be 15 to 20 psi over the vessel pressure.
15. If the flush is not utilized, remove flush plug [641] from the bushing housing [627].



CAUTION! *Do not operate the agitator without the steady bearing flush on or the steady bearing assembly fully submerged.*

O.2.3 Tri-Pod Steady Bearing

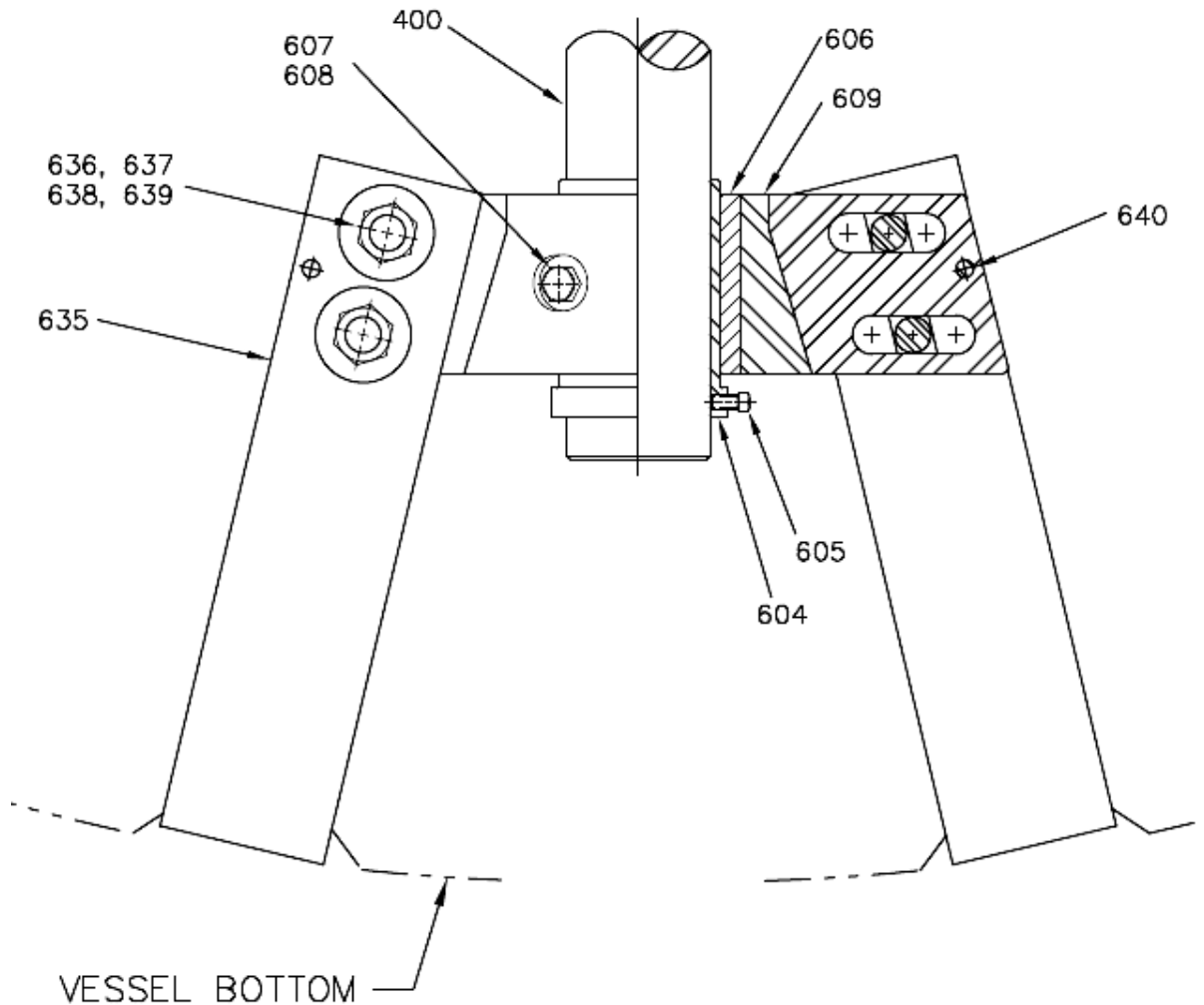

Figure 27A. Tripod Steady Bearing

1. Attach legs [635] with bolts, nuts, lockwashers, and two flat washers [636, 637, 638, 639]. Do not torque the bolts at this time. Locate the steady bearing assembly so that it is centered with the extension shaft [400].
2. Adjust the leg angle and steady bearing assembly height. Torque the leg bolts [636] to value shown in the APPENDIX, Page 100. Refer to the steady bearing assembly drawing for the proper steady bearing set dimensions.

***NOTE:** Later in the procedure, steady bearing housing will need to be adjusted for shaft concentricity and parallelism. Be sure to leave room in the leg and housing slots for future adjustment.*

3. Attach the legs [635] to the vessel bottom.



CAUTION! The wear sleeve [604] and bushing [606] will need to be removed periodically for future maintenance. Be certain that there is no obstruction below the steady bearing assembly that would hinder their removal.

4. Attach a dial indicator to the shaft [400] and set it so the point of the indicator extends inside the steady bearing housing bore [634] and rotate the extension shaft one turn. Loosen the leg bolts [636] and nuts [637] and move the housing [634] until it is located concentric to the shaft centerline within 0.050" (1.25 mm) FIM.
5. Install bushing, bushing retaining bolt, lockwasher, wear sleeve and setscrews [606,607,608, 604, 605]. See the unit assembly drawing for the position of the wear sleeve on the shaft. Tighten the bushing retaining bolt and the setscrews.
6. With a feeler gage, check the clearance between the wear sleeve and the bushing at the top and bottom in 90° increments. For proper angular alignment, the gap at all locations (from top to the bottom) must be within 0.010" (0.25mm) of each other.
7. If the angular alignment needs correction, repeat steps 1-6.
8. Torque the leg bolts [636] and nuts [637] to the value shown in the APPENDIX, Page 100.
9. Recheck the steady bearing alignment with the dial indicator. If the alignment needs correction, repeat steps 6 through 8.
10. Once the final steady bearing housing location has been determined, drill and install the dowel alignment pins [640].
11. Remove the wear sleeve setscrews [605] one at a time and transfer punch a center into the agitator shaft [400]. Take the wear sleeve [604] off the shaft. Spot the shaft for the setscrews using a drill of the same diameter as the setscrews. Drill to the depth of the drill point.
12. Reinstall the wear sleeve [604] with the setscrews [605] over the drill spots located in the previous step. The tapped holes for the setscrews are usually a self-locking thread form; auxiliary fastener locking is not necessary. Torque the bolts to the value shown in the APPENDIX, Page 100. When auxiliary fastener locking is required, screws will be drilled and lock-wire will be attached.



CAUTION! Do not operate the agitator without the steady bearing assembly fully submerged.

O.2.4 Pad Steady Bearing

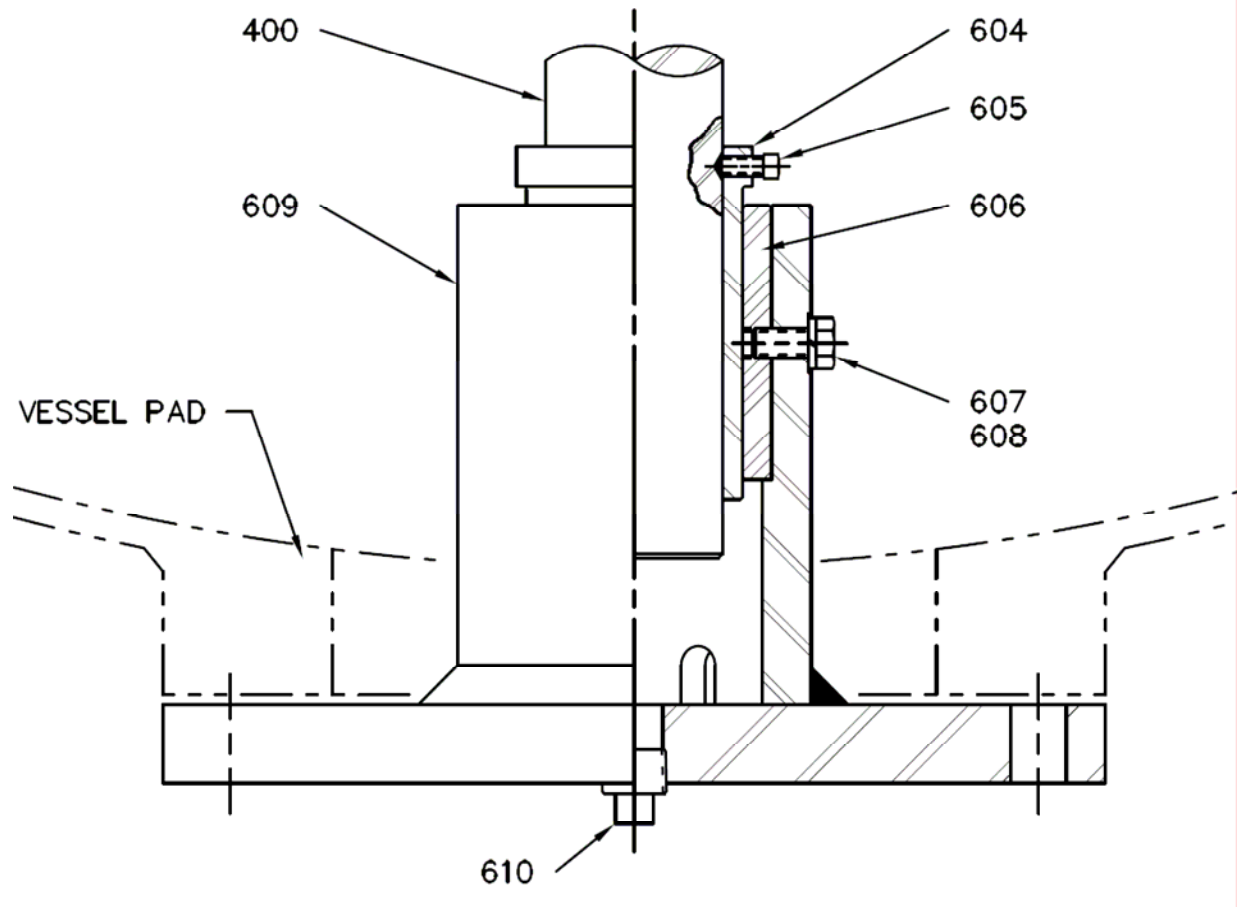

Figure 27B. Pad Steady Bearing

1. Assemble steady bearing housing [609] to the vessel pad with the proper gasket and flange bolts (supplied by others). Tighten the flange bolts to 25% of specified torque shown in the APPENDIX, Page 100.
2. Slide wear sleeve [604] up the extension shaft to disengage from bushing [606].
3. Attach a dial indicator to the shaft and set the point of the indicator on the top face of housing hub [609].
4. Manually turn the flexible motor coupling to rotate the extension shaft one turn. If the runout exceeds .010" (0.25 mm) FIM (Full Indicator Movement) maximum, a tapered adapter (supplied by others) should be installed between the housing mounting flange and the vessel mounting pad. Call Chemineer Field Service for assistance.
5. Place the indicator point on the outside diameter of the housing hub and rotate the extension shaft one turn. Loosen the flange bolts and move the steady bearing housing

until it is located concentric to the shaft centerline within .050" (1.27 mm) FIM. Torque the flange bolts to the value shown in APPENDIX, Page 100.

6. In extreme cases, the agitator drive may have to be shimmed to correct for angular misalignment. Call Chemineer Field Service for assistance.
7. If the angular alignment needs correction, repeat the previous steps.
8. Once the final steady bearing housing location has been determined, drill the steady bearing housing flange at two locations on or outside of the bolt circle and install roll or dowel alignment pins (supplied by others).
9. Slide the wear sleeve down the shaft into the bushing. See the unit assembly drawing for the position of the wear sleeve on the shaft. Tighten setscrews [605].
10. Remove the wear sleeve setscrews one at a time and transfer punch a center into the agitator shaft. Slide the wear sleeve up the shaft and retain. Spot the shaft for the setscrews using a drill of the same diameter as the setscrews. Drill to the depth of the drill point.



CAUTION! *Cover the opening between the extension shaft and the bushing to prevent drill chips from getting into the housing.*

11. Reinstall the wear sleeve with the setscrews over the drill spots located in *Step 10*. Torque the setscrews to the value shown in APPENDIX, Page 100. The tapped holes for the setscrews are a self-locking thread form. Auxiliary fastener locking is not necessary.



CAUTION! Do not operate the agitator without the steady bearing assembly fully submerged.

O.3 ANCHOR BOLTS

Anchor bolts [901] are to be located on centers as specified on the unit assembly drawing or Figure 2A on page 13 or Figure 2B on page 14. Mount the agitator drive on the anchor bolts and install flatwashers, lockwashers and nuts [904, 903, 902]. Torque bolts to the value shown in the APPENDIX, Page 100.

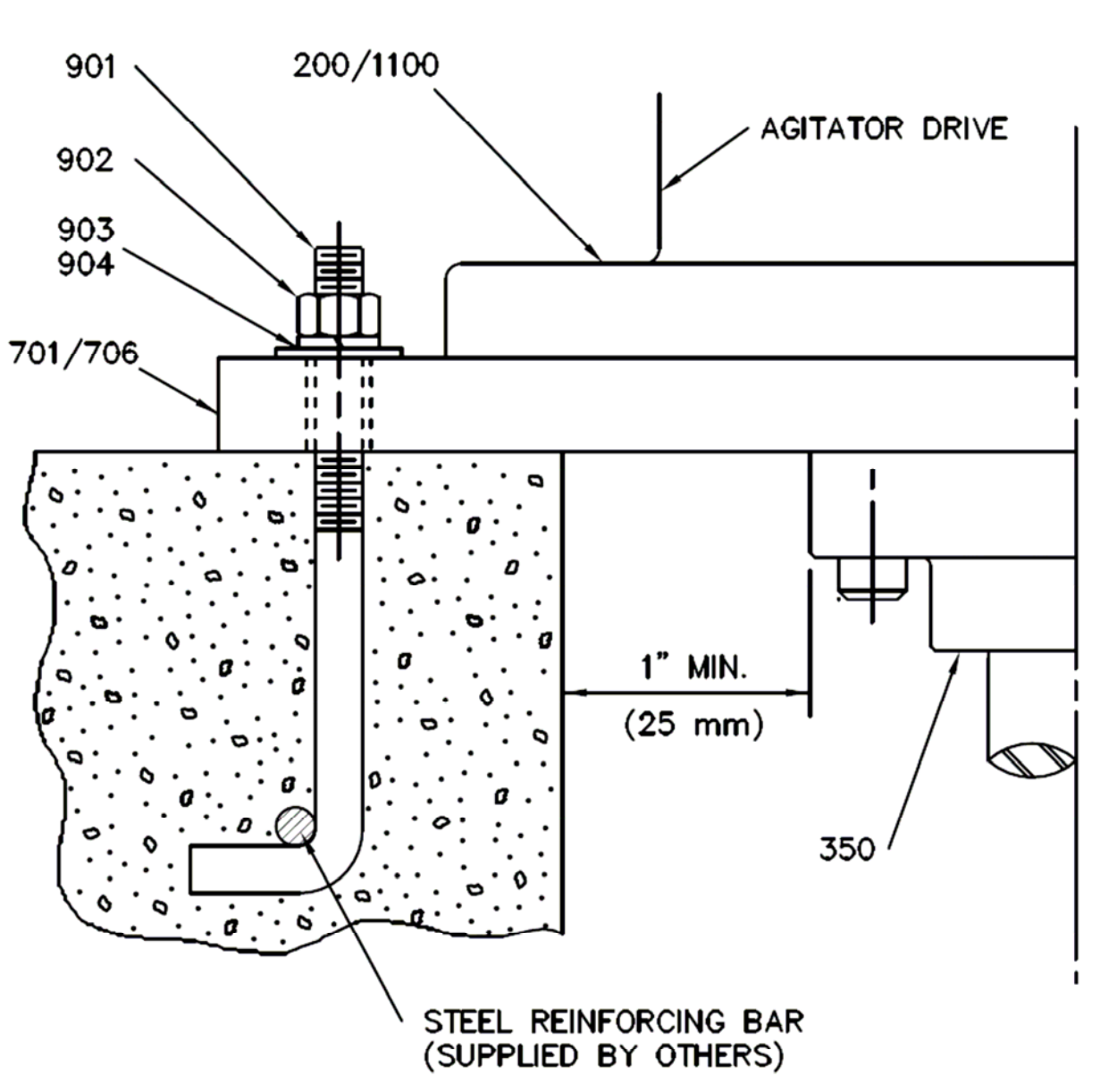

Figure 28. Anchor Bolt Assembly

P. LUBRICATION

This section defines the proper oils and greases that must be used with this equipment.



CAUTION! Check the gear drive for proper oil fill before operating.

P.1 MOTOR - LUBRICATION

The motor bearings are properly greased by the manufacturer. Motor bearings should be re-greased at 12-month intervals when installed in clean, dry environments, or every six months for heavy duty and dusty locations. Any good quality general-purpose grease consisting of a refined base oil stock and a lithium, calcium, or polyurea (preferred) complex based soap, with an NLGI No. 2 classification, will work satisfactorily. **However, different greases are not always compatible. Hence, check for compatibility of greases before you replace one with the other.** Most major oil companies offer such products, usually with extreme pressure (EP) additives for additional protection. Table 7, page 64 lists some commonly available greases.

When re-greasing, stop the motor, remove the outlet plug and add grease according to motor supplier's recommendations with a hand lever gun only. Run the motor for about ten minutes before replacing the outlet plug. Certain TEFC motors have a spring relief outlet fitting on the fan end. If the outlet plug is not accessible at the surface of the hood, it is the spring relief type and need not be removed when re-greasing.



CAUTION! Over-greasing is a major cause of bearing and motor failure.

The following actions can be taken to correct or prevent motor over-greasing and related problems¹:

1. Review motor lubrication procedures to ensure that they identify the type and quantity of grease to use, the specific fill and drain nozzles to uncap, and the length of time motors should be run with drain plugs off after greasing the bearings.
2. To prevent foreign materials from contaminating the grease, ensure that grease containers are covered during periods of storage and that the nozzles and grease fittings are cleaned.
3. Determine the optimum quantity and correct type of grease required for each motor by examining the manufacturer's recommendations and by monitoring the behavior of grease added to motors.
4. Consider using pre-lubricated sealed bearings in applications where re-lubrication is difficult, where contaminants can adulterate the grease, or where over-greasing might damage safety systems.

¹US Nuclear Regulatory Commission, Information Notice No. [88-12](#)

Table 7. TYPICAL NLGI NO. 2 GREASES

<i>For Ambient Temperature Range of 0° to 150° F (-18° to 66° C)</i>		
MANUFACTURER	GENERAL PURPOSE	EP
BP oil co.		Energrease LS-EP Grade 2
Chevron U.S.A.Inc.	Chevron SRI grease Grade 2	Dura-Lith greases EP: Grade 2
Conoco Inc.		EP Conolith grease: Grade 2
Exxon Co. U.S.A.	Unirex N: Grade 2	Nebula EP: Grade 2
		Ronex MP: Grade 2
Mobil Oil Corp.	Mobilith AW Grade 2	Mobilux EP 2
Phillips 66 Co.		Philube EP grease: EP-2
Shell Oil Co.	Alvania RL grease: Grade 2	Alvania grease EP LF 2
Texaco Lubricants Co.	Polystar RB 2 grease	Multifak EP 2
Unocal 76		Unoba EP grease: Grade 2
		Multiplex Red EP: Grade 2

P.2 GEAR DRIVE - LUBRICATION

For GT Gear Drives:

The gear drive features oil bath lubrication for all gears and all bearings except [233, 245]. Refer to either Figure 30, page 72 for double reduction units or Figure 31, page 73 for triple reduction units. The lubrication is identical for double and triple GT units.

For HT Gear Drives:

The gear drive features oil bath lubrication for all gears and all bearings except [233, 245, 203, 217]. Refer to Figure 32, page 74 for spiral bevel unit.



CAUTION! *The gear drive has been drained of oil for shipping. Fill gear drive with oil prior to operating!*

See Table 10, page 68 for operating oil capacity.

Always use new oil to avoid damage to the gearing or bearings. When checking oil level, the agitator must be shut off. Remove the breather-dipstick [258] and add oil until the level is between the “max” and “min” marks on the dipstick [258]. The Dipstick must be fully installed into the lid for a proper level reading.



CAUTION! *Do not over or under fill the gear drive.*

Do not operate before filling with oil. Re-install the breather-dipstick [258].

The agitator nameplate or Table 9, page 68, should be used to select the proper viscosity oil based on ambient temperature conditions. Table 10 should be used as a guide to determine the quantity of oil required.

Use good quality straight grade, R & O petroleum base gear oil per Table 11, page 69 for most applications. If the gear drive loading is extremely heavy or if ambient temperature exceeds 100°F (38°C), an EP oil per Table 12, page 70 should be used. In general, EP oil will be beneficial for all operating conditions. Table 11 and Table 12 are presented for guidance and equivalent oils from other suppliers may be used.

For very heavily loaded units, or units running in very high ambient temperatures, synthetic lubricants may be necessary. The gearbox nameplate and the customer drawings will state this. Table 13 provides guidance on synthetic lubricants.

Food grade lubricants, if necessary, are to be specified by the customer. Generally, the lubricant supplier can provide FDA approved equivalents to those listed in the above mentioned tables.

Drain oil by removing drain plug [264] and refill the gear drive after the first week or 100 hours of operation, and then every six months or 2500 hours thereafter. If operated in adverse conditions such as an extremely dusty or humid environment, more frequent oil changes are advisable.

For GT Gear Drives:

Bearings [233, 245] are grease lubricated. These bearings are packed with grease prior to shipment from the factory. At 3 month intervals, bearings [233] and [245] should be re-greased. Remove pipe plug [261] from output cap [254] and pump grease into grease fitting [260] until new grease appears at the pipe plug hole. Re-install the pipe plug [261]. Remove pipe plug [263] and pump approximately the same amount of grease into grease fitting [262] that was pumped into grease fitting [260]. Re-install the pipe plug [263].

For HT Gear Drives:

Bearings [233, 245, 203, 217] are grease lubricated. These bearings are packed with grease prior to shipment from the factory. At 3 month intervals, bearings [233] and [245] should be re-greased. Remove pipe plug [261] from output cap [254] and pump grease into grease fitting [260] until new grease appears at the pipe plug hole. Re-install the pipe plug [261]. Remove pipe plug [263] and pump approximately the same amount of grease into grease fitting [262] that was pumped into grease fitting [260]. Re-install the pipe plug [263].

Pump grease in [203] and [217] using grease fittings [384] and [385], as per the volume indicated in Table 8, page 66.

Table 8. MODEL 20 HT INTERMEDIATE BEARING GREASE ADDITION

GEAR DRIVE SIZE	At [203]		At [217]	
	in ³	cm ³	in ³	cm ³
21 HT	0.6	10	1.3	22
22 HT	1.2	20	2.6	44
23 HT	2.4	40	5.2	88

Other bearings in the gear drive are oil bath lubricated and do not require any greasing. Any good quality general-purpose grease consisting of a refined base oil stock and a lithium or calcium-complex based soap with a NLGI No. 2 classification will work satisfactorily. Most major oil companies offer such products usually with extreme pressure (EP) additives for additional protection. Table 7, page 64 lists some commonly available grease.

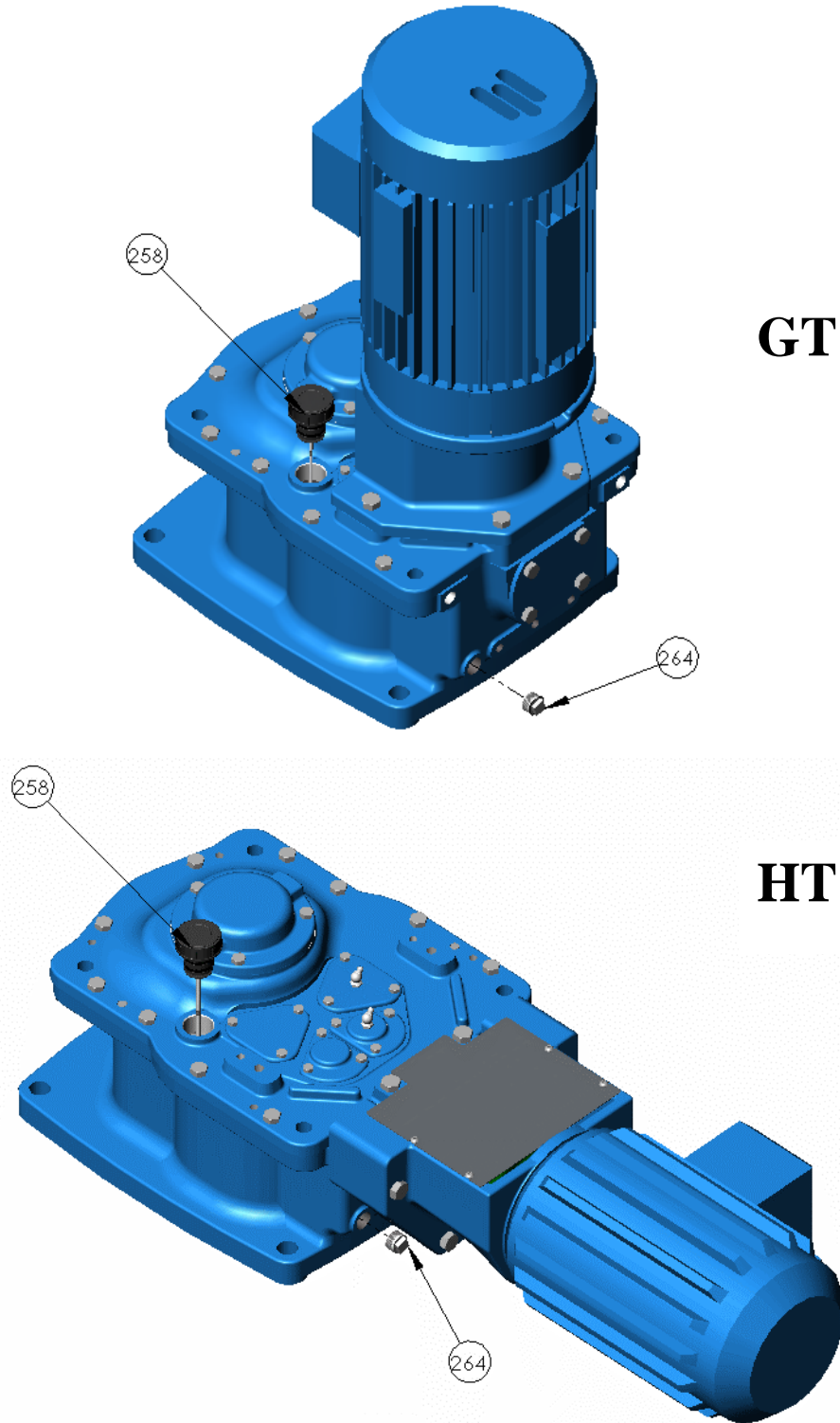

Figure 29. Model 20 GT/HT Gear Drive Oil Level Dipstick

Table 9. LUBE OIL SELECTION

Ambient Temperature	ISO Viscosity Grade	AGMA Lubricant Number
-10° to 15°F (-24° to -10°C)	32 to 68	Up to 2
15° to 50°F (-10° to 10°C)	100 to 150	3 to 4
50° to 125°F (10° to 50°C)	220 to 320	5 to 6

NOTE: For low temperature operation, the oil selected should have a pour point at least 9°F or 5°C below the expected ambient temperature and a viscosity which is low enough to allow the oil to flow freely at start up temperature.

Table 10. APPROXIMATE OPERATING OIL CAPACITY

MODEL	TYPE	QUARTS	GALLONS (US)	LITRES
21	GT	4.4	1.1	4.2
	HT	2.4	0.6	2.3
22	GT	8.0	2.0	7.6
	HT	4.8	1.2	4.6
23	GT	20	5	19
	HT	14	3.5	13.3

NOTE: Remove the pipe plug [267] while filling oil. Fill up to the level mark on the dipstick or until the oil just overflows from the pipe plug [267] hole. (See Figure 30 on page 72, Figure 31 on page 73, and Figure 32 on page 74)

Table 11. TYPICAL RUST & OXIDATION INHIBITED (R&O) LUBE OILS

AGMA Lubricant Number	1	2	3	4	5	6	7
ISO Viscosity Grade	46	68	100	150	220	320	460
Viscosity Range (cSt) @ 104° F (40° C)	41.4 to 50.6	61.2 to 74.8	90 to 110	135 to 165	198 to 242	288 to 352	414 to 506
Manufacturer	Lubricant	Lubricant	Lubricant	Lubricant	Lubricant	Lubricant	Lubricant
BP Oil Co.	Energol HLP-HM 46	Energol HLP-HM 68	Energol HLP-HM 100	Energol HLP-HM 150	Energol HLP-HM 220	Energol HLP-HM 320	Energol HLP-HM 460
Chevron U.S.A., Inc.	Hydraulic Oil AW 46	Hydraulic Oil AW 68	Machine Oil AW 100	Machine Oil AW 150	Machine Oil AW 220	Machine Oil AW 320
CITGO Petroleum Corp.	Citgo Pacemaker 46	Citgo Pacemaker 68	Citgo Pacemaker 100	Citgo Pacemaker 150	Citgo Pacemaker 220	Citgo Pacemaker 320	Citgo Pacemaker 460
Exxon Co., U.S.A.	Teresstic 46	Teresstic 68	Teresstic 100	Teresstic 150	Teresstic 220	Teresstic 320	Teresstic 460
Mobil Oil Corp	DTE Oil Medium	DTE Oil Heavy Medium	DTE Oil Heavy	DTE Oil Extra Heavy	DTE Oil BB	DTE Oil AA
Phillips 66 Co.	Magnus Oil 46	Magnus Oil 68	Magnus Oil 100	Magnus Oil 150	Magnus Oil 220	Magnus Oil 320
Shell Oil Co.	Turbo T 46	Turbo T 68	Morlina 100	Morlina 150	Morlina 220	Morlina 320	Morlina 460
Texaco Lubricants Co.	Regal Oil R & O 46	Regal Oil R & O 68	Regal Oil R & O 100	Regal Oil R & O 150	Regal Oil R & O 220	Regal Oil R & O 320	Regal Oil R & O 460

Table 12. TYPICAL EXTREME PRESSURE (EP) LUBE OILS

AGMA Lubricant Number	2 EP	3 EP	4 EP	5 EP	6 EP	7 EP
ISO Viscosity Grade	68	100	150	220	320	460
Viscosity Range (cSt) @ 104° F (40° C)	61.2 to 74.8	90 to 110	135 to 165	198 to 242	288 to 352	288 to 352
Manufacturer	Lubricant	Lubricant	Lubricant	Lubricant	Lubricant	Lubricant
BP Oil Co.	Energol GR-XP 68	Energol GR-XP 100	Energol GR-XP 150	Energol GR-XP 220	Energol GR-XP 320	Energol GR-XP 460
Chevron U.S.A., Inc.	Gear Compounds EP 68	Gear Compounds EP 100	Gear Compounds EP 150	Gear Compounds EP 220	Gear Compounds EP 320	Gear Compounds EP 460
CITGO Petroleum Corp.	EP Compounds 68	EP Compounds 100	EP Compounds 150	EP Compounds 220	EP Compounds 320	EP Compounds 460
Exxon Co., U.S.A.	Spartan EP 150	Spartan EP 220	Spartan EP 320	Spartan EP 460
Mobil Oil Corp	Mobilgear 626	Mobilgear 627	Mobilgear 629	Mobilgear 630	Mobilgear 632	Mobilgear 634
Phillips 66 Co.	All Purpose Philgear 68	All Purpose Philgear 100	All Purpose Philgear 150	All Purpose Philgear 220	All Purpose Philgear 320	All Purpose Philgear 460
Shell Oil Co.	Shell Omala 68	Shell Omala 100	Shell Omala 150	Shell Omala 220	Shell Omala 320	Shell Omala 460
Texaco Lubricants Co.	Meropa 68	Meropa 100	Meropa 150	Meropa 220	Meropa 320	Meropa 460

Table 13. TYPICAL SYNTHETIC LUBE OILS

AGMA Lubricant Number	2	4	5	6
ISO Viscosity Grade	32	68	150	220	320
Ambient Temperature Range °F	-30 to +10	-15 to +50	0 to +80	+10 to +125	+20 to +125
Viscosity Range (cSt) @ 104° F (40° C)	61.2 to 74.8	61.2 to 74.8	135 to 165	198 to 242	288 to 352
Manufacturer	Lubricant	Lubricant	Lubricant	Lubricant	Lubricant
Chevron U.S.A., Inc.	Tegra 150 *	Tegra 220 *	Tegra 320 *
CITGO Petroleum Corp.	Pacemake ST 32
Mobil Oil Corp	SHC 624	SHC 626	SHC 629	SHC 630	SHC 632
	Mobilgear SHC 150 *	Mobilgear SHC 220 *	Mobilgear SHC 220 *

* Extreme pressure EP lubricants (contains sulfur, phosphorus)

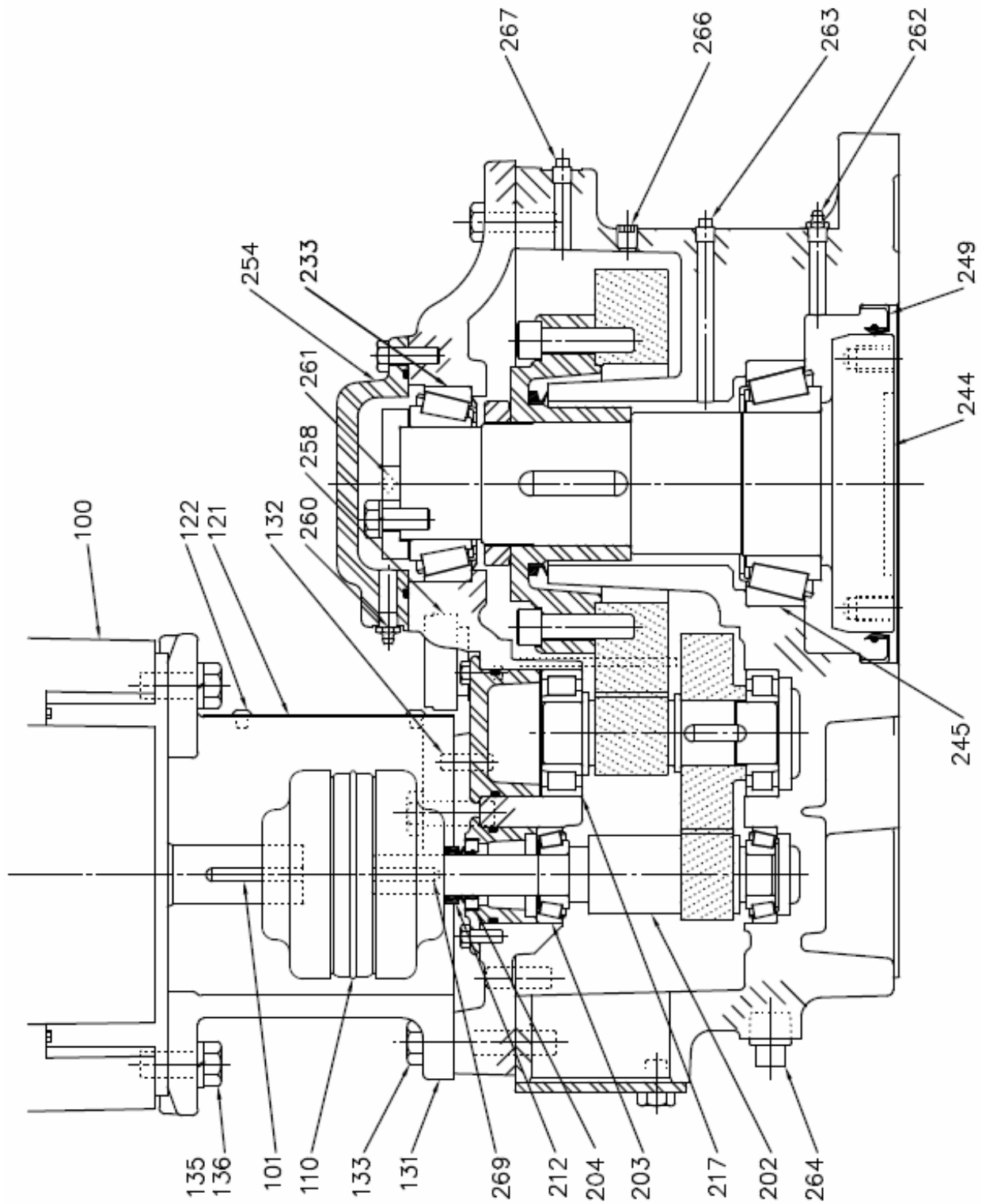

Figure 30. Model 20 GT Double Reduction Gear Drive

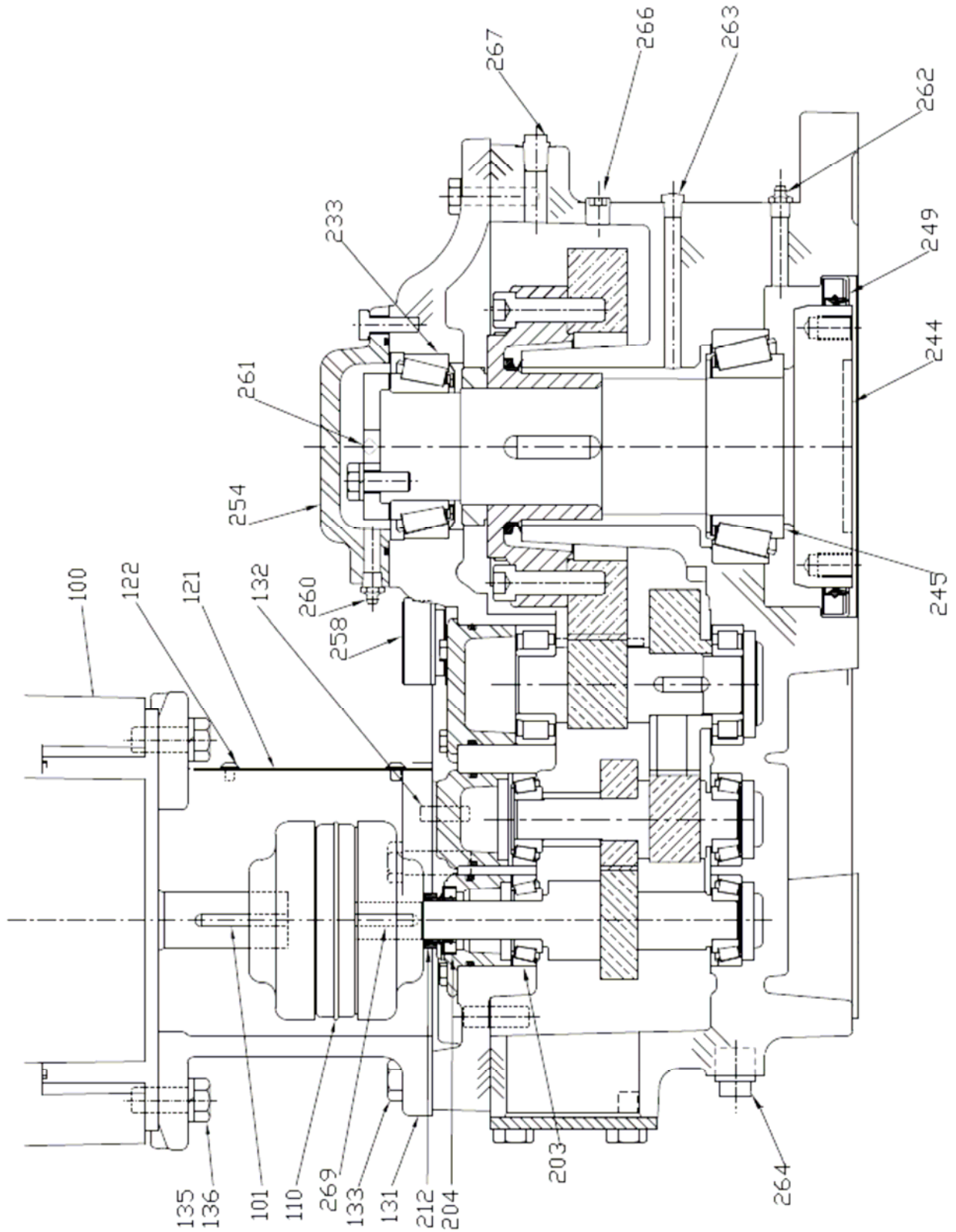

Figure 31. Model 20 GT Triple Reduction Gear Drive

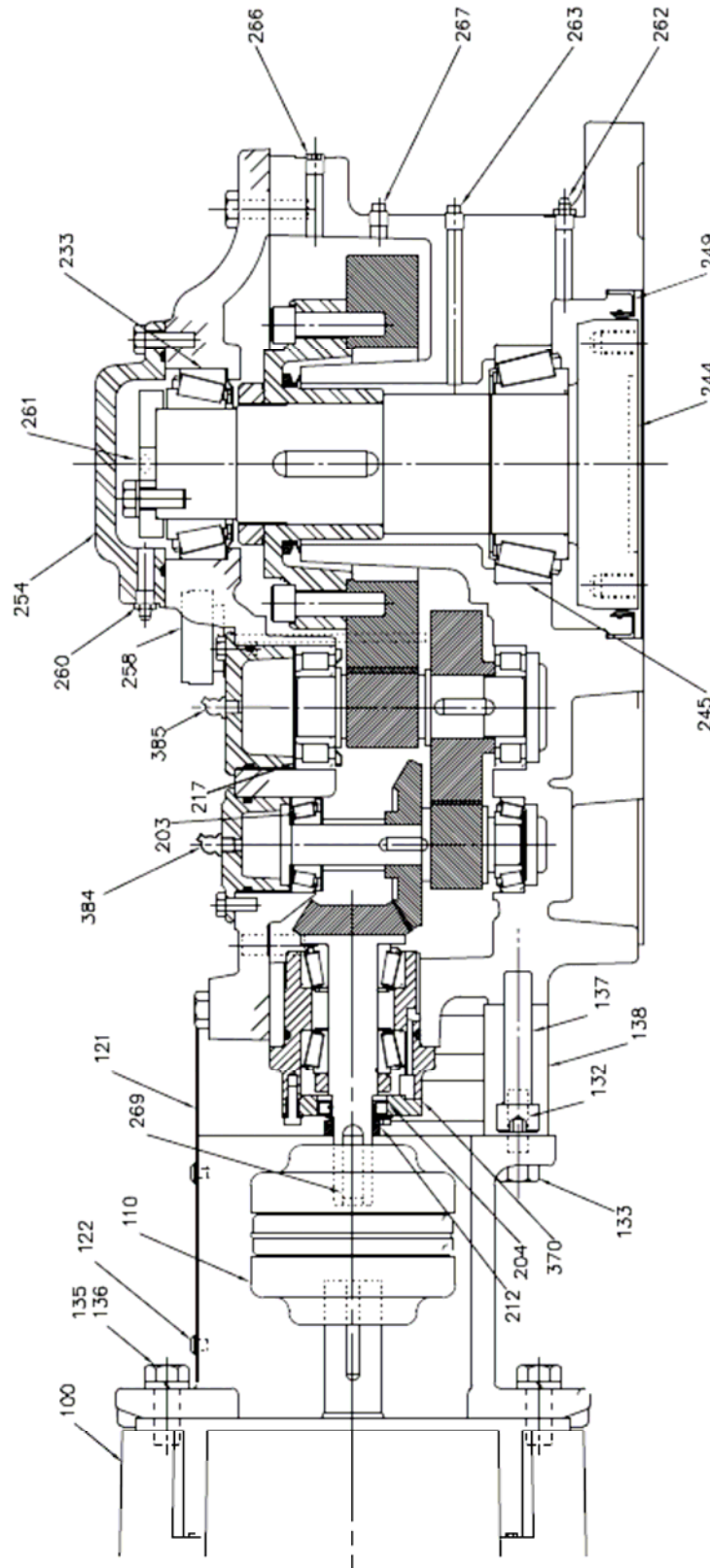

Figure 32. Model 20 HT Gear Drive

P.3 SHAFT SEALS - LUBRICATION

Some units are furnished with auxiliary mounted stuffing boxes with six rings of self-lubricating packing. This packing does not require any additional lubrication for the life of the packing. Please refer to agitator assembly drawings for seal style and packing type.

P.4 STEADY BEARINGS - LUBRICATION

Steady bearings are lubricated and cooled by the process fluid. Do not operate agitator unless the steady bearing is submerged or there is a flush to the steady bearing.

If a Clean-In-Place (CIP) system is present, it will generally put enough liquid into the steady bearing to ensure the bearing is adequately lubricated.

Q. OPERATION

Q.1 AGITATOR OPERATION

Chemineer agitator has been designed for your specific application. Proper operating procedures will allow maximum performance.



The following list will aid in the safe operation of your unit.

- **Do not** operate the unit before reading and following the instructions on all tags and nameplates attached to the unit.
- **Do not** operate the unit in a fluid with a specific gravity or viscosity higher than that for which the unit was designed.
- **Do not** attempt to start a unit with the mixing impeller buried in solids or a "set up" fluid.
- **Do not** operate mechanical shaft seals at temperatures or pressures higher than those for which the unit was designed. Refer to unit assembly drawing.
- **Do not** locate large pump discharges, other agitators, down comers, coils, baffles, or other vessel internals close to the agitator impellers and extension shaft.
- **Do not** make any changes in the field (i.e. motor horsepower, agitator speed, shaft length, impeller diameter, impeller blade width, etc.) without reviewing the change with your local Chemineer office or Chemineer Field Service. Minor changes could upset the dynamics and result in dramatic and potentially dangerous failures.

Should there be problems operating the unit; review the installation and the [Troubleshooting Guide](#), Table 14, page 81. If you are unable to resolve the problem, contact your [local Chemineer office](#).

Q.2 MOTOR - OPERATION

Electric motors furnished on Chemineer agitators are designed to deliver their rated output when properly installed and maintained.

Air circulation is very important to get full performance and long life from an electric motor. Do not block the suction inlets on fan-cooled motors. Life of the motor will be decreased if its temperature exceeds its thermal rating. The allowable temperature is stamped on the motor nameplate.



Prior to permanently wiring the electric motor:

- Check nameplate data on motor to assure that the available power supply agrees with the motor requirements. Protective devices should be the proper size and rating to safely carry the load and to interrupt the circuit on overloads.
- If motor has been stored in a damp location, the windings may require drying.

NOTE: *Do not obstruct the normal flow of ventilating air through or over the motor.*

Identify motor auxiliary devices such as space heaters or temperature sensors. Connect them in proper circuits and insulate them from motor power cables.

- Check motor leads with connection diagrams on motor nameplate and/or conduit box so that the proper connections are made. All motors should be installed in accordance with the National Electric Code and local requirements.
- Check the gear drive output shaft rotation against the proper rotation indicated on the unit nameplate. For standard three-phase electric motors, the rotation can be reversed by switching any two power leads.
- Check operating motor amperage against motor nameplate amperage.

The motor should start quickly and run smoothly. If the motor should fail to start or make abnormal noise, immediately shut motor off, disconnect it from the power supply, and investigate the cause. If the problem cannot be corrected, contact your [local Chemineer office](#) for assistance.

Q.3 FLEXIBLE MOTOR COUPLING

The standard flexible motor couplings will provide years of operation with very few problems. If the motor is removed for service, the coupling should be inspected for wear. Also, inspect the coupling during every shutdown and whenever undesired noise or vibration occurs.

Q.4 GEAR DRIVE - OPERATION

Gearing and most bearings are oil lubricated. Be sure the gear drive has been filled with the proper amount and type of oil before operation. Refer to the [Lubrication](#) section of this manual. Improper lubrication will result in damage to gearing and bearings in a very short time.

The gear drive should be installed in an unobstructed area with ample air circulation. The gear drive will commonly operate at temperatures of 125° to 175°F (52° to 80°C). Do not be alarmed if the surface of the gear drive feels extremely hot to the touch. The gear drive surface temperature should not exceed 190°F (88°C). If a temperature greater than 190°F (88°C) exists anywhere on the gear drive housing, review the installation for unusually high ambient, poor air circulation, or unusual conditions. If the conditions cannot be improved, synthetic lubrication is an option since it will typically lower the temperature of the gearbox. Consult Chemineer Field Service for advice on this matter.

Q.5 SHAFT SEALS - OPERATION

Q.5.1 LIP SEALS

This gearbox is sealed on the input by a lip seal [204], protected by a v-ring seal [212]. The output shaft [244] is also protected by a single lip seal [249]. These seals are greased at the factory, so no service is necessary at start up for these seals.

The extension shaft lip seal or v-ring does not come pre-greased. While it is not mandatory to grease these seals, the seals will have a lower running temperature and thus a longer life if grease is applied prior to operation. If the process conditions allow, process-compatible grease should be applied to the sealing surface.

All rotary lip seals will eventually need replacement as they are wearing components. Wear rates depend on agitator input and output speeds, frequency of service, and environmental factors. A “typical” life cannot be predicted, so periodic inspection is highly recommended.

Q.5.2 AUXILIARY STUFFING BOXES

Some units are furnished with auxiliary mounted stuffing boxes. The standard stuffing box is a six (6) ring design with self-lubricating packing suitable for 100 psig (689 kPa) at 400°F (204°C).

At start-up, the packing should be “run-in” by tightening the hex adjusting nut one flat at a time, allowing 15 minutes between each take-up for the packing to reseal itself before further tightening. Repeat these adjustments at 15-minute intervals until the desired leakage is obtained.

Make periodic inspections for leakage, but do not pick up the gland unless necessary. Over tightening wears out packing prematurely, and causes scoring and damage to the shaft.

Q.6 STEADY BEARINGS - OPERATION

If a steady bearing is supplied, do not operate agitator unless it is properly installed. Failure to install a required steady bearing will cause severe damage to the agitator assembly if operated. Do not operate agitator unless the steady bearing is submerged.

The tripod and cup-tripod steady bearings have been supplied with an optional flush feature for lubrication and cooling. If the flush is utilized, the pipe plug [641] must remain installed on the bushing housing [627] and the inlet pressure should be maintained at 15 to 20 psi over the vessel pressure. If the flush is not utilized, the pipe plug [641] must be removed.

Q.7 TROUBLE-SHOOTING

Table 14. TROUBLE-SHOOTING GUIDE

OBSERVATION	POSSIBLE CAUSE	ACTION
Noisy Operation	Worn or damaged parts	Check bearings and gears for excessive wear. Replace worn parts. Try to find cause of wear. Check for water and/or abrasives in oil, overload, incorrect rotation, excessive shock, etc.
	Overloading	Overloading can cause excessive separation of gear teeth and loud operation. Check process fluid (specific gravity and viscosity) vs. design conditions. Check agitator speed and impeller diameter against unit assembly drawing information.
	Worn or improperly installed flexible couplings	Couplings can generate noise, which seems to emanate from gear drive. Check for worn parts.
	Structural vibration and sound amplification	Steel mounting structures often amplify small amounts of normal noise into excessive noise. This can be corrected by adding stiffness or sound deadening material to the structure.
Abnormal Heating	Incorrect Oil	Review Lubrication section of manual. Replace with proper oil.
	Unusual ambient	Units installed in a hot area of a plant where airflow is restricted can overheat. Remove obstruction and if necessary force circulate air.
	Improper oil level	Add or remove oil.
	Cleanliness	Remove dirt and/or product buildup from motor/gear drive.
Leaking	Worn oil seals	Replace defective seals.
	Plugged breather	Clean or replace breather.
	Oil in Drywell	Remove relief fitting [263] and drain drywell. Grease the bearing and replace pipe plug.

R. MAINTENANCE –AUXILIARY SEALS

R.1 MAINTENANCE – INTEGRAL-TO-FLANGE STUFFING BOX

The stuffing box is furnished with self-lubricating packing. It does not require any additional lubrication for the life of the packing. Routine maintenance consists of periodic inspections for leakage and tightening of gland nuts [1353]. Repacking is required when satisfactory control over leakage is not attainable.

R.1.1 Stuffing box Removal



CAUTION! Prior to removing the agitator drive, review the agitator installation to assure that all safety issues are resolved.

1. Lock out and disconnect all power to the gear drive motor and optional devices.
2. Depressurize and ventilate vessel.
3. Remove stuffing box packing:

Remove hex adjusting nuts [1353] and lock washers [1354]. Slide gland plate [1355] toward the gear drive. Remove split gland [1356]. With packing tools (supplied by others), remove three rings of packing [1357], lantern ring [1358], and the remaining three rings of packing. The lantern ring is provided with two #8-32 tapped holes to aid in removal.



CAUTION! Never add new packing on top of the old packing, as this will cause accelerated wear and scoring of the shaft.

Refer to the unit assembly drawing for the number and composition of the packing rings supplied originally with your agitator.

R.1.2 Stuffing box repacking

1. Install three packing rings [1357], lantern ring [1358], three more packing rings, split gland [1356] (holes at top), gland plate [1355], lockwashers [1354] and gland nuts [1353]. Stagger each packing split 90°. Seat each packing ring as it is installed.
2. Tighten the gland nuts until the lockwashers are compressed. Let the packing set for five to ten minutes so that it can cold flow and adjust to the gland pressure. Loosen the hex adjusting nuts, then finger tighten.

The stuffing box will require adjustment at start-up. Always strive for satisfactory sealing with the least gland force possible. Tighten the hex adjusting nuts uniformly and gradually (no more than one flat on the nuts every 15 minutes) until the leakage rate is acceptable. Do not over tighten. Make sure the split packing gland remains square with the shaft. Once the

packing has been "run in", the hex adjusting nuts should be retightened on a regular basis. This can vary from weekly to monthly depending upon the desired level of sealing and the frequency of operation.

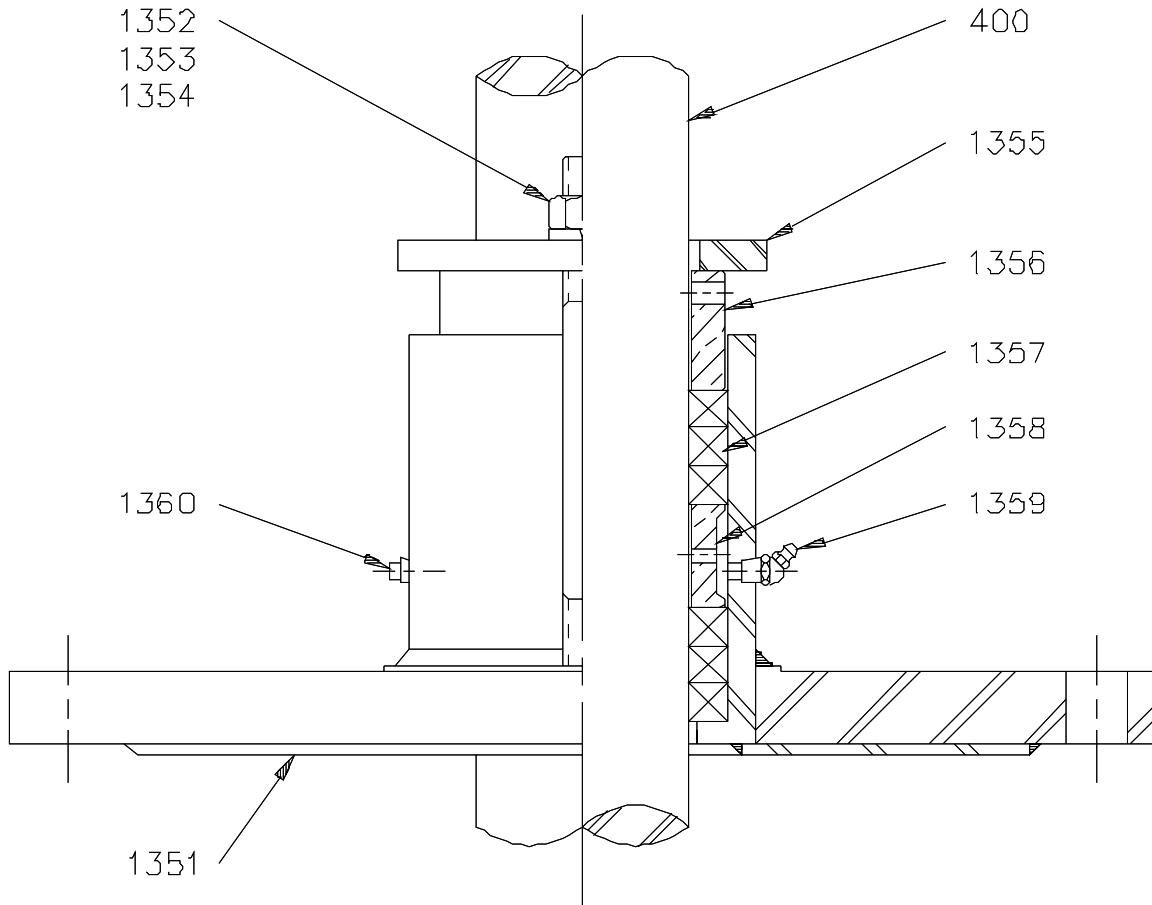

Figure 33A. Auxiliary Stuffing Box

R.2 MAINTENANCE – BOLT-ON STUFFING BOX (CAST HOUSING)

The stuffing box is furnished with self-lubricating packing. It does not require any additional lubrication for the life of the packing. Routine maintenance consists of periodic inspections for leakage and tightening of hex adjusting nuts [1301]. Repacking is required when satisfactory control over leakage is not attainable.

R.2.1 Stuffing box Removal



CAUTION! *Prior to removing the agitator drive, review the agitator installation to assure that all safety issues are resolved.*

1. Lock out and disconnect all power to the gear drive motor and optional devices.
2. Depressurize and ventilate vessel.
3. Remove stuffing box packing:

Remove hex adjusting nuts, lock washers, flat washers and gland clamps [1301, 1302, 1303, 1304]. Remove split packing gland [1312]. With packing tools (supplied by others), remove packing [1313].



CAUTION! *Never add new packing on top of the old packing, as this will cause accelerated wear and scoring of the shaft.*

Refer to the unit assembly drawing for the number and composition of the packing rings supplied originally with your agitator.

R.2.2 Stuffing box repacking

1. Install packing rings [1313]. Stagger each packing split 90°. Seat each packing ring as it is installed. Install split packing gland and gland clamps [1312, 1304]. Retain with hex adjusting nut, lockwasher and flatwasher [1301, 1302, 1303].
2. Tighten the hex adjusting nuts. Let the packing set for five to ten minutes so that it can cold flow and adjust to the gland pressure. Loosen the hex adjusting nuts, then finger tighten.

The stuffing box will require adjustment at start-up. Always strive for satisfactory sealing with the least gland force possible. Tighten the hex adjusting nuts uniformly and gradually (no more than one flat on the nuts every 15 minutes) until the leakage rate is acceptable. Do not over tighten. Make sure the split packing gland remains square with the shaft. Once the packing has been "run in", the hex adjusting nuts should be retightened on a regular basis. This can vary from weekly to monthly depending upon the desired level of sealing and the frequency of operation.

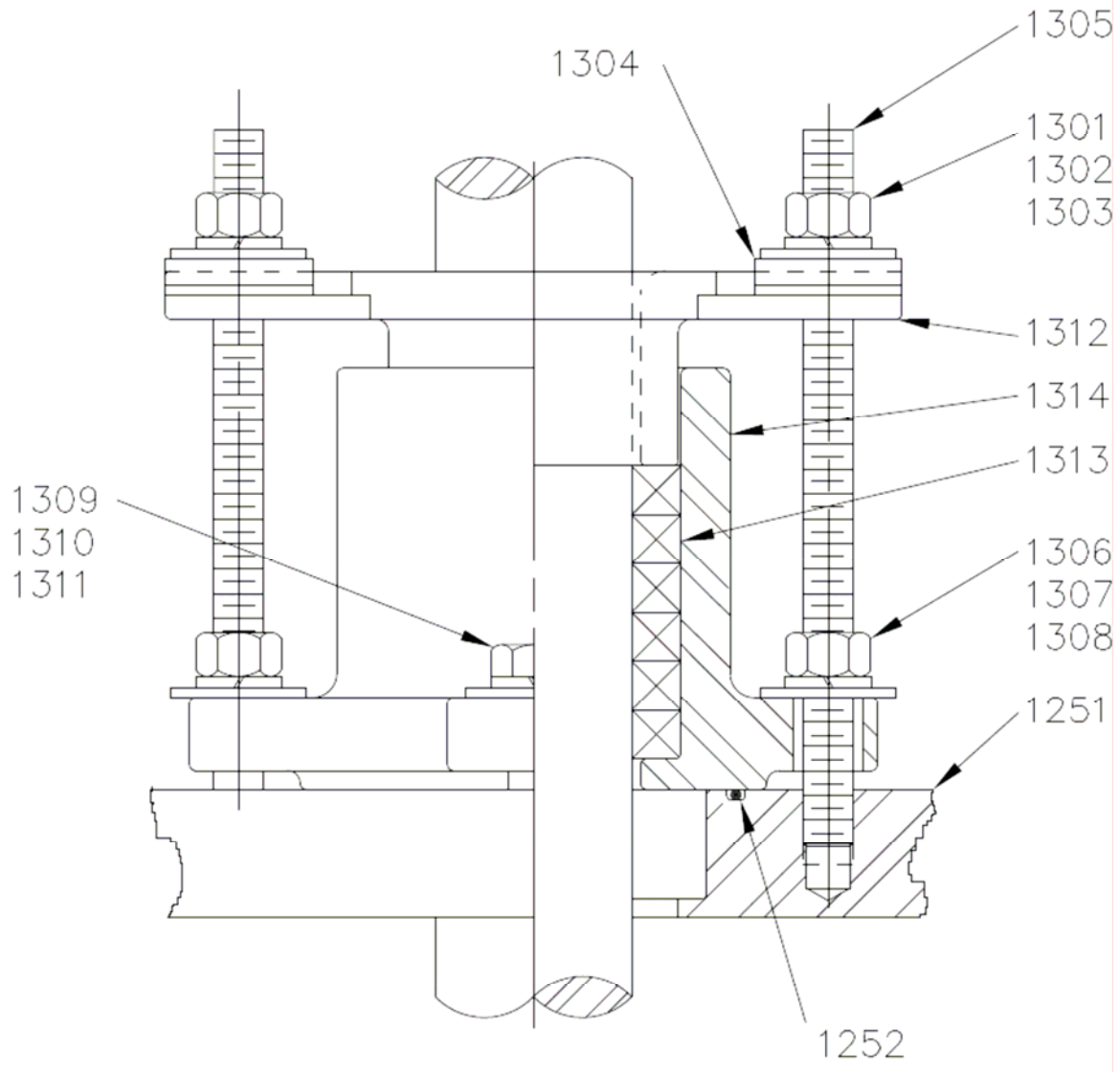

Figure 33. 6 – Ring Stuffing Box (cast housing)

R.3 MAINTENANCE – BOLT-ON STUFFING BOX (FABRICATED HOUSING)

The stuffing box is furnished with self-lubricating packing. It does not require any additional lubrication for the life of the packing. Routine maintenance consists of periodic inspections for leakage and tightening of hex adjusting nuts [1301]. Repacking is required when satisfactory control over leakage is not attainable.

R.3.1 Stuffing box Removal



CAUTION! *Prior to removing the agitator drive, review the agitator installation to assure that all safety issues are resolved.*

1. Lock out and disconnect all power to the gear drive motor and optional devices.
2. Depressurize and ventilate vessel.
3. Remove stuffing box packing:

Remove hex adjusting nuts [1301] and flat washers [1303]. Slide gland plate [1355] toward the gear drive. Remove split gland [1356]. With packing tools (supplied by others), remove packing [1313].



CAUTION! *Never add new packing on top of the old packing, as this will cause accelerated wear and scoring of the shaft.*

Refer to the unit assembly drawing for the number and composition of the packing rings supplied originally with your agitator.

R.3.2 Stuffing box repacking

1. Install packing rings [1313]. Stagger each packing split 90°. Seat each packing ring as it is installed. Install split gland [1356] (holes at top) and gland plate [1355]. Retain with hex adjusting nut and flatwasher [1301, 1303].
2. Tighten the hex adjusting nuts. Let the packing set for five to ten minutes so that it can cold flow and adjust to the gland pressure. Loosen the hex adjusting nuts, then finger tighten.

The stuffing box will require adjustment at start-up. Always strive for satisfactory sealing with the least gland force possible. Tighten the hex adjusting nuts uniformly and gradually (no more than one flat on the nuts every 15 minutes) until the leakage rate is acceptable. Do not over tighten. Make sure the split packing gland remains square with the shaft. Once the packing has been "run in", the hex adjusting nuts should be retightened on a regular basis. This can vary from weekly to monthly depending upon the desired level of sealing and the frequency of operation.

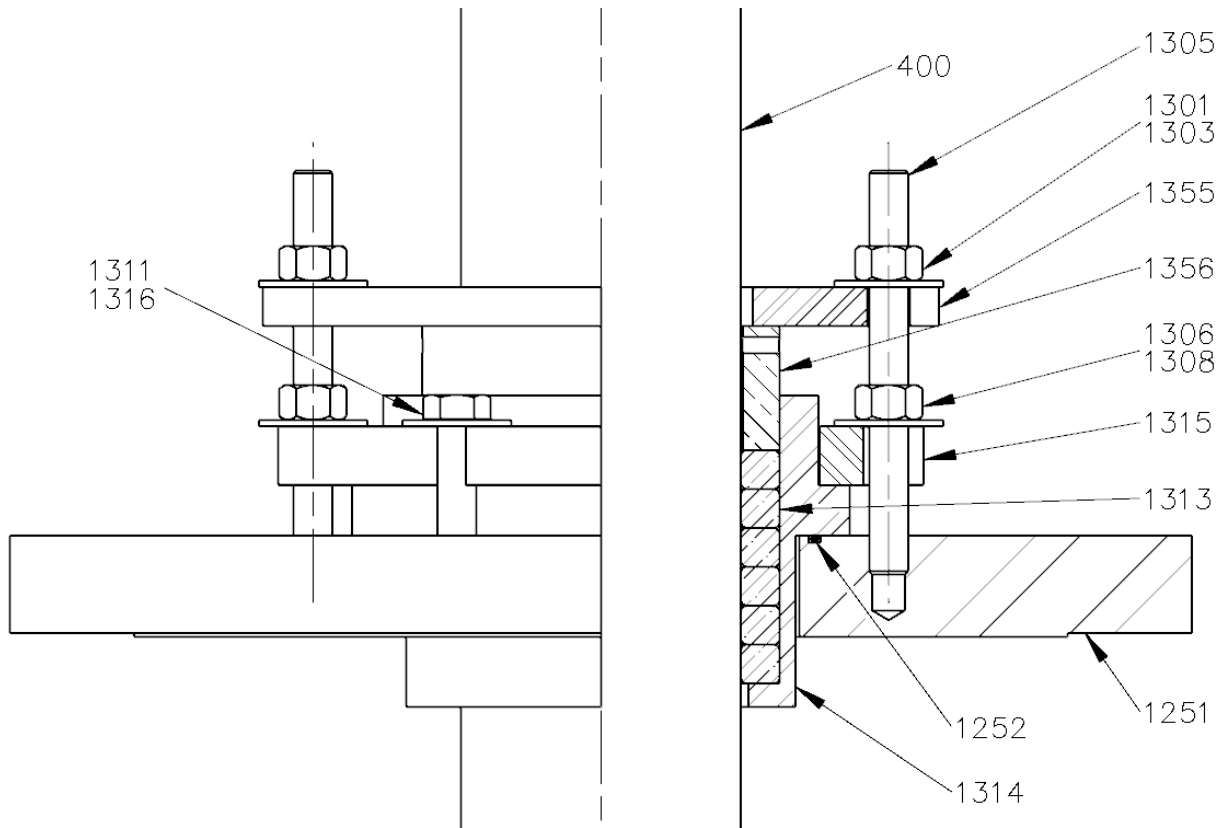

Figure 33B. 6 – Ring Stuffing Box (fabricated housing)

R.4 MAINTENANCE – AUXILIARY LIP SEAL

The lip seal, like any rotary shaft seal, will eventually wear and require replacement. Routine maintenance consists of periodic inspections for leakage. Replacement is required when a satisfactory shaft seal is no longer attainable.

R.4.1 Lip seal removal

1. Lock out and disconnect all power to the gear drive motor and optional devices.
2. Depressurize and ventilate vessel.
3. Remove handhole covers.
4. Remove snap ring [1852] and lip seal [1853] from flange [1851].
5. Lip seal will need to be cut for removal from shaft. Snap Ring Can remain on the shaft until the new lip seal has been installed.

R.4.2 Lip seal replacement

1. Place the new pre-split lip seal into the flange.
2. Reinstall the snap ring [1852] into flange [1851].
3. Auxiliary lip seals do not require any adjustment or lubrication.

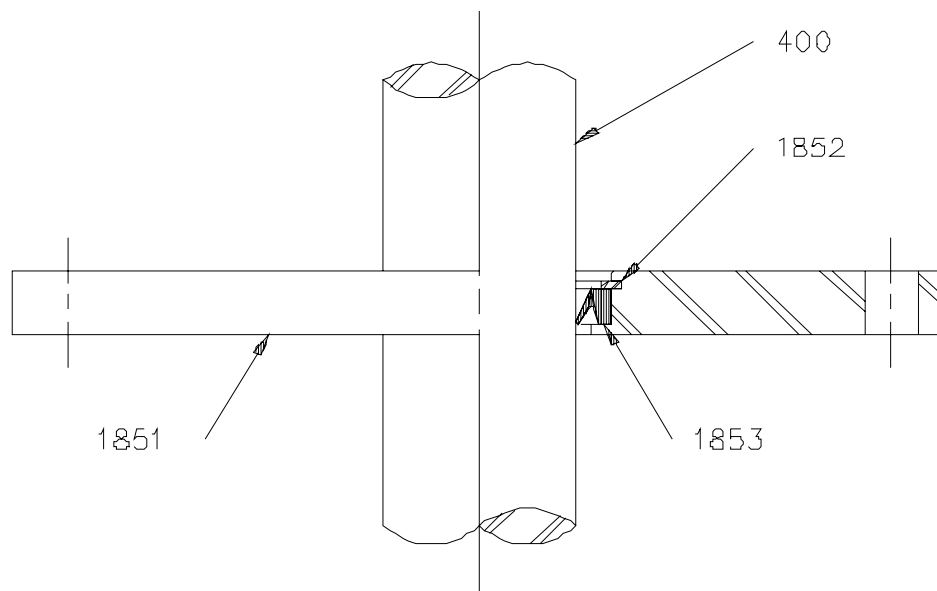

Figure 33B. Auxiliary Lip Seal

R.5 GEAR DRIVE

R.5.1 GTP/HTP Agitator drive removal

1. Lock out and disconnect all power to the gear drive motor and optional devices.
2. Depressurize and ventilate vessel.
3. Remove handhole covers.
4. Remove mounting bolts, lockwashers, and nuts [1102, 1103, 1104]. With a hoist or crane system, lift the agitator drive assembly (Figure 11, page 31) above the pedestal [1101] sufficiently to allow the shaft to be blocked in place. Remove coupling half bolts [360]. Refer to Figure 10, page 30.
5. Remove the agitator drive to a suitable service area

R.5.2 GTD/HTD Agitator drive removal

1. Lock out and disconnect all power to the gear drive motor and optional devices.
2. Depressurize and ventilate vessel.
3. Remove mounting bolts, lockwashers, and nuts (supplied by others). With a hoist or crane system, lift the agitator drive assembly (Section J, page 31) above the mounting structure sufficiently to allow the shaft to be blocked in place. Remove coupling half bolts [360]. Refer to Figure 10, page 30.
4. Remove the agitator drive to a suitable service area

R.5.3 Preparation for disassembly

1. Clean external surfaces and drain the oil.
2. Remove motor adapter mounting bolts [133]. Remove motor [100] and the motor adapter [131].
3. Refer to the *Gear drive Maintenance Manual* supplied with your agitator for gear drive disassembly and assembly instructions.

R.6 MAINTENANCE - STEADY BEARING

R.6.1 BRACKET, TRIPOD AND PAD STEADY BEARINGS

In-tank steady bearings will require periodic inspection and replacement of bushing and wear sleeve [606, 604] (Figure 26 on page 53, Figure 27A on page 58, or Figure 27B on page 60).

It is recommended that the steady bearing fasteners be checked for tightness and the bushing and wear sleeve for wear after the first two weeks of operation.

Unless otherwise specified the recommended wear allowance is:

Table 15. BRACKET, TRIPOD AND PAD STEADY BEARING WEAR SLEEVE AND BUSHING WEAR ALLOWANCES

SHAFT DIAMETER	UP TO 3" (76.2mm)	LARGER THAN 3" (76.2mm)
WEAR SLEEVE	.040" (1mm)	.060" (1.5 mm)
BUSHING	.120" (3mm)	.180" (4.5 mm)

The wear sleeve and bushing should be replaced in sets.



CAUTION! Lock out and disconnect all power to the gear drive motor, any optional devices, and depressurize vessel before servicing this equipment.

1. Loosen setscrew [605] and slide wear sleeve [604] off the shaft.
2. Unbolt the housing from the bracket or tripod (Not applicable to pad style).
3. Remove bushing retaining bolt and lockwasher [607, 608]. Remove the bushing from the steady bearing housing.
4. Press a new bushing into the steady bearing housing. Install the bushing retaining bolt and lockwasher.

NOTE: Line up the clearance hole in the new bushing with the tapped hole in the housing prior to pressing the bushing into the housing.

5. Reinstall the wear sleeve and housing/bushing assembly. Torque all fasteners to the value shown in APPENDIX, Page 100.



CAUTION! Do not operate the agitator without the steady bearing being submerged.

R.6.2 CUP TRIPOD STEADY BEARING

In-tank steady bearings will require periodic inspection and replacement of bushing and stub shaft [606, 630]. (Figure 27, page 55)

It is recommended that the steady bearing fasteners be checked for tightness and the bushing & stub shaft for wear after the first two weeks of operation.

Unless otherwise specified, the recommended wear allowance is:

Table 16. CUP TRIPOD STEADY BEARING WEAR SLEEVE AND BUSHING WEAR ALLOWANCES

SHAFT DIAMETER	UP TO 3" (76.2mm)	LARGER THAN 3" (76.2mm)
WEAR SLEEVE	.040" (1mm)	.060" (1.5 mm)
BUSHING	.120" (3mm)	.180" (4.5 mm)

The stub shaft and bushing should be replaced in sets.



CAUTION! Lock out and disconnect all power to the gear drive motor, any optional devices, and depressurize vessel before servicing this equipment.

1. Remove the retainer plate [631] and the stub shaft [630] from the stub shaft housing [634]. Remove the retainer to housing bolts and install them into the threaded holes on the retainer plate. Progressively tighten these bolts around the bolt circle to remove the stub shaft.



CAUTION! Tapers can disengage with a great deal of force; also the stub shaft/retainer assembly can be very heavy on larger size agitators. In order to hold the stub shaft when it disengages use half of the supplied retainer plate bolts threaded into the stub shaft housing.

2. Unbolt the bushing housing [627] from the coupling [620]. Remove the bushing retaining bolt [628] and lockwasher [629]. Press the bushing [606] out of the bushing housing [627].
3. Press a new bushing into the bushing housing. Install the bushing retaining bolt and lockwasher.

NOTE: Line up the clearance hole in the new bushing with the tapped hole in the bushing housing prior to pressing the bushing in place.

4. Reinstall the bushing housing, new stub shaft, and retainer plate as described in the *Steady bearings installation section* O.2. Torque fasteners to the value shown in Table 17, page 100.
5. Re-attach the flush piping.

S. ITEMS LIST

Item#	Description	Qty.
100	Motor	1
101	motor key	1
110	flexible motor coupling assembly	1
120	Gear drive cover plate assembly	1
121	cover plate	1
122	bolt	4
130	Motor adapter assembly	1
131	motor adapter	1
132	alignment pin	2
133	bolt	4
135	bolt	4
136	lockwasher	4
137	socket head bolt (HT Only)	1
138	spacer (HT Only)	1
139	bushings (HT Only)	2
200	Gear drive	1
202	input shaft	1
203	bearing (taper roller)	1
204	lip seal	1
212	v-ring seal	1
217	bearing (cylindrical roller)	1
233	bearing (taper roller)	1
244	output shaft	1
245	bearing (taper roller)	1
249	lip seal	1
254	bearing cap	1
258	dipstick/breather	1
260	grease fitting	1
261	relief fitting	1
262	grease fitting	1
263	plug, NPT	1
264	magnetic drain plug, NPT	1

Item#	Description	Qty.
266	set screw plug, NPT	1
267	pipe plug, NPT	1
269	input shaft key	1
350	Low Speed Coupling Assembly	1
351	gear drive coupling half	1
352	key	1
353	coupling washer (1 bolt)	1
354	coupling washer (2 bolt)	1
355	lockwasher	1
356	bolt	1
357	lockwasher	2
358	bolt	2
361	bolt	
	HT models ONLY	
370	Spiral bevel cartridge assembly	1
384	grease fitting	1
385	grease fitting	1

Note: For detail list of gear drive items please refer to appropriate gear drive IOM manual

Item#	Description	Qty.
400	Extension shaft assembly	1
402	pin key	1
403-001	drive shaft (welded coupling)	1
403-002	drive shaft (removable coupling)	1
404-001	extension shaft (welded coupling)	1
404-002	extension shaft (removable coupling)	1
405	bolt	
406	lockwasher	
407	nut	
408	rigid, removable, taper bore coupling half	1
409	key	1
410	coupling washer	1
412	locking clip	1
413	rigid, removable, taper bore coupling half	1
414	key	1
415	coupling washer	1
416	locking clip	1
418	shaft bolt	1
419	shaft bolt	1
420	key	1
421	coupling washer	1
422	bolt	2
423	lockwasher	2
424	coupling washer	1
425	bolt	2
426	lockwasher	2

Item#	Description	Qty.
500	Impeller assembly	
501	impeller assembly P-4	
502	impeller assembly S-4	
503	impeller assembly HE-3	
504	hub	
505	setscrew	
506	extension blade	
507	bolt	
508	lockwasher	
509	nut	
510	stabilizer fin	
511	bolt	
512	lockwasher	
513	nut	
514	impeller assembly D-6, CD-6, BT-6	
515	split disc	
516	bolt	
517	flatwasher	
518	bolt	
519	flatwasher	
520	locking clip	
521	nut	
522	gasket	2
523	snap ring	1
524	thrust plate	1
525	gasket	1
526	mounting bolt	1
527	impeller assembly SC-3	
528	impeller assembly Maxflo W	
529	bolt	
530	lockwasher	
531	nut	
532	impeller assembly XE-3	

Item#	Description	Qty.
600	Steady bearing assembly	1
601	bracket steady bearing	1
602	pad steady bearing	1
603-001	cup tripod steady bearing	1
603-002	tripod steady bearing	1
604	wear sleeve	1
605	setscrew, square head	
606	bushing	1
607	bushing retaining bolt	1
608	lockwasher	1
609	steady bearing housing	1
610	drain plug, NPT	1
620	coupling	1
621	coupling bolt	4 to 6
622	lockwasher	4 to 6
623	key	1
624	coupling washer	1
625	shaft bolt	2
626	lockwasher	2
627	bushing housing	1
628	bushing retaining bolt	1
629	lockwasher	1
630	stub shaft	1
631	retainer plate	1
632	retainer plate bolt	4 to 8
633	lockwasher	4 to 8
634	stub shaft housing	1
635	leg	3
636	leg bolt	6
637	leg nut	6
638	lockwasher	6
639	flat washer	6
640	alignment pin	3
641	pipe plug (flush)	1

Item#	Description	Qty.
700	Mounting plates	1
701	plate	4
702	bolt	4
703	lockwasher	1
704	bolt	8
705	lockwasher	8
706	plate	1
900	Anchor bolt assembly	1
901	anchor bolt	4
902	nut	4
903	lockwasher	4
904	flatwasher	4
1100	Pedestal assembly	1
1101	pedestal	1
	<i>For case size 21 and 22 only</i>	
1102	Bolt	4
1103	Lockwasher	4
1104	nut	4
1105	handhole cover	4
1106	Bolt	4
1107	Lockwasher	4
1108	Flatwasher	4
1109	Lockwasher	4
1110	Nut	4
	<i>For case size 23 only</i>	
1130	nut	3
1135	handhole cover	4
1136	bolt	3
1137	lockwasher	3
1138	flatwasher	3
1139	lockwasher	3
1141	bolt	1
1142	lockwasher	1
1143	flatwasher	1

Item#	Description	Qty.
1250	Mounting flange assembly	1
1251	mounting flange	1
1252	o-ring	1
1300	Auxiliary stuffing box assembly (bolt-in)	1
1301	hex adjusting nut	2
1302	lockwasher	2
1303	flatwasher	2
1304	gland clamps	2
1305	stud	2
1306	nut	2
1307	lockwasher	2
1308	flatwasher	2
1309	bolt	2
1310	lockwasher	2
1311	flatwasher	2
1312	split packing gland	2
1313	packing	6
1314	packing housing	1
1315	clamping gland	1
1316	bolt	4
1350	Auxiliary stuffing box assembly (integral)	1
1351	flanged stuffing box (6 ring)	1
1352	stud	2
1353	gland nut	2
1354	lockwasher	2
1355	gland plate	1
1356	split gland	1
1357	packing (2 sets of 3 rings)	6
1358	lantern ring	1
1359	grease fitting	1
1360	pipe plug, NPT	1
1850	Auxiliary lip seal assembly	1
1851	lip seal flange	1
1852	Snap ring	1
1853	lip seal	1

T. APPENDIX I

Tighten all fasteners to values shown unless specifically instructed to do otherwise. Lubricate all fasteners at assembly with thread lubricant or an anti-seize material. Bolt threads and contact surfaces of bolt heads and nuts should be lubricated. Note that stainless steel and alloy fasteners can gall while being tightened. The risk of galling or thread seizing is reduced by using lubrication, by tightening fasteners with low rpm's and without interruptions, and applying only light pressure. Dry fasteners, components with dirt or dust, bolting faces with rough finish, or even some environmental factors such as heat or moisture can effect the torque readings, and require values different than those listed in the table below.

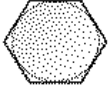
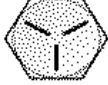
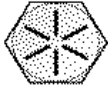
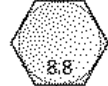

Table 17. BOLT TIGHTENING TORQUE

BOLT SIZE	SAE J429 CARBON STEEL						STAINLESS STEEL	
	GRADE 2 METRIC GRADE 4.6		GRADE 5 METRIC GRADE 8.8		METRIC GRADE 12.9		300 Series Stainless Steel (e.g. 304, 316)	
	ft-lb	Nm	ft-lb	Nm	ft-lb	Nm	ft-lb	Nm
1/4 - 20	-	-	6	8.1	-	-	4.1	5.6
5/16 - 18	-	-	13	18	-	-	8	11
3/8 - 16	-	-	23	31	-	-	15	20
1/2 - 13	38.0	52	55	75	-	-	38	52
9/16 - 12	50.0	68	79	107	-	-	50	68
5/8 - 11	68.0	92	110	149	-	-	68	92
3/4 - 10	120.0	163	195	264	-	-	95	129
7/8 - 9	122.0	165	314	426	-	-	153	207
1 - 8	184.0	250	470	637	-	-	230	312
1-1/8 - 7	260.0	353	587	796	-	-	326	442
1-1/4 - 7	368.0	499	828	1123	-	-	460	624
1-3/8 - 6	482.0	654	1085	1471	-	-	602	816
1-1/2 - 6	640.0	868	1440	1953	-	-	800	1085
M6 x 1.00	3.8	5.1	6.9	9.4	9.7	13	4.3	5.8
M8 x 1.25	8	10	17	23	24	32	10	14
M10 x 1.50	15	20	34	45	47	63	21	28
M12 x 1.75	26	35	58	79	81	110	36	49
M16 x 2.00	64	87	145	196	202	274	89	121
M20 x 2.50	126	170	282	383	394	534	174	236
M24 x 3.00	217	295	489	663	537	728	300	407

Table 18. BOLT TIGHTENING TORQUE (CONTD)

BOLT SIZE	ALLOY 600 (UNS#N06600), ALLOY C4 (UNS#N06455), ALLOY G30 (UNS#N06030), ALLOY 2205 (UNS#S32205)		ALLOY C276 (UNS#N10276), ALLOY C2000 (UNS#N06200)		ALLOY 20 (UNS#N08020), ALLOY 400 (UNS#N04400), ALLOY 825 (UNS#N08825)	
	ft-lb	Nm	ft-lb	Nm	ft-lb	Nm
1/4 - 20	4	5.4	5	6.8	3.4	4.6
5/16 - 18	8	11	10	14	7	9
3/8 - 16	15	20	18	25	12	17
1/2 - 13	36	49	45	61	30	41
9/16 - 12	52	70	65	88	43	59
5/8 - 11	72	97	89	121	60	81
3/4 - 10	127	172	159	215	106	143
7/8 - 9	205	277	256	347	170	231
1 - 8	307	416	383	520	256	346
1-1/8 - 7	435	589	543	737	362	491
1-1/4 - 7	613	832	767	1040	511	693
1-3/8 - 6	804	1090	1005	1363	670	908
1-1/2 - 6	1067	1447	1334	1809	889	1206
M6 x 1.00	3.7	5.0	4.9	6.6	3.1	4.2
M8 x 1.25	9	12	12	16	7	10
M10 x 1.50	18	24	24	32	15	20
M12 x 1.75	31	42	41	56	26	35
M16 x 2.00	77	104	102	139	64	87
M20 x 2.50	150	203	200	271	125	169
M24 x 3.00	276	374	345	468	216	292

Table 19. Bolt grades and mechanical properties

Head Marking	Grade and Material	Nominal Size Range (inches)	Mechanical Properties		
			Proof Load (psi)	Min. Yield Strength (psi)	Min. Tensile Strength (psi)
US Bolts					
 No Markings	Grade 2 Low or medium carbon steel	1/4 thru 3/4	55,000	57,000	74,000
		Over 3/4 thru 1-1/2	33,000	36,000	60,000
 3 Radial Lines	Grade 5 Medium Carbon Steel, Quenched and Tempered	1/4 thru 1	85,000	92,000	120,000
		Over 1 thru 1-1/2	74,000	81,000	105,000
 6 Radial Lines	Grade 8 Medium Carbon Alloy Steel, Quenched and Tempered	1/4 thru 1-1/2	120,000	130,000	150,000
Stainless markings vary. Most stainless is non-magnetic	18-8 Stainless Steel alloy with 17-19% Chromium and 8-13% Nickel	1/4 thru 5/8		40,000 Min. 80,000 – 90,000 Typical	100,000 – 125,000 Typical
		3/4 thru 1		40,000 Min. 45,000 – 70,000 Typical	100,000 Typical
		Above 1			80,000 – 90,000 Typical
Head Marking	Class and Material	Nominal Size Range (mm)	Mechanical Properties		
			Proof Load (MPa)	Min. Yield Strength (MPa)	Min. Tensile Strength (MPa)
Metric bolts					
 8.8	Class 8.8 Medium Carbon Steel, Quenched and Tempered	All Sizes below 16mm	580	640	800
		16mm - 72mm	600	660	830
 10.9	Class 10.9 Alloy Steel, Quenched and Tempered	5mm - 100mm	830	940	1040
12.9	Class 12.9 Alloy Steel, Quenched and Tempered	1.6mm - 100mm	970	1100	1220
Stainless markings vary. Most stainless is non-magnetic. Usually stamped A-2	A-2 Stainless Steel alloy with 17- 19% Chromium and 8-13% Nickel	All Sizes thru 20mm		210 Min. 450 Typical	500 Min. 700 Typical
Tensile Strength: The maximum load in tension (pulling apart) which a material can withstand before breaking or fracturing.					
Yield Strength: The maximum load at which a material exhibits a specific permanent deformation					
Proof Load: An axial tensile load which the product must withstand without evidence of any permanent set.					
1MPa = 1N/mm ² = 0.2248 pounds/mm ²					

(Source: www.boltdepot.com)



P.O. Box 1123
Dayton, Ohio 45401
Phone: (937) 454-3200
Fax: (937) 454-3379

<http://www.chemineer.com>