

24K Coiled Tubing Reel



Built on tradition and dependability

Our 24K tubing reel is a small-capacity tubing reel optimized to be skid or trailer mounted. It provides an upgraded option to current reels, resulting in greater efficiencies on location and back at the yard. This design is ideally suited for all grades of 1½- to 2-in. coiled tubing.

Powering the reel is a patented and purposefully built direct-drive gear box, providing confidence in the field for all applications, including coiled tubing and wireline operations. Wireline options that previously required a chain drive can now be handled with the performance and reliability of this direct drive.

We have incorporated the optional levelwind quick-change ratio cartridges, keeping efficiency in mind.

Features and benefits

- Decreased flange flex due to high-strength, double-tapered spoke design
- Accommodates strings with 110,000-lb operational payload
- Direct-drive gear box eliminates the potential for a drive-chain failure and loss of control of the reel
- Patented hybrid planetary offsets motor and allows for a collector port for wireline on drive side and optionally allows for remote hydraulic operation of spool safety valve
- Optional levelwind quick-change ratio cartridges allow easy levelwind ratio timing when swapping sizes

24K Coiled Tubing Reel

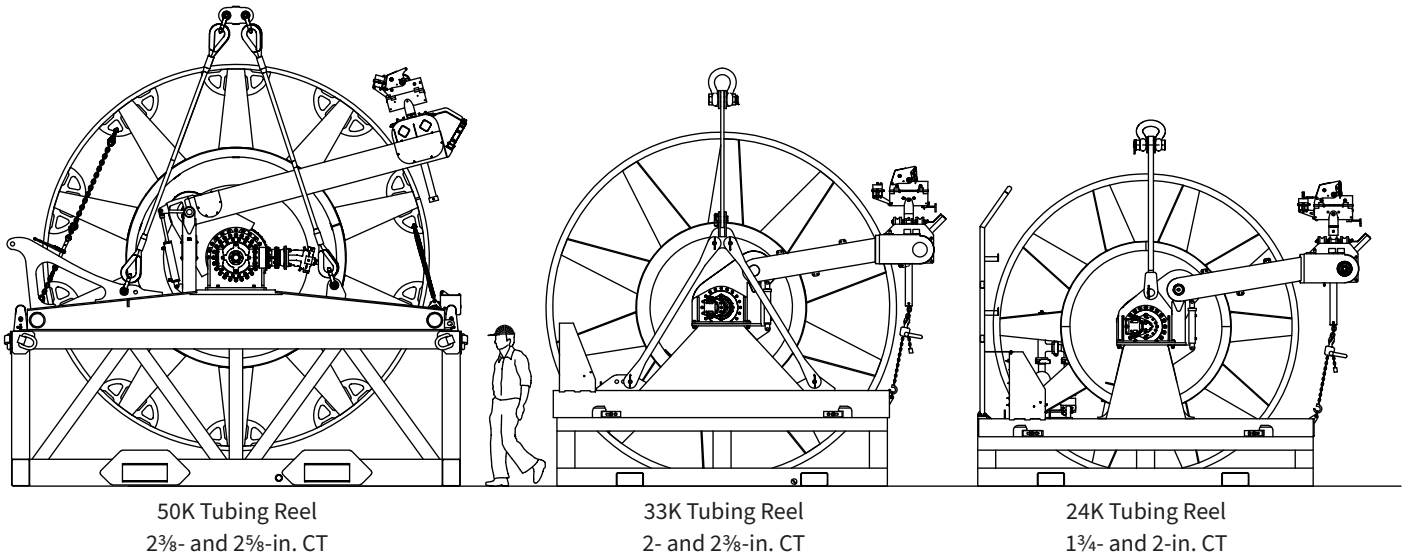

Our tubing reel product line consists of reels sized to meet different applications, tubing sizes, and capacities. The 50K is currently the largest, suited for long strings, large units, and milling. The 33K and 24K are sized for medium and small strings where transportation limits are more restrictive. Contact your NOV sales representative to determine the right reel for your operation's needs.

**24K Tubing Reel Drive Performance
for 1 3/4- and 2-in. Tubing**

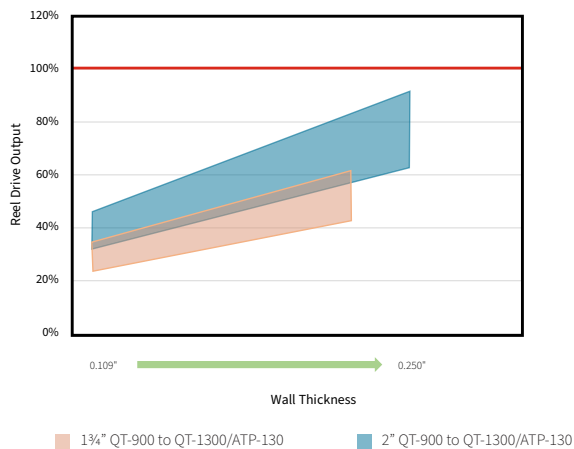

Specifications

Reel dimensions*	144-in. OD, 72-in. core, 69-in. width
Maximum coiled tubing OD	2 in.
Reel capacity (based on 8 1/2 ft wide CTU)*	21,400 ft of 1 3/4-in. coiled tubing
Hydraulic drive	2,500 psi
Operational payload**	110,000 lb
Transportation payload***	Dependant on size of reel (width)

*24K tubing reels are available in various sizes to fit different coiled tubing designs and local transportation needs.

**Maximum weight of tubing, fluid, and cable during stationary operations on the wellsite (may be reduced by trailer limitations)

***Maximum weight of tubing, fluid, and cable during transport

Based on design projections, factors that will affect the reel drive performance include:

- CTU hydraulic system capability and condition
- Drive system condition
- Actual string design and material yield strength
- Rig up: Height and distance between the tubing reel and the injector
- Required tubing tension: Using the minimal amount of reel tension required to maintain proper tubing wrapping on the reel is suggested.