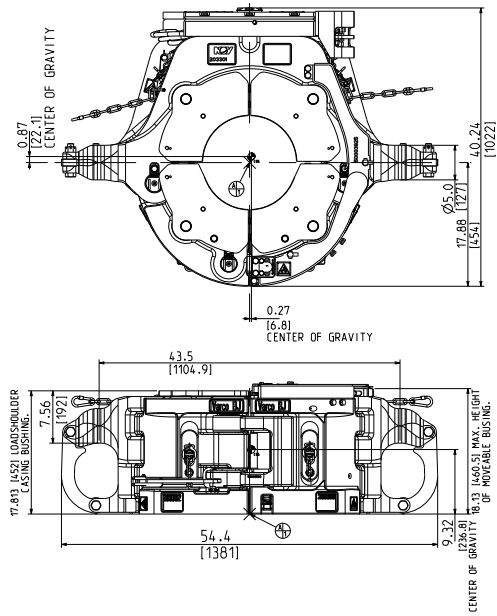

BX3™

The BX 3, 4, and 5 elevators improve both rig safety and efficiency. Since the introduction of the BX 1 and 2 elevators in 1996, our engineers have continuously strived to improve the operations reliability and safety of its design, resulting in the present BX 3, 4, and 5 design.

- One door bushing is spring loaded with linkage connecting it to a lockin pin
- Rotator for easier handling
- Hydraulically actuated elevator
- Hydraulic cylinders
- Quick and easy change of changeable bushings
- Trigger mechanism

Technical specifications

Actuation	Hydraulic
Control system	Automatic remote controlled (stand-alone control panel or driller)
Dimension LxWxH	40.24" x 54.40" x 18.06"
Weight	2,445 lbs
Tubular types	Casing, drill collar (plain)
Tubular size range (slips)	9 5/8" to 20"
Changing slips	Manually
Load rating	Up to 350 sTon
Power down force	N/A
Req. pressure	2,000 - 2,500 psi (hydraulic)
Flow rate	5 to 7 gpm
Ambient temp. range	-4°F up to 131°F (-20°C up to +55°C)
Req. crew to operate	1
Manpower interfering	No
Interlocking	Yes
Greasing	Hand
BX-closed signal confirmation	Yes
Link size	2 1/4", 3 1/2"
Use of rotator	Yes
API	8C
CE	Yes
ATEX	Yes

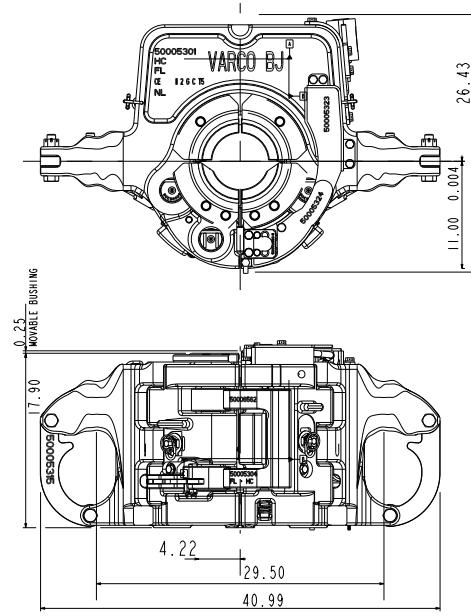
BX4-35™

The BX 3, 4, and 5 elevators improve both rig safety and efficiency. Since the introduction of the BX 1 and 2 elevators in 1996, our engineers have continuously strived to improve the operations reliability and safety of its design, resulting in the present BX 3, 4, and 5 design.

- Rotator for easier handling
- Hydraulically actuated elevator
- Hydraulic cylinders
- Quick and easy change of changeable bushings
- Trigger mechanism

Technical specifications

Actuation	Hydraulic
Control system	Automatic remote controlled (stand-alone control panel or driller)
Dimension LxWxH	26.43" x 40.99" x 17.90"
Weight	1,600 lbs
Tubular types	Drill pipe, casing, drill collar (plain & zip lift), tubing, square shoulder, riser
Tubular size range (slips)	2 3/8" to 7 1/4"
Changing slips	Manually
Load rating	Up to 350 sTon
Power down force	N/A
Req. Pressure	2,000 - 2,500 psi (hydraulic)
Flow rate	5 to 7 gpm
Ambient temp. range	-4°F up to 131°F (-20°C up to +55°C)
Req. crew to operate	1
Manpower interfering	No
Interlocking	Yes
Greasing	Hand
BX-closed signal confirmation	Yes
Link size	2 1/4", 3 1/2"
Use of rotator	Yes
API	8C
CE	Yes
ATEX	Yes

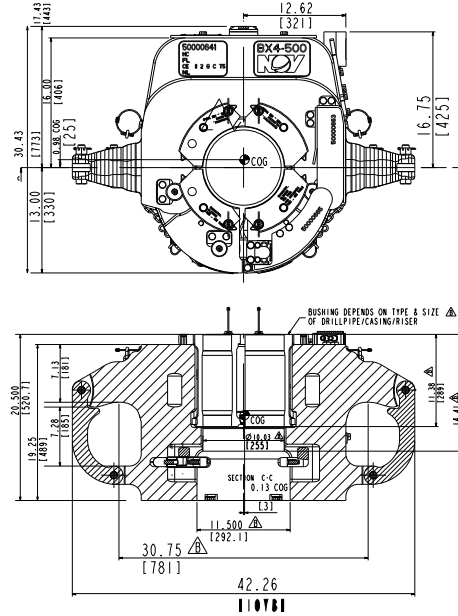
BX4-50™

The BX 3, 4, and 5 elevators improve both rig safety and efficiency. Since the introduction of the BX 1 and 2 elevators in 1996, our engineers have continuously strived to improve the operations reliability and safety of its design, resulting in the present BX 3, 4, and 5 design.

- One door bushing is spring loaded with linkage connecting it to a locking pin
- Rotator for easier handling
- Hydraulically actuated elevator
- Hydraulic cylinders
- Quick and easy change of changeable bushings
- Trigger mechanism

Technical specifications

Actuation	Hydraulic
Control system	Automatic remote controlled (stand-alone control panel or driller)
Dimension LxWxH	30.43" x 42.26" x 20.50"
Weight	2,278 lbs
Tubular types	Drill pipe, casing, drill collar (plain & zip lift), tubing, square shoulder, riser
Tubular size range (slips)	2 3/8" to 9 3/4"
Changing slips	Manually
Load rating	Up to 500 sTon
Power down force	N/A
Req. pressure	2,000 - 2,500 psi (hydraulic)
Flow rate	5 to 7 gpm
Ambient temp. range	-4°F up to 131°F (-20°C up to +55°C)
Req. crew to operate	1
Manpower interfering	No
Interlocking	Yes
Greasing	Hand
BX-closed signal confirmation	Yes
Link size	2 3/4", 4 3/4"
Use of rotator	Yes
API	8C
CE	Yes
ATEX	Yes

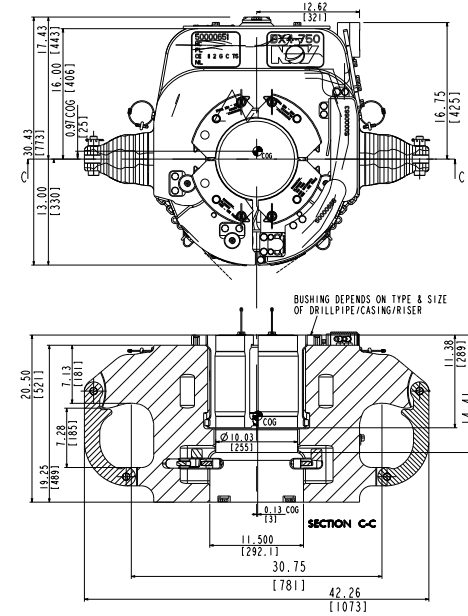
BX4-75™

The BX 3, 4, and 5 elevators improve both rig safety and efficiency. Since the introduction of the BX 1 and 2 elevators in 1996, our engineers have continuously strived to improve the operations reliability and safety of its design, resulting in the present BX 3, 4, and 5 design.

- One door bushing is spring loaded with linkage connecting it to a locking pin
- Rotator for easier handling
- Hydraulically actuated elevator
- Hydraulic cylinders
- Quick and easy change of changeable bushings
- Trigger mechanism

Technical specifications

Actuation	Hydraulic
Control system	Automatic remote controlled (stand-alone control panel or driller)
Dimension LxWxH	30.43" x 42.26" x 20.50"
Weight	2,292 lbs
Tubular types	Drill pipe, casing, drill collar (plain & zip lift), tubing, square shoulder, riser
Tubular size range (slips)	2 3/8" to 9 3/4"
Changing slips	Manually
Load rating	Up to 750 sTon
Power down force	N/A
Req. pressure	2,000 - 2,500 psi (hydraulic)
Flow rate	5 to 7 gpm
Ambient temp. range	-4°F up to 131°F (-20°C up to +55°C)
Req. crew to operate	1
Manpower interfering	No
Interlocking	Yes
Greasing	Hand
BX-closed signal confirmation	Yes
Link size	3 1/2", 4 3/4"
Use of rotator	Yes
API	8C
CE	Yes
ATEX	Yes

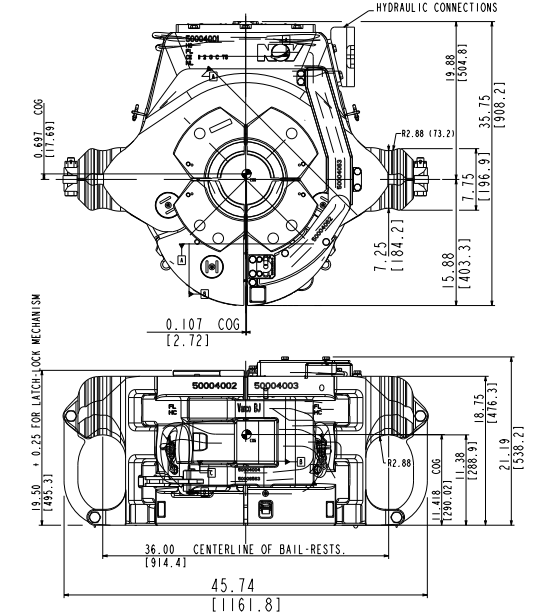
BX5™

The BX 3, 4, and 5 elevators improve both rig safety and efficiency. Since the introduction of the BX 1 and 2 elevators in 1996, our engineers have continuously strived to improve the operations reliability and safety of its design, resulting in the present BX 3, 4, and 5 design.

- One door bushing is spring loaded with linkage connecting it to a locking pin
- Rotator for easier handling
- Hydraulically actuated elevator
- Hydraulic cylinders
- Quick and easy change of changeable bushings
- Trigger mechanism

Technical specifications

Actuation	Hydraulic
Control system	Automatic remote controlled (stand-alone control panel or driller)
Dimension LxWxH	35.67" x 48.0" x 26.45"
Weight	3,586 lbs
Tubular types	Drill pipe, casing, drill collar (plain & zip lift), tubing, square shoulder, riser
Tubular size range (slips)	3 1/2" to 11"
Changing slips	Manually
Load rating	Up to 1,000 sTon
Power down force	N/A
Req. pressure	2,000 - 2,500 psi (hydraulic)
Flow rate	5 to 7 gpm
Ambient temp. range	-4°F up to 131°F (-20°C up to +55°C)
Req. crew to operate	1
Manpower interfering	No
Interlocking	Yes
Greasing	Hand
BX-closed signal confirmation	Yes
Link size	4 3/4", 5 1/2"
Use of rotator	Yes
API	8C
CE	Yes
ATEX	Yes

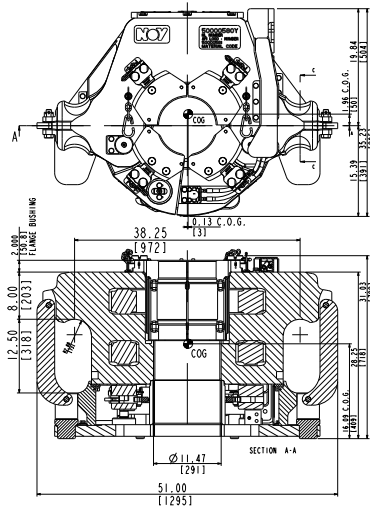
BX7™

Construction of deepwater and ultra-deepwater drilling rigs created demand for equipment with a greater capacity. The BX7 has a rating of 1,000 short tons for drill pipe and landing strings, and 1,250 short tons for riser handling and square shouldered couplings.

- Body, doors and latch of the elevator are forged to provide more homogeneous properties with increased impact so load resistance is obtained
- Double rotator for easier handling. Hydraulically actuated elevator
- Elevator provides a signal which can be used for interlocking
- BX7 operates with standard BX controls
- Changeable bushings
- Trigger mechanism

Technical specifications

Actuation	Hydraulic
Control system	Automatic remote controlled (stand-alone control panel or driller)
Dimension LxWxH	35.23" x 51.0" x 31.0"
Weight	4,951 lbs
Tubular types	Drill pipe, casing, drill collar (plain), tubing, square shoulder, riser
Tubular size range (slips)	4" to 9 5/8"
Changing slips	Manually
Load rating	Up to 1,250 sTon
Power down force	N/A
Req. pressure	2,000 - 2,500 psi (hydraulic)
Flow rate	5 to 7 gpm
Ambient temp. range	-4°F up to 131°F (-20°C up to +55°C)
Req. crew to operate	1
Manpower interfering	No
Interlocking	Yes
Greasing	Hand
BX-closed signal confirmation	Yes
Link size	5 1/2" (1,000 sTon), 5 1/2" (1,250 sTon)
Use of rotator	Yes (double)
API	8C
CE	Yes
ATEX	Yes

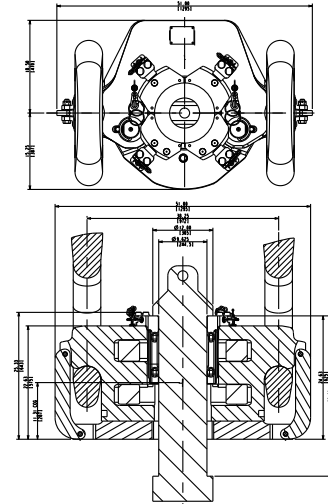
SBX™

Construction of deepwater and ultra-deepwater drilling rigs created demand for equipment with a greater capacity. The SBX is a manual operated single door solid body elevator. It has a rating of 1,250 short tons for riser handling with square shouldered couplings/45° tool joints.

- Body, doors and latch of the elevator are forged to provide more homogenous properties with increased impact so load resistance is obtained
- Double rotator for easier handling
- Changeable bushings

Technical specifications

Actuation	Manually
Control system	N/A
Dimension LxWxH	33.75" x 51.0" x 25.33"
Weight	4,575 lbs
Tubular types	Riser
Tubular size range (slips)	8" to 9 5/8"
Changing slips	Manually
Load rating	Up to 1,250 sTon
Power down force	N/A
Req. pressure	N/A
Flow rate	N/A
Ambient temp. range	-4°F up to 131°F (-20°C up to +55°C)
Req. crew to operate	1
Manpower interfering	No
Interlocking	No
Greasing	Hand
BX-closed signal confirmation	No
Link size	5 1/2" (1,000 sTon), 5 1/2" (1,250 sTon)
Use of rotator	Yes (double)
API	8C
CE	Yes
ATEX	Yes

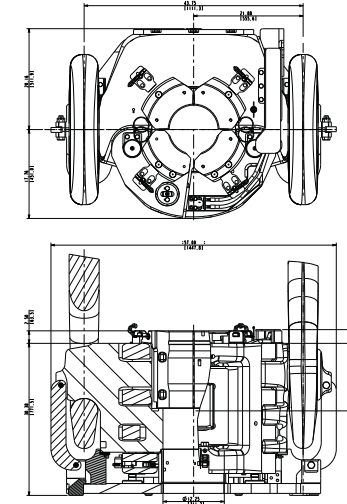
BX9™

Construction of deepwater and ultra-deepwater drilling rigs created demand for equipment with a greater capacity. The BX9 has a rating of 750-1,250 sTon for 18° shoulder, 750-1,500 sTon for 90° (square) shoulder and 1,250-1,500 sTon for riser handling and 45° shouldered couplings.

- Body, doors and latch of the elevator are forged to provide more homogeneous properties with increased impact so load resistance is obtained
- Double rotator for easier handling. Hydraulically actuated elevator
- Elevator provides a signal which can be used for interlocking
- BX9 operates with standard BX controls
- Changeable bushings
- Trigger mechanism

Technical specifications

Actuation	Hydraulic
Control system	Automatic remote controlled (stand-alone control panel or driller)
Dimension LxWxH	37.92" x 57.0" x 32.88"
Weight	6,605 lbs
Tubular types	Drill pipe, casing, 45° shoulder, landing string, square shoulder, riser
Tubular size range (slips)	5" to 10 3/4"
Changing slips	Manually
Load rating	Up to 1,500 sTon
Power down force	N/A
Req. pressure	2,000 - 2,500 psi (hydraulic)
Flow rate	5 to 7 gpm
Ambient temp. range	-4°F up to 131°F (-20°C up to +55°C)
Req. crew to operate	1
Manpower interfering	No
Interlocking	Yes
Greasing	Hand
BX-closed signal confirmation	Yes
Link size	5 3/4" (1,000/1,250 sTon), 6" (1,500 sTon)
Use of rotator	Yes
API	8C
CE	Yes
ATEX	Yes

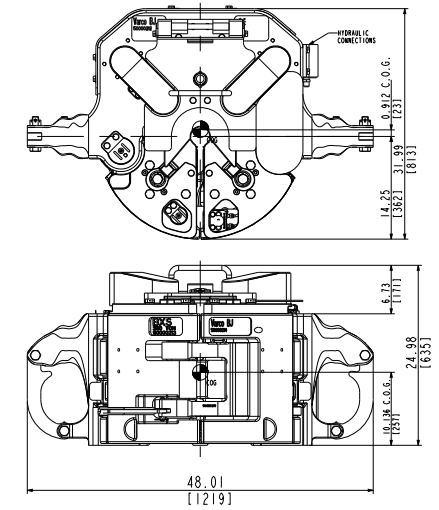
BXS™

The BXS allows a safe way to run a small upset and special clearance tubulars with the new BXS elevator. This tool enables rigs to handle flush or near flush tubulars without manual intervention. The BXS provides reliable operation and is suitable for use with the FMS 275 Flush Mounted Slip.

- Hydraulically powered, remote controlled elevator which supports hands-off operation
- BXS comes equipped with an automated "slip set" function, or the slip down function can be operator controlled when using the optional BX Hook-up kit
- Simplified hydraulic system provides reliable operation
- Redundant "slip set" signals provide positive feedback to the driller that the elevators are set on the pipe
- Internal springs are incorporated into the BX design for raising the slips, which result in minimal "power-up" force

Technical specifications

Actuation	Hydraulic
Control system	Automatic remote controlled (stand-alone control panel or driller)
Dimension LxWxH	31.99" x 48.01" x 24.98"
Weight	2,974 lbs
Tubular types	Pipe w/no to very small external upset or load shoulders
Tubular size range (slips)	2 3/8" to 7 5/8"
Changing slips	Manually
Load rating	350 sTon
Power down force	15,000 lbs
Req. pressure	2,000 - 2,500 psi (hydraulic)
Flow rate	5 to 7 gpm
Ambient temp. range	-4°F up to 131°F (-20°C up to +55°C)
Req. crew to operate	1
Manpower interfering	No
Interlocking	Yes
Greasing	Hand
BX-closed signal confirmation	Yes
Link size	2 1/4", 3 1/2"
Use of rotator	Yes
API	8C
CE	Yes
ATEX	Yes